

Design and Simulation of Single-Phase Three-Level, Four-Level and Five-Level Inverter Fed Asynchronous Motor Drive with Diode Clamped Topology

Gerald Diyike¹, Aniekan Offiong², Daniel Nnadi C³

¹ Department of Mechanical Engineering, Michael Okpara University of Agriculture, Umudike, P.M.B 7267, Abia State, Nigeria

² Department of Mechanical Engineering, University of Uyo, Uyo, P.M.B. 1017, Akwa Ibom State, Nigeria

³ Departments of Mechanical Engineering, Michael Okpara University of Agriculture, Umudike, P.M.B 7267, Abia State, Nigeria

ABSTRACT - This paper deals with study of single-phase three-level, four-level and five-level inverter fed asynchronous motor drive. Both three-level, four-level and five-level inverters are realized by diode clamped inverter topology. The poor quality of voltage and current of a convectional inverter fed asynchronous motor is due to presence of harmonic contents and hence there is significant level of energy losses. The multilevel inverter is used to reduce the harmonic contents. The inverter with a large number of steps can generate a high quality voltage waveform. The higher inverter levels can be modulated by comparing a sinusoidal reference signal and multiple triangular carrier signals by the means of pulse width modulation

technique. The simulation of single-phase three-level, four-level and five-level inverter fed asynchronous motor model is done using MATLAB/SIMULINK^R (The Math Works, Natick, Massachusetts, USA). The Fast Fourier Transform (FFT) spectrums of the outputs are analyzed to study the reduction in the harmonic contents.

Keywords - Asynchronous Motor, Multi-level inverters, pulse width modulation, Total harmonic distortion.

I. INTRODUCTION

Adjustable speed drives are the vital and endless demand of the industries and researchers. Asynchronous motors are widely used in the factories and industries to control the speed of conveyor systems, blower speeds, machine tool speeds and applications that require adjustable speed controls. Thus, single-phase asynchronous motors are extensively used for smaller loads, such as household appliances like fans, water pumps. In many industrial applications, traditionally, DC motors, provide excellent speed control for acceleration and deceleration with effective and simple torque control. The supply of a DC motor connects directly to the field of the motor allows for precise voltage control, which is necessary with speed and torque control applications. DC motors perform better than AC motors on the some traction equipment. They are also used for mobile equipment like golf cart, quarry and mining equipment. DC motors are conveniently portable and well suited to special applications, such as industrial tools and machinery that is not easily run from remote sources. But, they have inherent demerit of commutator and mechanical brushes, which undergo wear and tear with the passage of time. In most cases, AC motors are preferred to DC motors, in particular, an asynchronous motor due to its simple design, low cost, reliable operation, easily found replacements or low maintenance, variety of mounting styles, many environmental enclosures, lower weight, higher efficiency, improved ruggedness. All these and more features

make the use of induction motor compulsory in many areas of industrial applications. The main demerit of AC motor, when compared with DC motor, is that its speed is more difficult to control. AC motors can be equipped with variable frequency/PWM drives, which provide smooth turning moment, or torque, at low speeds and complete control over the speed of the motor up to its rated value. Variable frequency drives improves speed control, but do create losses with reduced power quality [1].

The advancement in Power Electronics and semiconductor technology has triggered the development of high power and high speed semiconductor devices in order to achieve a smooth, continuous and step less variation in motor speed. Applications of solid state converters/inverters for adjustable speed induction motor drive are wide spread in electromechanical systems for a large spectrum of industrial systems,[2],[3],[4]. As far as convectional two-level inverter is concerned, it exhibits many problems when used in high power application [5], [6]. Poor quality of output current and voltage of an asynchronous motor fed by a classical/ convectional two-level inverter configuration is due to the presence of harmonic content. The presence of significant amount of harmonic makes the motor to suffer from severe torque pulsations, especially at low speed, which manifest themselves in cogging of the shaft. It will also causes undesired motor heating and Electromagnetic interference [7]. Minimization in harmonics calls for large sized filter, resulting increased size and the cost of the system. The advancements in

the field of power electronics and microelectronics made it possible to reduce the magnitude of harmonics with multilevel inverters, in which the number of levels of the inverters are increased rather than increasing the size of the filters [8]. Nowadays, multilevel inverters have been gained more attention for high power application in recent years which operate at high switching frequencies while producing lower order harmonic components. Multilevel inverter not only achieves high power ratings, but also enables the use of renewable energy sources [9].

In this paper Single-phase three-level, four-level, and five-level inverter fed asynchronous motor drive are designed and simulated. Both the different levels are realized by using diode clamped multilevel inverter topology. The simulations are done using Matlab/Simulink/SimPowerSystems software with PWM control. The FFT spectrum for the output voltages and currents are analyzed to study the reduction in the harmonic contents.

II. MULTILEVEL INVERTER

Multilevel inverters have drawn tremendous interest in the power industry applications. They present a new set of features that are well suited for use in reactive power compensation. Multilevel inverters will most importantly reduce the magnitude of harmonics and increases the output voltage and power without the use of step-up transformer. Numerous multilevel inverters topologies have been proposed during the last decades. Modern research, have involved novel inverter topologies and unique modulation techniques [10]. Basically, three different major multilevel inverter topologies have been reported in the literature, which includes: diode clamped (neutral clamped) inverter, flying capacitors inverter, and cascaded H-bridge. Multilevel inverter presented in this paper consists of diode clamped inverter topology connected to single phase asynchronous motor. The general function of this multilevel inverter is to synthesize a desired voltage from several DC sources.

A. SINGLE-PHASE THREE-LEVEL, FOUR-LEVEL AND FIVE-LEVEL INVERTER CIRCUIT CONFIGURATIONS USING DIODE CLAMPED TOPOLOGY

The neutral point inverter proposed by Nabae, and Akagi in 1981 was essentially a three-level, diode-clamped inverter [10]. The diode-clamped inverter provides multiple voltage levels through connection of the phases to a series bank of capacitors [11]. The main concept of this type of multilevel inverter topology is to use diodes to limit the power devices voltage stress. The voltage over each capacitor and each switch is V_{dc} . A single-phase full bridge n -level inverter needs $(n - 1)$ voltage source, $4(n - 1)$ switching devices and $8(n - 1) - 4$ diodes. This topology can be extended to any number of levels by increasing the number of capacitor banks. Diode clamped multilevel inverter topology can be discussed under a single-

phase structures. Fig. 1 show single-phase three-level structure of Diode Clamped Inverter.

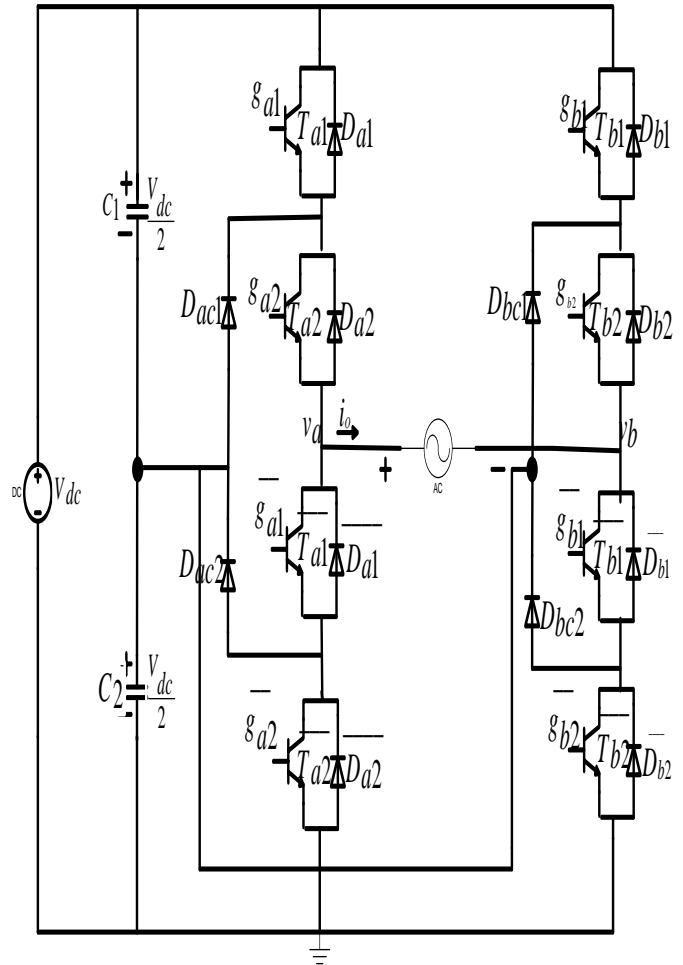

Fig. 1 Power circuit for Single-phase, three-level diode clamped inverter

As shown in the fig. 1 above, a single-phase full bridge three-level diode clamped inverter consists of two bulk capacitor (C_1 and C_2), four clamping diodes (D_{ac1} , D_{ac2} , D_{bc1} and D_{bc2}), eight antiparallel diodes (D_{a1} , D_{a2} , $\overline{D_{a1}}$, $\overline{D_{a2}}$, D_{b1} , D_{b2} , $\overline{D_{b1}}$, and $\overline{D_{b2}}$) and eight power switches (T_{a1} , T_{a2} , $\overline{T_{a1}}$, $\overline{T_{a2}}$, T_{b1} , T_{b2} , $\overline{T_{b1}}$, and $\overline{T_{b2}}$). For a given DC link voltage V_{dc} , the two capacitors C_1 and C_2 are connected in series across the DC link input. They split the DC link voltage across the capacitors with a constant value equals to $\frac{V_{dc}}{2}$. The clamping diodes D_{ac1} , D_{ac2} , D_{bc1} and D_{bc2} are used to maintain the potential across the switches. Thus, the voltage stress of each switch is limited to one capacitor voltage $\frac{V_{dc}}{2}$. For a single-phase three-level full bridge diode clamped inverter, the voltage across the output of the two legs can be equal to 0, $\frac{V_{dc}}{2}$ and V_{dc} . Fig. 2 shows a Single-phase four-level structure of Diode Clamped Inverter.

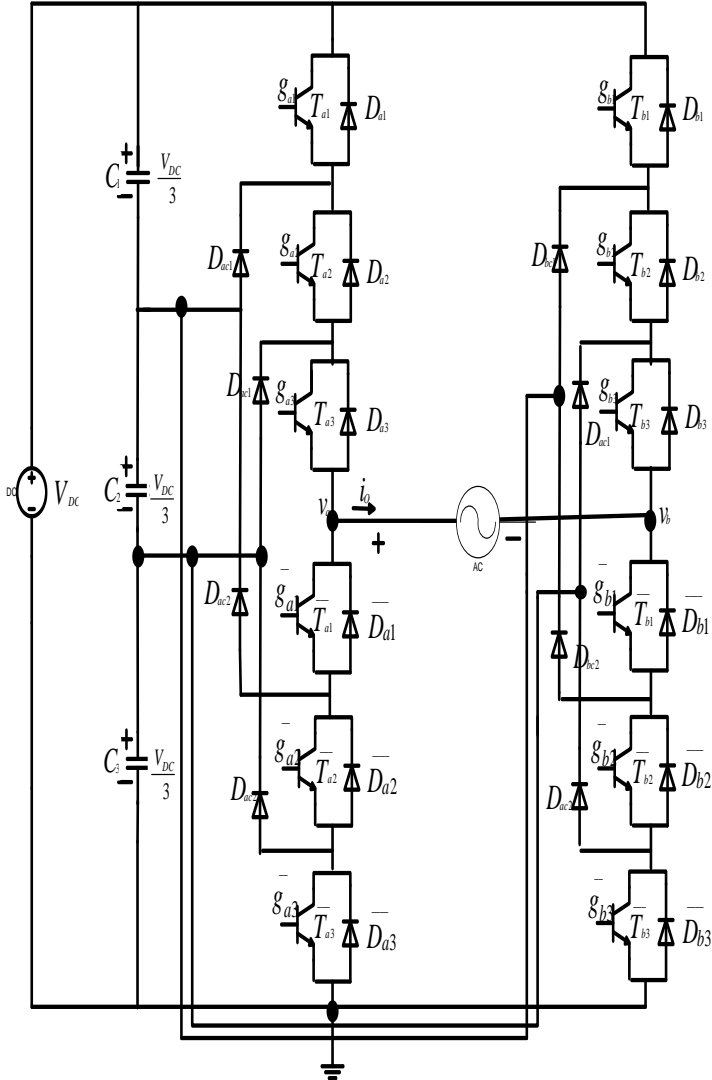

Fig. 2 Power circuit for Single-phase, four-level diode clamped inverter

The single-Phase Structure of diode clamped four-level inverter is illustrated in Fig. 2. DC voltage source is connected to the inverter circuit through three capacitors connected in series. They split the DC link voltage across the capacitors with a constant value equals to $\frac{V_{dc}}{3}$. Thus, the voltage stress of each switch is limited to one capacitor voltage $\frac{V_{dc}}{3}$. For a single-phase four-level full bridge diode clamped inverter, the voltage across the output of the two legs can be equal to 0, $\frac{V_{dc}}{2}$, $\frac{2V_{dc}}{3}$ and V_{dc} . Fig. 3 shows a Single-phase five-level structure of Diode Clamped Inverter.

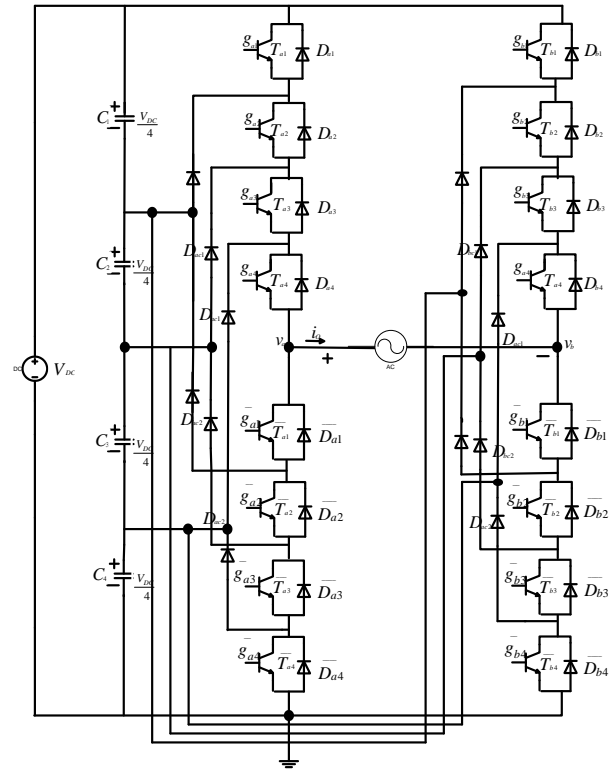

Fig. 3 Power circuit for Single-phase, five-level diode clamped inverter

Finally, single-phase structure of diode clamped five-level inverter is illustrated in Fig. 3. DC voltage source is connected to the inverter circuit through four dividing capacitors which are connected in series. They split the DC link voltage across the capacitors with a constant value equals to $\frac{V_{dc}}{4}$. Thus, the voltage stress of each switch is limited to one capacitor voltage $\frac{V_{dc}}{4}$. For a single-phase five-level full bridge diode clamped inverter, the voltage across the output of the two legs can be equal to 0, $\frac{V_{dc}}{4}$, $\frac{V_{dc}}{2}$, $\frac{3V_{dc}}{4}$ and V_{dc} .

B. ASYNCHRONOUS MOTOR DRIVE

Synchronous speed of Asynchronous Motor varies directly proportional to the supply frequency. Hence, by changing the frequency, the synchronous speed and the motor speed can be controlled below and above the normal full load speed. The voltage induced in the stator, E is directly proportional to the product of slip frequency and air gap flux. The Asynchronous Motor terminal voltage can be considered proportional to the product of the frequency and flux, if the stator voltage is neglected. Any reduction in the supply frequency without a change in the terminal voltage causes an increase in the air gap flux. Asynchronous motors are designed to operate at the knee

point of the magnetization characteristic to make full use of the magnetic material. Therefore the increase in flux will saturate the motor. This will increase the magnetizing current, distort the line current and voltage, increase the core loss and the stator copper loss, and produce a high pitch acoustic noise. While any increase in flux beyond rated value is undesirable from the consideration of saturation effects, a decrease in flux is also avoided to retain the torque capability of the motor. Therefore, the pulse width modulation (PWM) control below the rated frequency is generally carried out by reducing the machine phase voltage, V , along with the frequency in such a manner that the flux is maintained constant. Above the rated frequency, the motor is operated at a constant voltage because of the limitation imposed by stator insulation or by supply voltage limitations [1]. In this paper split-phase single-phase Asynchronous Motor is used as inverter load throughout the simulation process. Fig. 4 shows Split-phase Single-phase Asynchronous Motor.

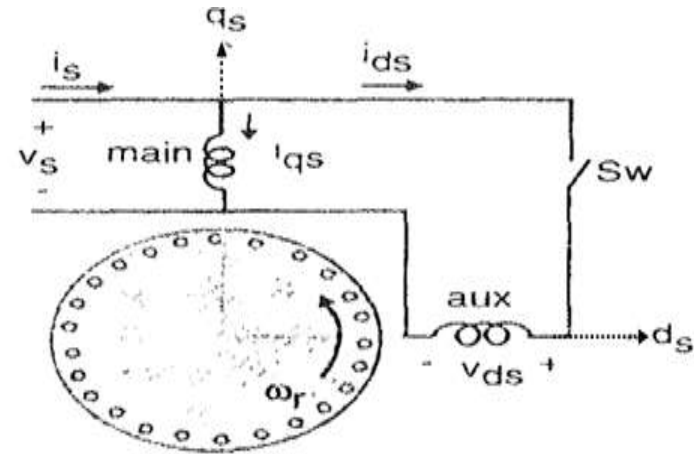

Fig. 4 Split-phase single-phase asynchronous motor

A three-phase symmetrical induction motor upon losing one of its stator phase supplies while running may continue to operate as essentially a single-phase motor with the remaining line-to-line voltage across the other two connected phases. When the main winding coil is connected in parallel with ac voltage, as in the split-phase single-phase asynchronous motor of fig. 4, the current of the auxiliary winding, i_{ds} , leads i_{qs} of the main winding. For even a larger single-phase induction motor, that lead can be further increased by connecting a capacitor in series with the auxiliary winding, this arrangement brings about a Capacitor-start single-phase asynchronous motor.

III. SIMULATION MODEL AND RESULTS

Multilevel inverter fed asynchronous motor drive inverter is implemented in MATLAB SIMULINK which is shown in Fig. 5. The MATLAB SIMULINK model of Single-phase full bridge

of Diode Clamped Multilevel inverter using three-level diode clamped configuration is shown in Fig. 5.

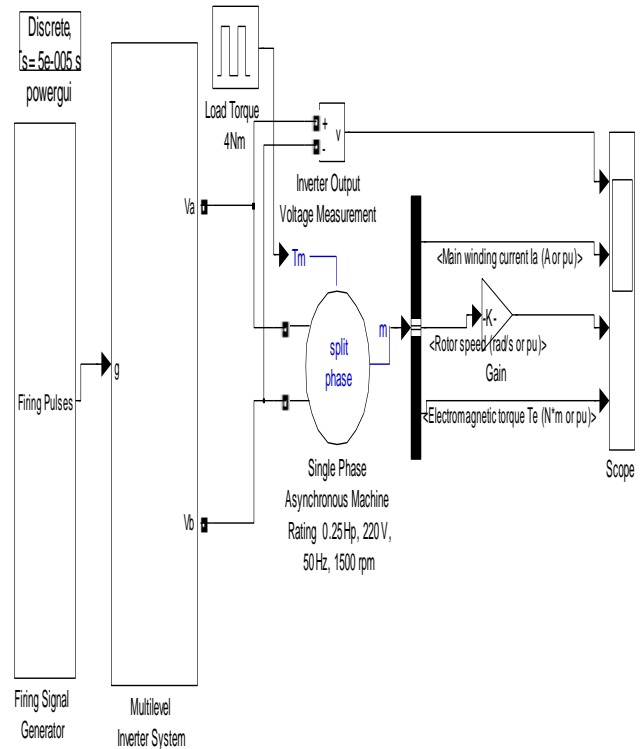

Fig. 5 Matlab/Simulink model of multilevel asynchronous motor drive.

The single-phase three-level diode clamped inverter output voltage after feeding to asynchronous motor is shown in Fig. 6. The stator main winding output current with respect to single-phase is shown in Fig. 7. The Variation in speed is shown in Fig. 8. The machine starts at no load and then at $t=2.0$ sec, once the machine has reached its steady state, the load torque is increased to its nominal value (4 N.m) in 1.0 sec. The speed increases and settles at 1500 rpm without torque load and drops to 1450 rpm when loaded with torque load. The Electromagnetic torque is shown in Fig. 10. The Fast Fourier Transform (FFT) analysis is done for the output voltage and stator main winding current and the corresponding spectrum is shown in Fig. 11 and Fig. 12 respectively. It can be seen that the magnitude of fundamental voltage for three-level inverter fed asynchronous motor drive is 207.6 Volts. The total harmonic distortion is 3.04 percent and the magnitude of fundamental current is 28.6 Amperes. The total harmonic distortion is 1.43 percent.

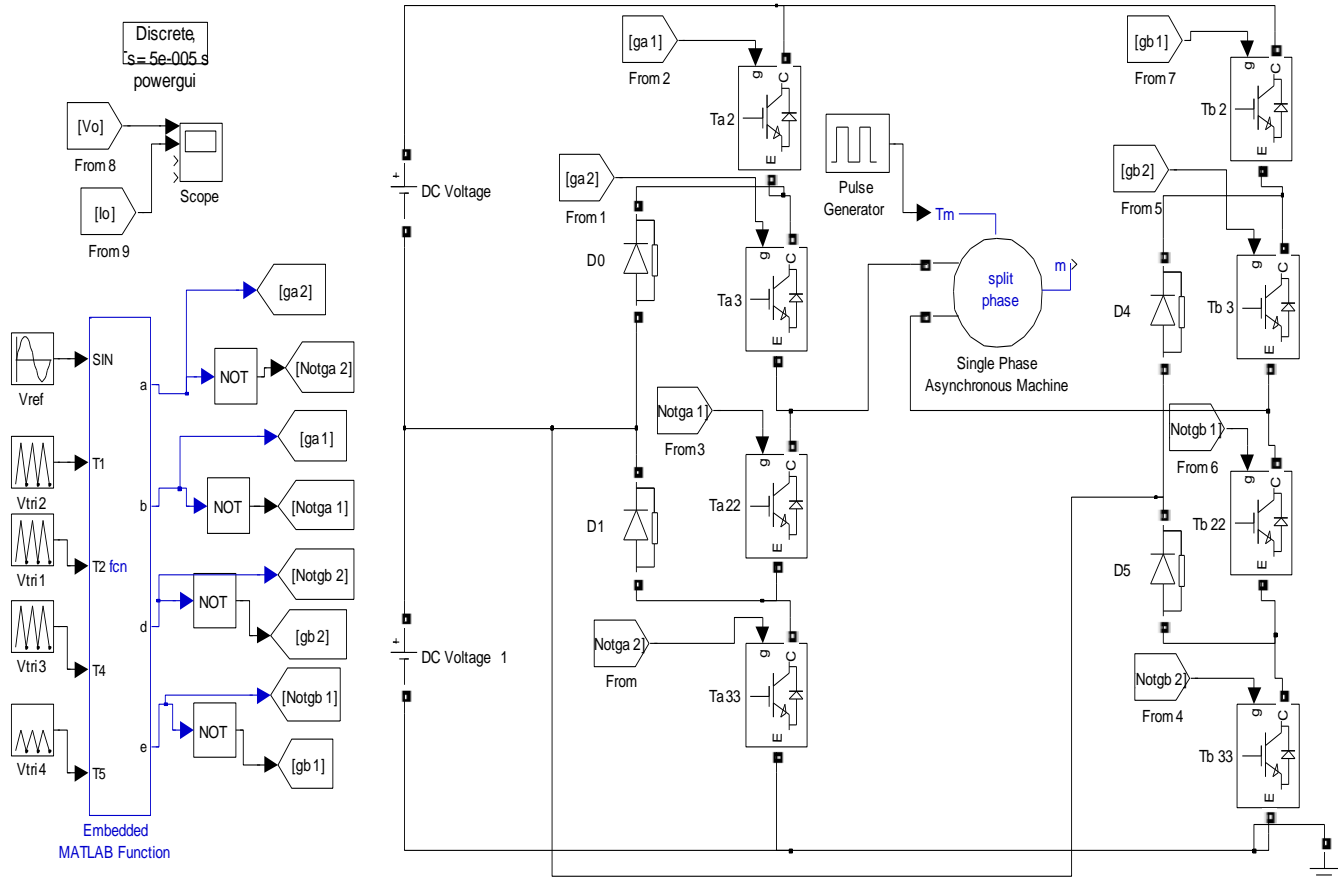

Fig. 6 Matlab/Simulink model of Single-phase Three-level Diode Clamped Inverter

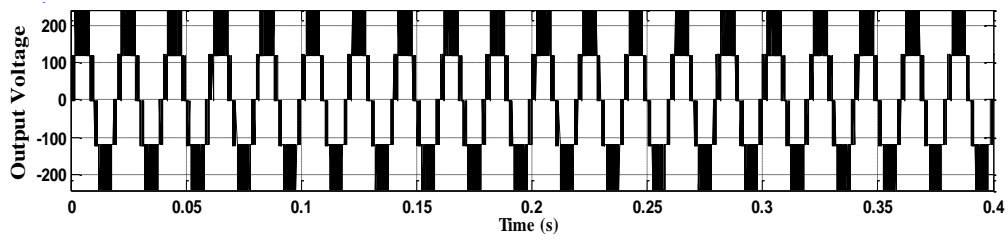

Fig. 7 Single-phase three-level inverter output Voltage

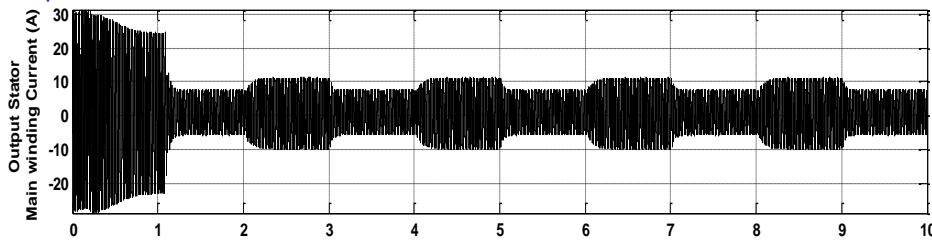

Fig. 8 Single-phase three-level inverter output Stator Main winding current

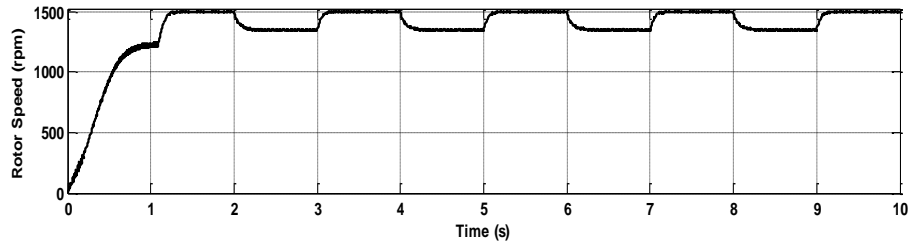

Figure 9: Variation in speed

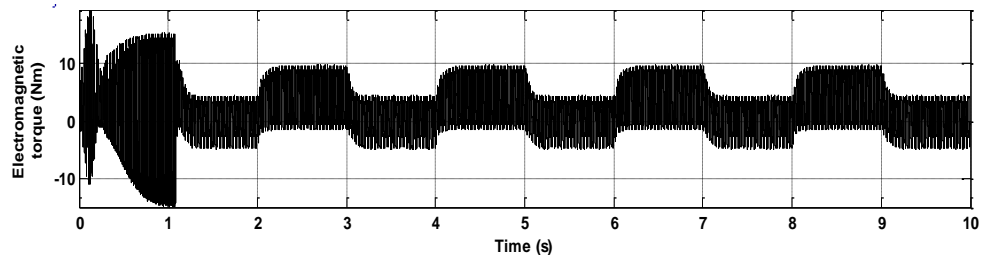

Fig. 10 Variation in electromagnetic torque

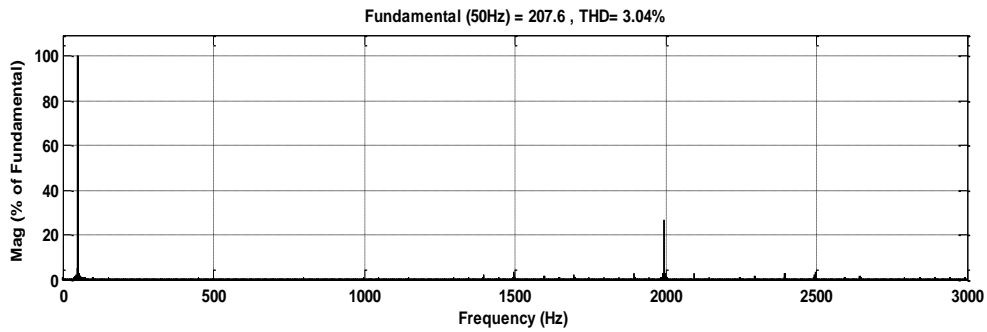

Fig. 11 FFT analysis of voltage

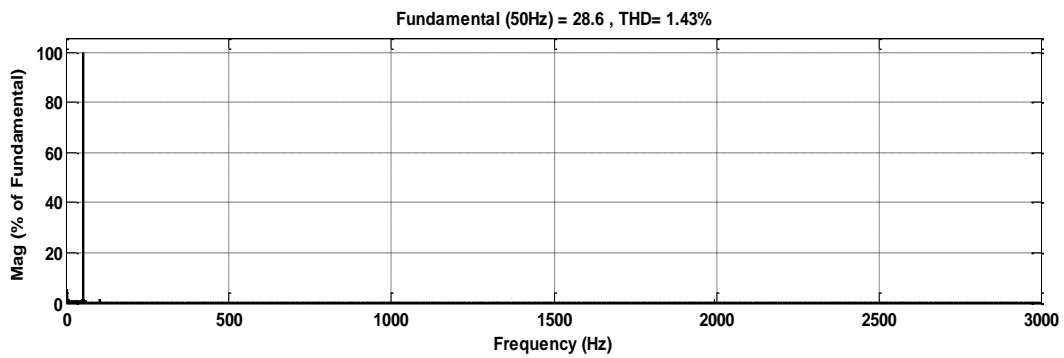

Fig. 12 FFT analysis of current

The MATLAB SIMULINK model of Single-phase of four-level Diode Clamped Inverter configuration is shown in Fig. 13

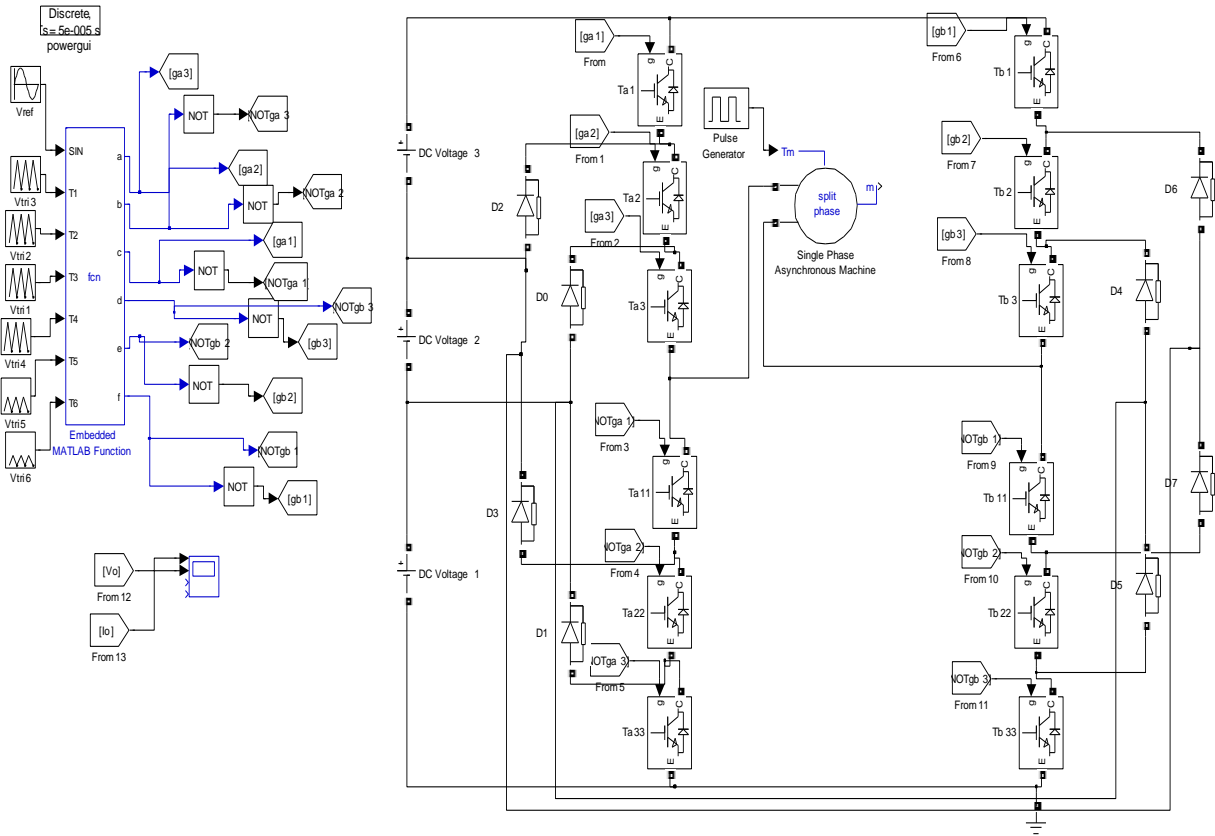

Fig. 13 Matlab/Simulink model of single-phase four-level diode clamped inverter

The single-phase four-level diode clamped inverter output voltage after feeding to asynchronous motor is shown in Fig. 14. The output stator main winding current with respect to single-phase is shown in Fig. 15. The Variation in speed is shown in Fig. 16. The speed increases and settles at 1500 rpm without torque load and drops to 1450 rpm when loaded with torque load of 4 Nm. The Electromagnetic torque is shown in Fig. 17. The Fast Fourier Transform (FFT) analysis is done for

the voltage and output stator main winding current and the corresponding spectrum is shown in Fig. 18 and Fig. 19 respectively. It can be seen that the magnitude of fundamental voltage for four-level inverter fed asynchronous motor drive is 209.5 Volts. The total harmonic distortion is 2.32 percent and the magnitude of fundamental current is 28.74 Amperes. The total harmonic distortion is 0.99 percent.

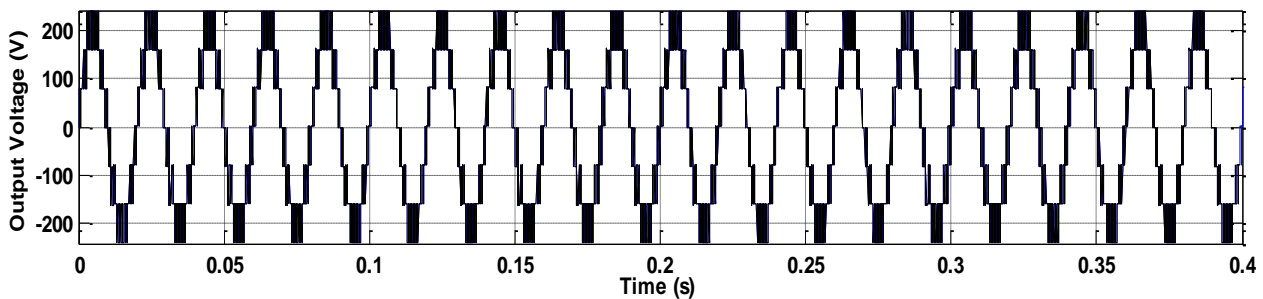

Fig. 14 Single-phase four-level inverter output voltage

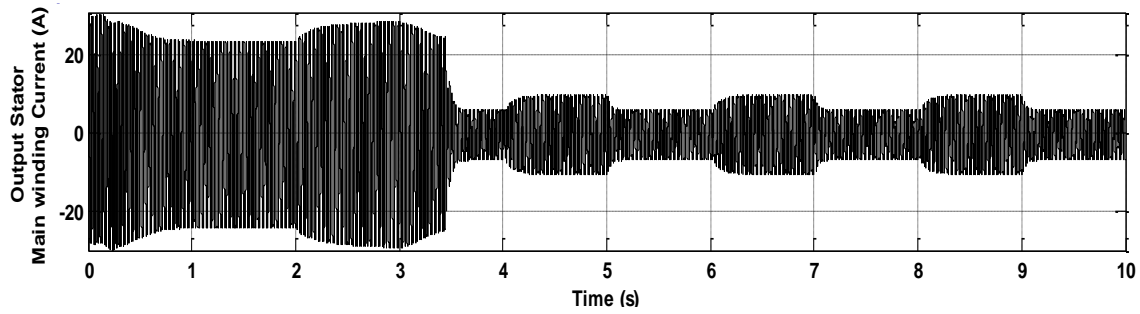

Fig. 15 Single-phase four-level inverter output stator main winding current

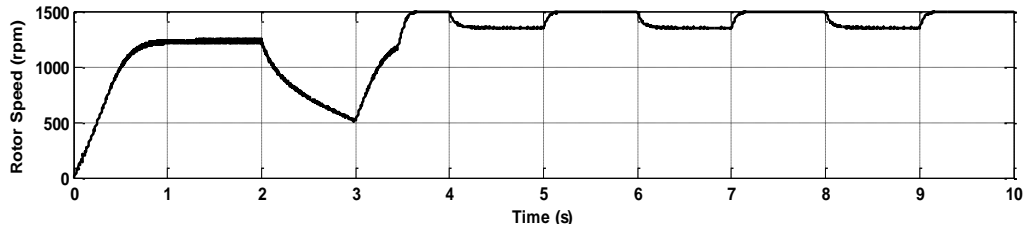

Fig. 16 Variation in speed

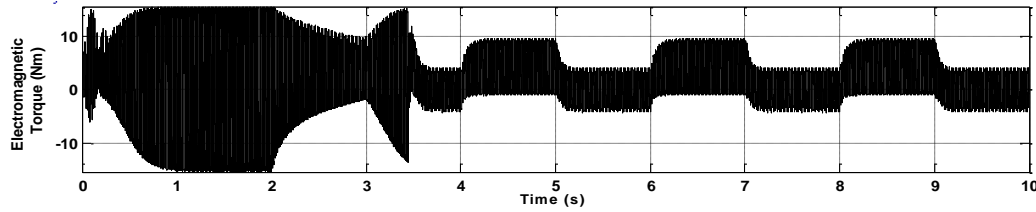

Fig. 17 Variation in electromagnetic torque

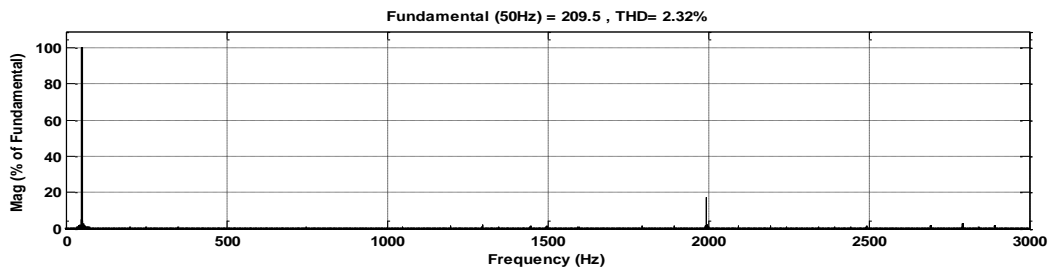

Fig. 18 FFT analysis of voltage

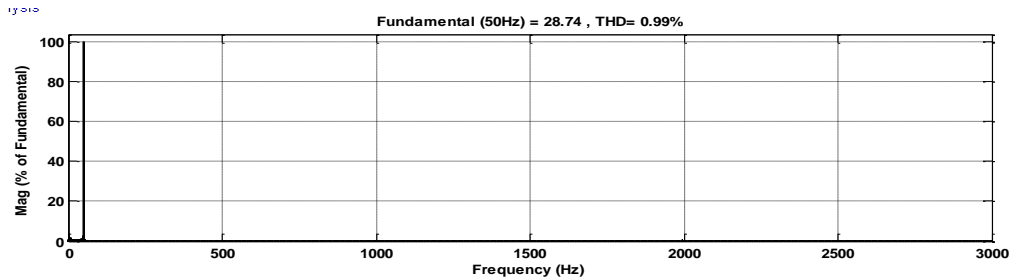

Fig.19 FFT analysis of current

The MATLAB SIMULINK model of Single-phase of five-level Diode Clamped Inverter configuration is shown in Fig. 20

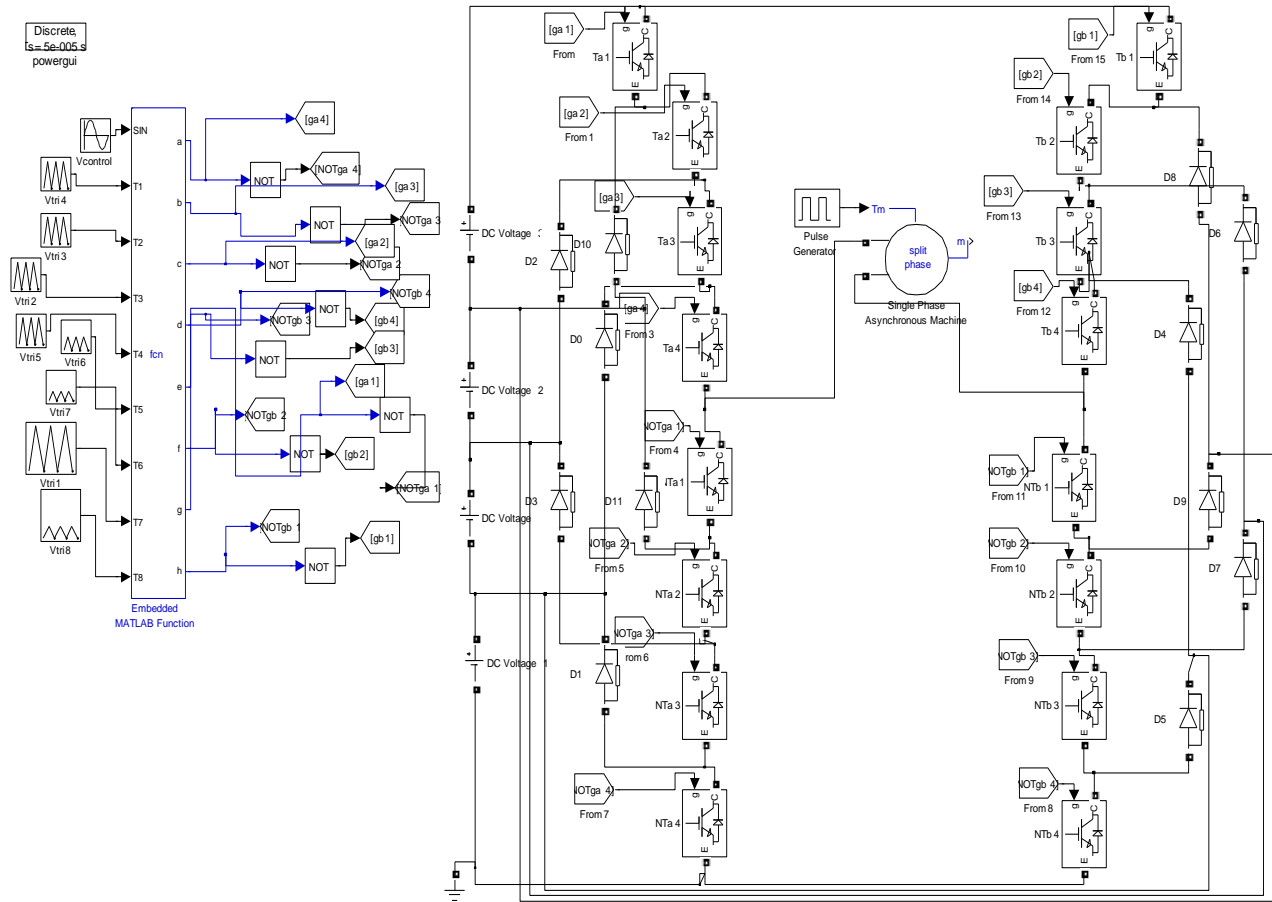

Fig. 20 Matlab/Simulink model of single-phase five-level diode clamped inverter

The single-phase five-level diode clamped inverter output voltage and output stator main winding current and the corresponding spectrum is shown in Fig. 21. The output stator main winding current with respect to single-phase is shown in Fig. 22. The Variation in speed is shown in Fig. 23. The speed increases and settles at 1500 rpm without torque load and drops to 1450 rpm when loaded with torque load of 4 Nm. The Electromagnetic torque is shown in Fig. 24. The Fast Fourier Transform (FFT) analysis is done for

the voltage and output stator main winding current and the corresponding spectrum is shown in Fig. 25 and Fig. 26 respectively. It can be seen that the magnitude of fundamental voltage for five-level inverter fed asynchronous motor drive is 208.2 Volts. The total harmonic distortion is 1.70 percent and the magnitude of fundamental current is 28.58 Amperes. The total harmonic distortion is 0.84 percent.

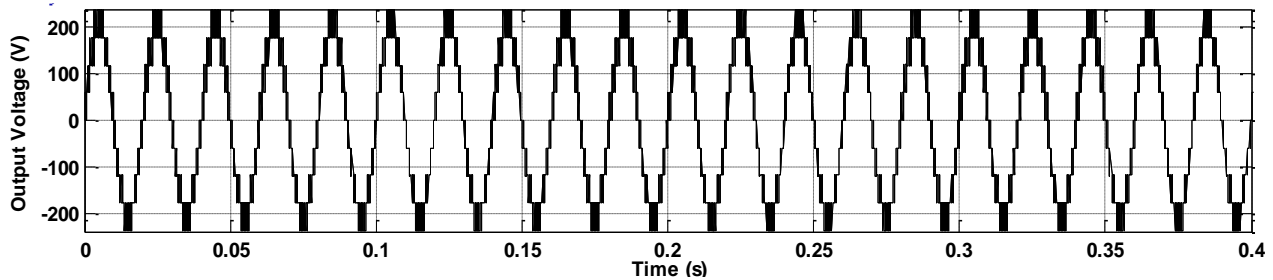

Fig. 21 Single-phase five-level inverter output voltage

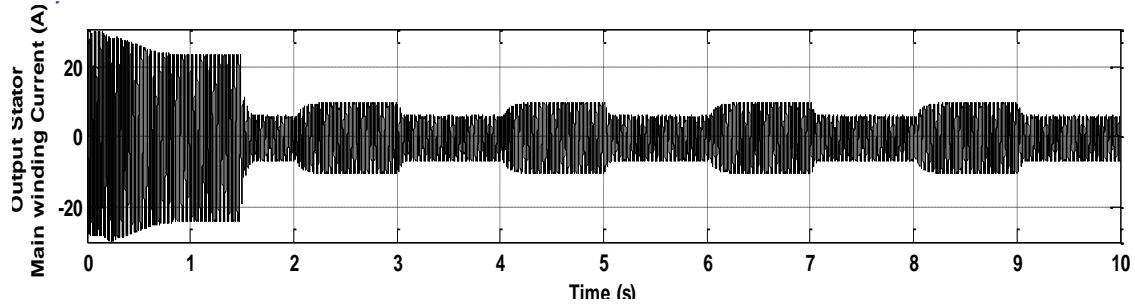

Fig. 22 Single-phase five-level inverter output stator main winding current

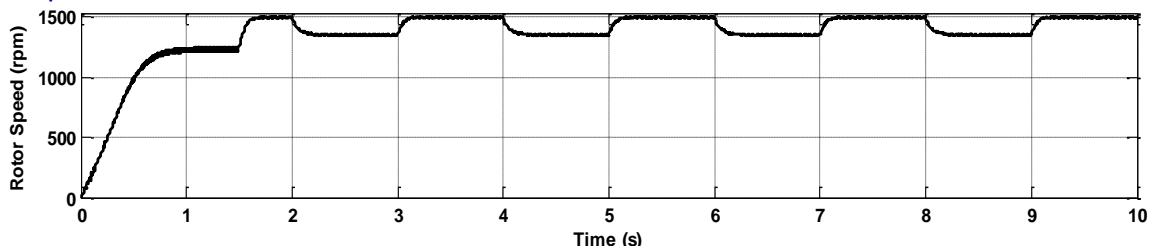

Fig. 23 Variation in speed

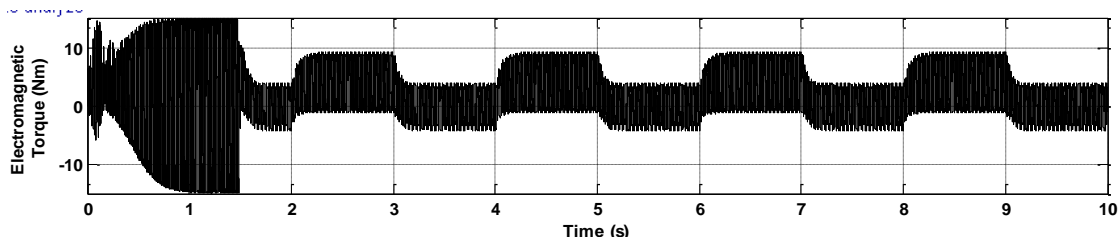

Fig. 24 Variation in electromagnetic torque

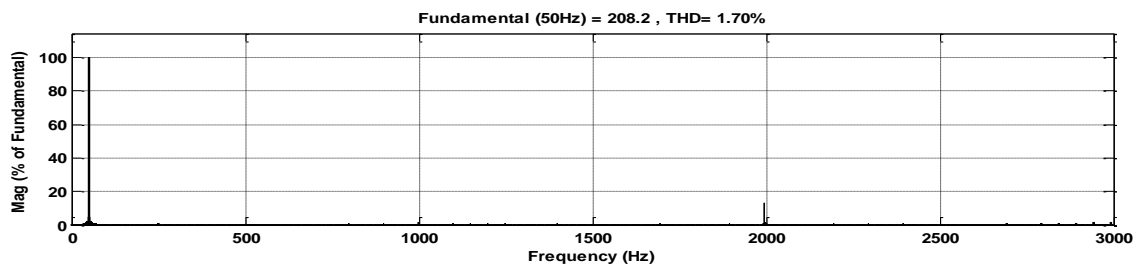

Fig. 25 FFT analysis of voltage

The results are tabulated in Table I below:

TABLE I
THE ANALYSIS OF THREE-LEVEL, FOUR-LEVEL and FIVE- LEVEL DIODE

| Parameters | Diode Clamped Multilevel Inverter | | |
|---------------------|-----------------------------------|---------------------|---------------------|
| | Three-level Inverter | Four-level Inverter | Five-level Inverter |
| Voltage Level (V) | 207.6 | 209.5 | 208.20 |
| THD for Voltage (%) | 3.04 | 2.32 | 1.70 |
| Current Level (A) | 28.6 | 28.74 | 28.58 |
| THD for Current (%) | 1.43 | 0.99 | 0.84 |

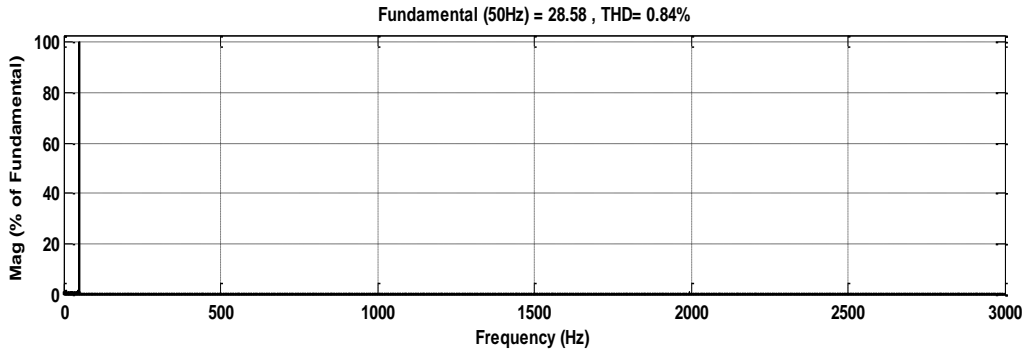

Fig. 26 FFT analysis of Current

IV. CONCLUSIONS

Three-level, Four-level and Five-level Diode Clamped inverter fed asynchronous motor drive are simulated using the blocks of Matlab/Simulink/SimPowerSystems. The results of three-level, four-level and five-level systems are compared. It is observed that the total harmonic distortion produced by the five-level inverter system is less than those of three-level and four-level inverter fed drive system. Therefore the heating due to five-level inverter system is less than those of three-level and four-level inverter fed drive system. The switching losses due to five-level inverter system is higher than those of three-level and four-level inverter fed system because of high number of power switches involved in the design. The simulation results of voltage, current, electromagnetic torque, speed and spectrum are presented. This drive system can be used in industries where adjustable speed drives are required to produce output with reduced harmonic content. The scope of this work is the

modeling and simulation of three-level, four-level and five-level inverter fed asynchronous motor drive systems. An Improved Multilevel topology will be used to drive the asynchronous motor in future work. Five-level or higher level inverter system is a viable alternative since it has better performance.

REFERENCES

- [1] Manasa, S., Balajiramakrishna, S., Madhura, S. and Mohan, H. M., “Design and Simulation of Three Phase Five Level and Seven Level inverter fed Induction Motor Drive with Two Cascaded H-Bridge Configuration”, International Journal of Electrical and Electronics Engineering (IJEEE), , vol. 1, pp. 2231-5284 2012.
- [2] Tolbert, L. M., Peng, F. Z. and Habetler, T. G., “Multilevel Converters for Large Electric Drives”, IEEE Transactions on Industry Applications, vol. 35, no. 1, pp. 36–44, 1999.
- [3] Pandian, G. and Rama, R. S., “Implementation of Multilevel Inverter-Fed Induction Motor Drive”, Journal of Industrial Technology, vol. 24, pp. 109–119, 2008.
- [4] Neelashetty, Kashappa and Ramesh, Reddy, “Performance Of Voltage Source Multilevel Inverter – Fed Induction Motor Drive Using Simulink”, ARPN Journal of Engineering and Applied Sciences, vol. 6, no. 6, pp. 1819-6608, 2011.

- [5] Rodríguez, J., Lai, J. S. and Peng, F. Z., “Multilevel inverters: A Survey of Topologies, Controls, and Applications”, IEEE Transactions on Industrial Electronics, vol. 49, no. 4, pp. 724-738, 2002.
- [6] Lai, J. S. and Peng, F. Z., “Multilevel Converters-a New Breed of Power Converters”, IEEE Transactions on Industry Applications, vol. 32, no. 3, pp. 509-517, 1996.
- [7] Shivakumar, E.G., Gopukumar, K., Sinha S. K. and Ranganathan, V.T., “Space Vector PWM Control of Dual Inverter Feed-open-end Winding induction Motor Drive”, IEEE APEC Conf., vol. 1, pp. 399-405, 2001
- [8] Dixon, J. and Moran, L.,” High-level Multi-Step Inverter Optimization using a Minimum number of Power Transistors “, IEEE Tran. Power Electron, vol. 21, no.23, pp. 30-337, 2006.
- [9] Murugesan, M., Sakthivel, R., Muthukumaran, E and Sivakumar, R. “Sinusoidal PWM Based Modified Cascaded Multilevel Inverter”, International Journal of Computational Engineering Research, vol. 2, no. 2, pp. 529-539, 2012.
- [10] Surin, Khomfoi and Tolbert, L. M., “Multilevel Power Converters”, University of Tennessee, www.google.com/m/url/channel=n&wclient/wed.eecs.utk.edu/~tolbert/publications/multilevel_book_chapter.pdf, 2012.
- [11] Kith Corzine, “Operation and design of Multilevel Inverters”, Developed for the office of Naval research, 2003.