

# Automatic Broken Track Detection Using LED-LDR Assembly

Avinash.Vanimireddy<sup>1</sup>,D.Arana Kumari<sup>2</sup>

<sup>1</sup>M.Tech,ECM Department,KL University,Vaddeswaram,A.P,India

<sup>2</sup>Associate Professor,ECM Department,KL University,Vaddeswaram,A.P,India

**Abstract**—In India rail transport occupies a prominent position in providing the necessary transport infrastructure to sustain needs of a rapidly growing economy. Today,India possesses the fourth largest railway network in the world. However, in terms of the reliability and safety parameters, we have not yet reached truly global standards. The main problem about a railway analysis is detection of cracks in the structure. If these deficiencies are not controlled at early stages they might lead to a number of derailments resulting in a heavy loss of life and property. This paper proposes a cost effective solution to the problem of railway track crack detection utilizing LED-LDR assembly which tracks the exact location of faulty track which then mended immediately so that many lives will be saved.

**Keywords:**Railwaytrack,crackdetection,ARM,GSM,GPS,Auto matic Rail crack detection,GPRS

## I. INTRODUCTION

Transport is a key necessity for specialization that allows production and consumption of products to occur at different locations. Transport has throughout history been a spur to expansion as better transport leads to more trade. Economic prosperity has always been dependent on increasing the capacity and rationality of transport[1]. But the infrastructure and operation of transport has a great impact on the land and is the largest drainer of energy, making transport sustainability and safety a major issue. In India, we find that rail transport occupies a prominent position in providing the necessary transport infrastructure to sustain and quench the ever-burgeoning needs of a rapidly growing economy[4].The Indian railway network today has a track length of 113,617 kilometres (70,598 mi).over a route of 63,974 kilometres (39,752 mi) and 7,083 stations[11]. It is the fourth largest railway network in the world exceeded only by those of the United States, Russia and China. The rail network traverses every length and breadth of India and is known carry over 30 million passengers and 2.8 million tons of freight daily. Despite boasting of such impressive statistics, the Indian rail network is still on the growth trajectory trying to fuel the economic needs of our nation.In terms of the reliability and safety parameters, we have not yet reached truly global standards.Though rail transport in india growing at a rapid pace, the associated safety infrastructure facilities have not kept up with the aforementioned proliferation. Our facilities

are inadequate compared to the international standards and as a result, there have been frequent derailments that have resulted in severe loss of valuable human lives and property as well[6]. The principal problem has been the lack of cheap and efficient technology to detect problems in the rail tracks and of course, the lack of proper maintenance of rails which have resulted in the formation of cracks in the rails and other similar problems caused by anti-social elements which jeopardize the security of operation of rail transport.[4]

## II.RELATED WORK

In general, there exist three main categories of techniques currently used for damage identification and condition monitoring of Railway tracks. These include:

- Visual inspections
- Non-destructive testing (NDT) technologies such as acoustic emissions or ultrasonic methods, magnetic field methods, radiography,eddy current techniques, thermal field methods, dye penetrant, fibre optic sensors of various kinds
- Vibration-based global methods.

visual inspection is the primary technique used for defect identification in tracks, and is effectively used in specialised disciplines. The successful implementation of this method generally requires the regions of the suspected damage to be known as a first step, and be readily accessible for physical inspection. As a result, this method can be costly, time consuming and ineffective for large and complex structural systems such as the rail track[3].

NDT techniques has resulted in a number of tools for us to choose from. Among the inspection methods used to ensure rail integrity, the common ones are ultrasonic inspection and eddy current inspection. Ultrasonic Inspections are common place in the rail industry in many foreign countries. It is a relatively well understood technique and was thought to be the best solution to crack detection[6].The Ultrasonic Broken Rail Detector system is the first and only alternative broken rail detection system developed, produced and implemented on a large scale. By using ultrasonic Broken Rail Detector system railway operators will have the benefit of monitoring rails continuously for broken rails without human intervention. This will contribute to ensure that the people does not suffer losses as a result of train derailments[10].Ultrasonics

can only inspect the core of materials; that is, the method cannot check for surface and near-surface cracking where many of the faults are located[6].



Fig.1 Ultrasonic Broken Rail Detector

Another method for detection of cracks on tracks is by using wireless sensor networks. In this method the detection of Cracks can be identified using IR rays with the IR transmitter & receiver. IR receiver is connected to the Signal Lamp or Electrified lamp with the IR sensor. CAN controller is connected to the main node and it send the information via GSM and transmit the message to engine and to the nearest station. The detection of Cracks can be identified using IR rays and IR sensor. IR receiver is connected to the signal lamp and to the CAN controller. The electrified lamp is nothing but it sides of the tracks the electric lamp which is current flowing for the engines transportation[2],[9]. But this type of system doesn't locate small cracks and the system is also costly.

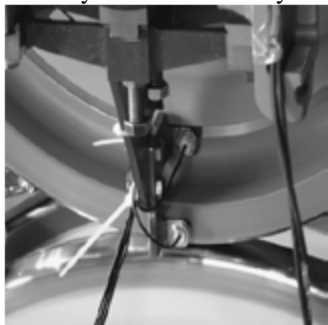

Fig.2 Model Figure to Fix the IR Sensor on the Wheel

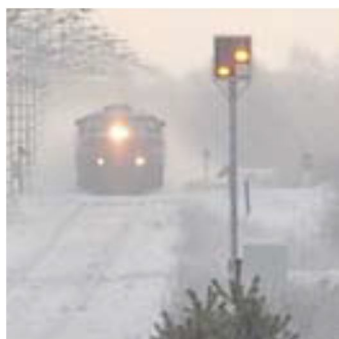

Fig.3 Signal Lamp Example

### III. CURRENT SYSTEM

In the Current System the principle involved in crack detection is the concept of LDR (Light dependent Resistor). In the proposed design, the LED will be attached to one side of the rails and the LDR to the opposite side. During normal operation, when there are no cracks, the LED light does not fall on the LDR and hence the LDR resistance is high. Subsequently, when the LED light falls on the LDR, the resistance of the LDR gets reduced and the amount of reduction will be approximately proportional to the intensity of the incident light. As a consequence, when light from the LED deviates from its path due to the presence of a crack or a break, a sudden decrease in the resistance value of the LDR ensues. This change in resistance indicates the presence of a crack or some other similar structural defect in the rails. In order to detect the current location of the device in case of detection of a crack, a GPS receiver whose function is to receive the current latitude and longitude data is used. To communicate the received information, a GSM modem has been utilized. The function of the GSM module being used is to send the current latitude and longitude data to the relevant authority as an SMS. The robot is driven by four DC motors. With this current system only latitudes and longitudes of the broken track will only be received so that the exact location cannot be known[6].

### IV. PROPOSED SYSTEM

The proposed system will overcome the limitations of both the traditional and the current system that are using for detection of faulty tracks. In the current system we don't get the exact location of the faulty track. We only receive latitudes and longitudes of the location. In the proposed system we are using a GPRS module so that we can get the exact location of the broken rail track. In this proposed system we are also using an ARM7 controller which consumes low power and also less cost. By using the ARM controller the analysis time of the proposed will be reduced drastically. Before the start of the railway line scan the robot has been programmed to self-calibrate the LED-LDR arrangement. It is necessary because the LDR has a natural tendency to show a drifting effect because of which, its resistance under the same lighting condition may vary with time. After calibration, the robot waits for a predetermined period of time so that the onboard GPS module starts reading the correct geographic coordinate. This is necessary because any GPS module will take some time to synchronize with the satellites. The principle involved in crack detection is the concept of LDR. In the proposed design, the LED will be attached to one side of the rails and the LDR to the opposite side. During normal operation, when there are no cracks, the LED light does not fall on the LDR and hence the LDR resistance is high. Subsequently, when the LED light falls on the LDR, the resistance of the LDR gets reduced and the amount of reduction will be approximately proportional to the intensity of the incident light. As a consequence, when light from the LED deviates

from its path due to the presence of a crack or a break, a sudden decrease in the resistance value of the LDR ensues. This change in resistance indicates the presence of a crack or some other similar structural defect in the rails. In order to detect the current location of the device in case of detection of a crack, a GPS receiver whose function is to receive the current latitude and longitude data is used. To communicate the received information, a GSM modem has been utilized. The GSM modem transfers the received information to the GPRS which then shows the exact location of the faulty rail track in the mobile

well suited for communication gateways and protocol converters, soft modems, voice recognition and low end imaging, providing both large buffer size and high processing power[14].

2) *GPS Module:* SR-92 GPS receiver has been used as the GPS module. SR-92 is a low-power, ultra-high performance, easy to use GPS smart antenna module based on SiRF's third generation single chip. The 5-pin I/O interface is then connected to the main board with either connector or wire soldering. The main features of GPS module includes

- High tracking sensitivity of -159dBm
- Low power consumption of 40mA at full tracking
- Built-in backup battery allowing hot/warm starts and better performance
- Hardware power saving control pin allowing power off GPS via GPIO[8].

3) *GSM Module:* The SIM 300 GSM module has been chosen to achieve the SMS functionality. Featuring an industry-standard interface, the SIM300 delivers GSM/GPRS 900/1800/1900Mhz performance for voice, SMS, data and Fax in a small form factor and with low power consumption. The leading features of SIM300 make it deal fir virtually unlimited application, such as WLL applications, M2M application, handheld devices and much more[13].

4) *LED-LDR Assembly:* The common 5V LED and cadmium sulphide LDR was found to be sufficient. The LED is powered using one of the digital pin of the ARM controller. The LDR and a 45kΩ resistor form a potential divider arrangement. The output of the potential divider is given to one of the analog input channel of the ARM. The LDR is calibrated every time the robot is used. The light dependent resistor or cadmium sulfide (CdS) cell is a resistor whose resistance decreases with increasing incident light intensity.

5) *GPRS Module:* In this system the Gprs module is used to know the exact location of the broken rail track. The GSM modem sends the coordinates of the faulty rail track to the GPRS which then sends the exact location to the mobile

6) *DC Motor:* The proposed design uses 4 DC motors (Torque Rating: 10Kg and Speed Rating: 500 rpm) interfaced with the ARM With a wheel diameter of 5.2 cm and the total mass of around 5 Kg[6]. The approximate speed of the robot is around 0.5 metres/sec.

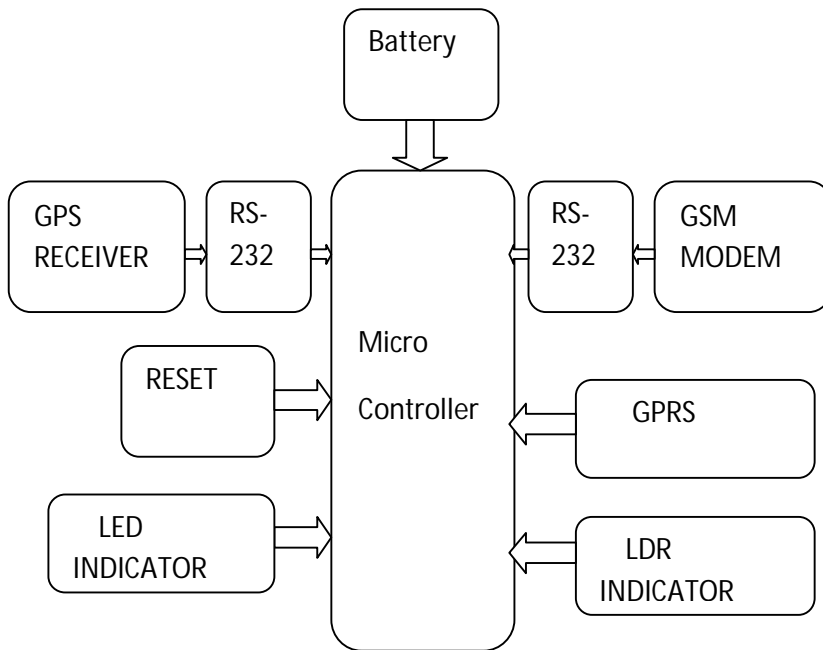

Fig.4 Automatic Broken Rail Detection Scheme using LED-LDR Assembly

#### A. System Architecture

The proposed rail track detection system architecture consists of ARM7 controller, GPS, GSM, LED-LDR Assembly, GPRS, DC Motor.

#### B. Operation

This section explains the operation of modules present in the faulty rail track detection system architecture

1) *MicroController:* The microcontroller used in this system is LPC2148 microcontroller that is based on a 32/16 bit ARM7TDMI-S CPU with real-time emulation and embedded trace support, that combines the microcontroller with embedded high speed flash memory ranging from 32 kB to 512 kB. Due to their tiny size and low power consumption, LPC21418 are ideal for applications where miniaturization is a key requirement, such as access control and point-of-sale. A blend of serial communications interfaces ranging from a USB 2.0 Full Speed device, multiple UARTs, SPI, SSP to I2Cs, and on-chip SRAM of 8 kB up to 40 kB, make these devices very

#### V.Conclusion

The proposed broken rail detection system automatically detects the faulty rail track without any human intervention. There are many advantages with the proposed system when compared with the traditional detection techniques. The advantages include less cost, low power consumption and less analysis time. By this proposed system the exact location of the faulty rail track can easily be located which will be mended immediately so that many lives can be saved.

#### REFERENCES

- [1] Non invasive rail track detection system using Microwave sensor, K. Vijayakumar, S.R.Wylie, J.D.Cullen, C.C. Wright, A.I. Al-Shamma'a
- [2] Detection of Cracks and Railway Collision Avoidance System, S. Ramesh 2010-2011
- [3] High Speed Detection of Broken Rail, Rail Cracks and Surface Faults
- [4] High speed detection of broken rails, rail cracks and surface faults, Prof. M Dhanasekar, Wirtu, L Bayissa & M Dhanasekar
- [5] Transverse and longitudinal crack detection in the head of rail tracks using Rayleigh wave-like wideband guided ultrasonic waves, Stuart B Palmer, Steve Dixon, Rachel S Edwards and Xiaoming Jian
- [6] Robust Railway Crack Detection Scheme (RRCDS) Using LED-LDR Assembly, Selvamraju, Somalraju, Vigneshwar Murali, Gourav Saha, Dr. V. Vaidehi
- [7] Rail crack detection: an infrared approach to in-service track monitoring, Richard J. Greene, John R. Yates, Eann A. Patterson
- [8] [http://en.wikipedia.org/wiki/Global\\_Positioning\\_System](http://en.wikipedia.org/wiki/Global_Positioning_System)
- [9] Railway Faults Tolerance Techniques using Wireless Sensor Networks, S. Ramesh, S. Gobinathan
- [10] The most advanced system for broken rail detection
- [11] <http://www.tc.gc.ca/media/documents/railsafety/technologies.pdf>
- [12] <http://www.seeedstudio.com/depot/images/product/sr-92.pdf>
- [13] <http://en.wikipedia.org/wiki/GSM>
- [14] [http://www.wvshare.com/datasheet\\_html/LPC2148-PDF.html](http://www.wvshare.com/datasheet_html/LPC2148-PDF.html)