

Original Article

Integrating Wind Power for a Sustainable Future: A Simulation Analysis of Battery Storage, Transmission, and System Performance

Sandeep Ushkewar¹, Ashwini Patil², Gaurav Patil³, S.P. Deshmukh⁴, S.K. Bhil⁵

^{1,3}*SVKM's Institute of Technology, Maharashtra, India.*

²*Gangamai College of Engineering, Maharashtra, India.*

⁴*Institute of Chemical Technology, Maharashtra, India.*

⁵*Veermata Jijabai Technological Institute, Maharashtra, India.*

¹*Corresponding Author : sandeep.ushkewar@ieee.org*

Received: 02 August 2024

Revised: 11 December 2024

Accepted: 17 December 2024

Published: 31 January 2025

Abstract - The escalating demand for sustainable energy solutions has propelled advancements in wind power. Wind's variable nature presents a significant challenge – guaranteeing uninterrupted and consistent electricity delivery. This research addresses this challenge by investigating the integration of battery storage and optimized transmission line management for maximizing wind power utilization and efficiency. Wind's intermittency poses a major obstacle for grid operators, obstructing the real-time supply-demand balance for grid stability. Battery storage offers a solution by capturing excess wind energy during high output periods and providing a readily available power source during low wind. This flexibility reduces energy curtailment, enhances grid stability, and improves overall wind power utilization. This work deals with the impact of battery storage capacity and transmission line strength on the performance of a simulated wind power system. Work employs a modeling and simulation approach, developing mathematical models for wind turbines, battery storage, transmission lines, and electrical load. Simulating the system under various scenarios aims to identify optimal system configurations that minimize energy curtailment, enhance grid stability, and improve overall system efficiency. This analysis is expected to provide valuable insights into the optimal configuration of battery storage and transmission line capacity for wind power integration. The findings hold the potential to significantly contribute to the development of reliable and more economical wind energy systems, accelerating the transition towards a sustainable future.

Keywords - Battery storage, Grid stability, Renewable energy systems, Transmission line management, Wind turbine system.

1. Introduction

Driven by concerns about climate change and the finite nature of fossil fuels, wind power has become the fastest-growing renewable energy source globally, with its installed capacity surging by 63% in the last decade alone. This rapid rise is attributed to its clean energy generation and declining costs. However, its intermittent nature poses challenges for grid integration, demanding innovative solutions to optimize its utilization and reliability.

This paper explores the integration of battery storage and transmission line management into a wind power system, providing a comprehensive analysis of their impact on system performance. The incorporation of battery storage addresses the intermittency of wind power. It operates by holding onto additional energy during times of strong output and delivering it later when wind output diminishes. This flexibility reduces energy curtailment, enhances grid stability, and improves

overall wind power utilization. Transmission line management plays a crucial role in effectively delivering wind-generated electricity to load centers. Optimizing transmission line capacity and routing minimizes transmission losses, improves system efficiency, and facilitates integration of large-scale wind power projects.

This paper delves into the interplay between wind power, battery storage, and transmission line management, investigating the optimal configuration of these components to maximize system performance. Through modeling and simulation techniques, we evaluate the impact of battery storage capacity and transmission line capacity on various performance metrics, including energy curtailment, grid stability, and overall system efficiency. The findings offer insightful analysis of the style and functioning of wind-powered systems, helping to create future renewable energy solutions more dependable and sustainable.



1.1. Objective

This work focuses on optimizing the integration of wind power into the grid by analyzing the interplay between wind generation, battery storage capacity, and transmission line management. The paper aims to identify configurations that minimize energy curtailment, enhance grid stability, and improve overall system efficiency. We evaluate the impact of varying battery storage capacities and transmission line configurations on key performance metrics through modelling and simulation techniques. These insights will be valuable for maximizing wind power utilization and its contribution to a sustainable future energy landscape.

1.2. Subject of Investigation

This work investigates the combination of transmission lines, battery storage, and windmill management in a simulated wind power system. The paper aims to understand how these components interact and impact the system's overall performance.

2. System parameters and Assumptions

2.1. Wind Turbine Power Generation

The power coefficient typically varies based on the turbine's architecture and the wind velocity.

$$P_{wind} = 0.5 \times \rho \times A \times v^3 \times C_p \quad (1)$$

Where,

P_{wind} is the wind engine power output (watts)

ρ is the volume of the atmosphere (kg/m^3)

A is the rotor wings' raked region. (m^2)

V denotes wind velocity (m/s)

C_p denotes the power ratio

A dimensionless metric called the power coefficient connects the turbine's actual power production to its highest energy potential, which might be obtained from wind.

2.1.1. Battery Storage

The state of charge at time t% can be given as,

$$SOC_t = SOC_{t-1} \times \eta_{charge} \times \Delta_t \times P_{charge} \times \eta_{discharge} \times \Delta_t \times P_{discharge} \quad (2)$$

Where,

$SOC_{(t)}$ denotes the state of charge at time t (percent)

$SOC_{(t-1)}$ denotes the state of charge at the previous time step t-1 (percent)

η_{charge} denotes the charging efficiency (percent)

Δ_t denotes the time step (seconds)

P, charge denotes the charging power (watts)

P, discharge denotes the discharging power (watts)

This determines a battery's State of Charge (SOC). The battery's remaining energy is indicated by its level of charge.

When the SOC is 100%, the battery is completely full; when it is 0%, the battery pack is totally depleted.

2.1.2. Transmission Line Losses

The transmitting line's conductivity measures its ability to resist the flow of electricity.

$$P_{loss} = R \times I^2 \quad (3)$$

Where,

P loss is the power loss (watts)

I is the current flowing in the transmission line (amps)

R is the resistance of the transmission line (ohms/km)

The higher the resistance, the more power will be lost as heat during transmission.

3. Proposed Methodology

This section outlines the methodology employed to investigate the optimal configuration for a wind power system integrated with battery storage and transmission line management. The intermittency of generation is a critical issue for the battery sizing to Store excess energy. When production is high and its discharge when production is low.

Battery storage configuration impacts grid stability. The seasonal analysis emphasises the importance of accounting for real-world criteria, especially Viability in wind power generation and energy demand over season. High wind production during off-peak demand hours can lead to the need for longer-distance transmission, resulting in greater losses. Including optimisation techniques reduces transmission losses, increases system efficiency, and contributes to positive grid stability. The sensitivity analysis will show trade-offs between factors such as storage and transmission, allowing for more resilient and efficient infrastructure development.

3.1. System Modelling

A wind farm model is developed, representing the power generation characteristics of three wind turbines. This model incorporates variations in wind speed and power output.

- A battery storage system model is integrated, considering its capacity, charging/discharging efficiency, and control strategies (e.g., cycle depth, real-time vs. scheduled discharge).
- The transmission line model considers the underground cables connecting the wind farm to the grid. It accounts for factors like cable resistance and reactance that impact power losses during transmission.
- A constant impedance power load with a variable load profile represents the electrical demand on the system.
- Power transformation is modeled using a step-up transformer at the wind farm and a step-down transformer at the grid connection point.

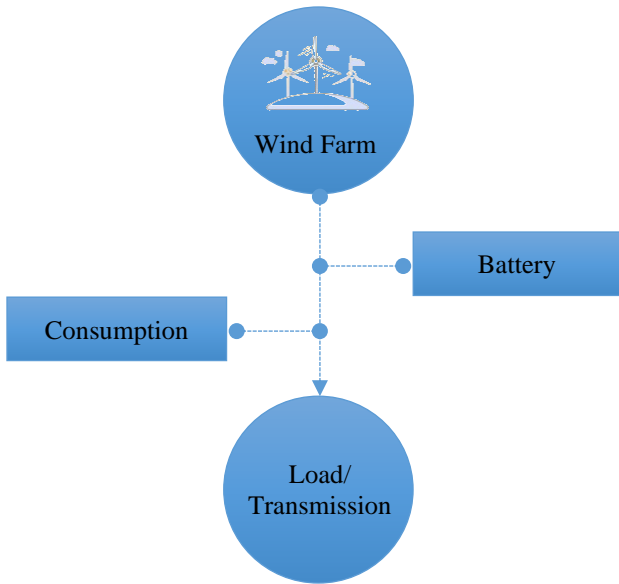

Fig. 1 Wind farm's schematic

A micro grid controller model is included, representing the intelligent control system responsible for optimizing energy flow, battery operation, and grid interaction.

3.2. Simulation Tools and Techniques

The power system modeling software used for this research is MATLAB and MATLAB Simulink. To identify configurations that minimize energy curtailment, enhance grid stability, and improve efficiency, optimization algorithms will be employed (e.g., genetic algorithms and particle swarm optimization).

3.2.1. Data Analysis

The simulation results will be analyzed to evaluate the impact of varying battery storage capacity and transmission line configurations. This analysis will involve metrics such as:

- Energy curtailment rate
- Voltage stability indices
- System efficiency calculations

3.3. Working Algorithm of the System

If the battery is not completely charged, the wind farm's output is used to top it off. If the wind farm's output is insufficient, the power system or the battery supply the remaining electricity. Switches on wind turbines turn on, and all produced energy is provided to the consumer once the battery reaches 5% of its capacity. Any extra energy is put to use to recharge the battery. This procedure continues until the battery is fully recharged or until the power system is available to recharge it. The consumption region receives power directly from the power system or battery during this period. The battery unit automatically disconnects from the system after it has finished charging and stays disconnected till the micro grid sends another "island mode" request to the battery unit.

The power grid continues to receive electricity produced by the wind turbines, as shown in Figure 1. The micro grid's operational cycle ends with this case. The consumer in the aforementioned situations did not experience a blackout or a decline in power quality.

4. System Development

Establishing a simulation of a wind power plant before building a real one is essential, as it enables testing and design optimization in a virtual environment. The behavior of the wind power plant may be reliably predicted using simulation models, which can also be used to find possible issues and enhance the plant's overall performance.

Simulations can save time and resources by spotting design issues before construction starts because building and operating a real wind farm can be expensive and time-consuming.

Additionally, simulations can be used to assess how the wind farm would affect the surrounding area's environment and communities, including how it will affect animals, noise levels, and visual effects. Having a wind power facility that is both economically and environmentally sustainable can be ensured thanks to this.

4.1. Micro Grid Controller

The micro grid controller is the key element in dealing with the plant, grid, state charge, and battery storage system, as seen in Figure 2.

By controlling the functioning of the grid, which consists of wind turbines, battery storage devices and other distributed energy resources, the micro grid controller plays a crucial part in the simulation of wind power plants. The controller uses information from detectors and additional observation tools to optimize the functioning of the micro grid by regulating the output of the wind turbines and balancing energy's demand and availability inside the micro grid. This may entail managing the energy storage devices' charging and discharging processes, controlling the frequency and voltage of the electrical output from the wind turbines, coordinating the operation of several wind turbines, and so forth.

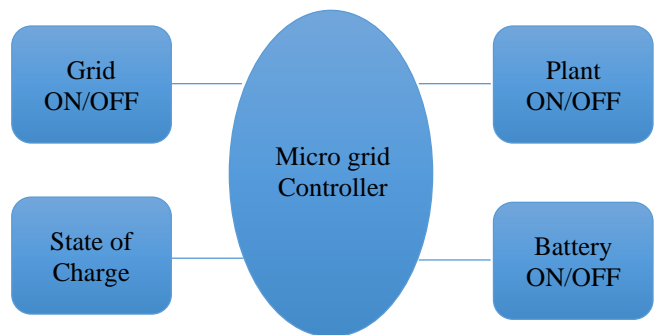

Fig. 2 Block diagram of micro grid controller

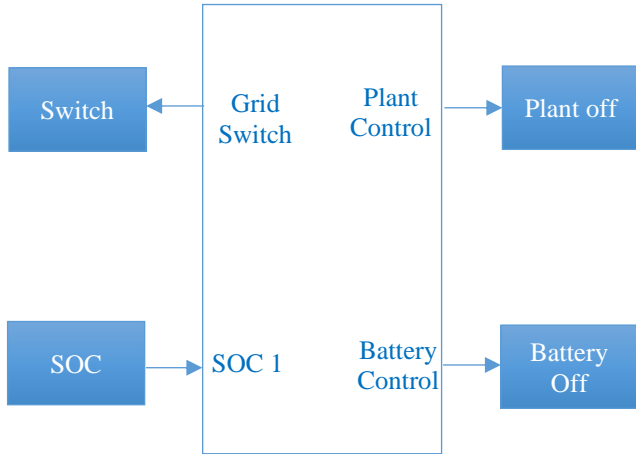

Fig. 3 Micro grid controller

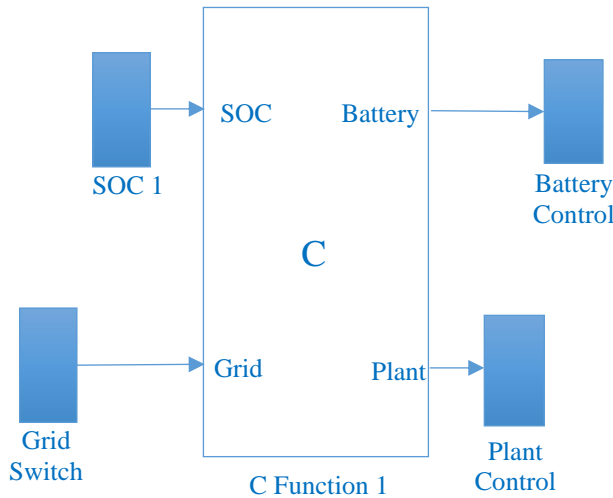

Fig. 4 Internal structure of micro grid controller

The micro grid controller can integrate other clean energy options, such as photovoltaic power or hydrogen cells, in the micro grid, as depicted in Figure 3.

The controller can help wind power plants produce as much energy as possible, reducing costs and the facility's negative effects on the environment by optimizing the operation of micro grids. Figure 4 shows the internal structure of the grid.

4.2. Step-Up Transformer

As it is employed to increase the potential of the electrical output from wind turbines before it is sent into the grid, the step-up transformer is a crucial part of wind power plant modeling.

The step-up transformer raises the potential of the electrical output to a limit appropriate for transmitting around the electrical grid by connecting to the wind turbine generator's output. As a result, there is little loss of power

owing to resistance in the transmission lines when the electrical power generated by the wind turbines is carried over large distances.

The step-up transformer can also act as an isolation device between the generator of a wind turbine and the electrical grid, enhancing the safety and dependability of the wind power plant.

The step-up transformer is frequently modeled in wind power plant modeling using software that replicates the performance of the transformer in different operation conditions. This enables engineers and designers to test the transformer's performance with different demand scenarios and voltage ranges and optimize the transformer's design for optimal efficiency and dependability.

4.3. Load (Consumption Site)

As it represents the electrical demand or consumption of the local grid or a specific place receiving energy from the wind power plant, the load, also known as the consumption site, is a crucial element in the simulation of wind power plants.

The load in this wind power plant simulation is often modeled as an electrical load or a group of electrical loads that reflect the numerous electrically consuming devices or appliances shown in Figure 5. The electricity demand can be modeled as a variable load, where it changes over time, or as a constant load, where a certain number of businesses or appliances continuously consume electricity.

Due to its impact on both the steadiness of the electrical system and the operation of the wind turbines, the load is a very critical factor for simulation. The voltage and frequency of the outcome from the wind turbines may decrease if the load is too great, which may lead to instability and damage to the wind turbines or the electrical grid. On the other hand, if the load is too low, this can result in instability and damage by raising the voltage and frequency.

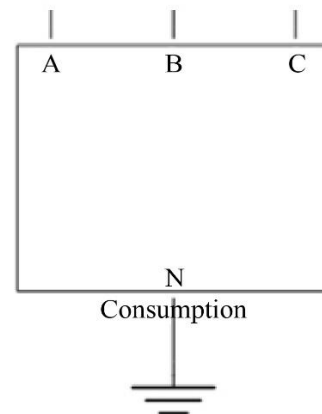

Fig. 5 Load (consumption site)

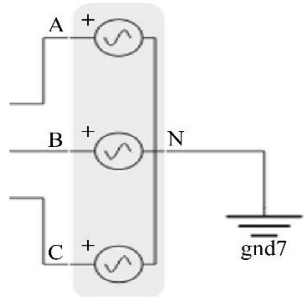

Fig. 6 Transmission line substation

Engineers and designers may evaluate the behavior of wind turbines and grids under various load scenarios by simulating the load, and they can then optimize the architecture of the wind farm for optimal efficiency and stability. Additionally, they may examine the impact on the execution of the wind power plant by adding or deleting electrical loads or altering the pattern of load consumption.

4.4. Transmission Line Substation

The Transmission Line Substation shown in Figure 6 is an important component in wind power plant simulation, as it connects the electrical output from wind turbines to the leading electrical system. Due to the low voltage at which the electrical output from wind turbines is normally produced, it cannot be transmitted across long distances. As a result, the step-up transformer receives the electrical output from the wind turbines first and raises the voltage to the limit advised for long-distance transmission. The transmission line substation receives the electrical output after the potential is boosted.

The step-up transformer's high-voltage electrical output must be changed to the proper voltage and frequency for the main electrical grid at the Transmission Line Substation. In order to guarantee a steady and dependable electrical supply for the consumers, the substation also ensures that the electrical outcome from the wind farm is synchronized with the electrical output from other power plants on the grid. The Transmission Line Substation is generally modeled in wind power plant modeling using software that mimics the substation's behavior under various operating situations. This enables engineers and designers to test the substation's behavior under various load scenarios and voltage levels and to optimize the substation's architecture for optimal efficiency and dependability. Additionally, it is beneficial to assess how the wind power plant will affect the primary electrical grid and to confirm that it complies with all applicable rules and guidelines for the electrical grid.

4.5. Underground Cable System

Since it is in charge of transferring the electrical output from the wind power plant to the primary electric system the Underground Cable System shown in Figure 7 is a crucial part of wind power plant simulation.

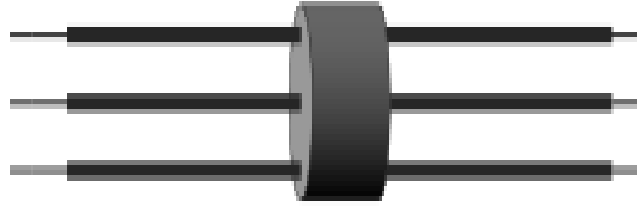

Fig. 7 Underground cable system in the plant

The wind turbines' electrical output is typically produced at low voltage and high current. The electrical output is transferred via an underground cable network to the Transmission Line Substation, where it is transformed to the proper voltage and frequencies needed by the main electrical grid after being raised in voltage using the step-up transformer.

The stability and effectiveness of the wind power plant and the primary electrical grid might be impacted by the subterranean cable system, so it is crucial to simulate it accurately in wind power plant simulation. Engineers and designers can assess the effect of the cable system on the functioning of wind power plants by simulating the behavior of the underground cable system. They can then optimize the design for optimal performance and reliability.

4.6. Step-Down Transformer

Usage of the step-down transformer in a wind micro grid is essential for converting the high voltage produced by the wind turbines into a minimum voltage appropriate for distribution and consumption within the micro grid. It enables efficient and safe utilization of wind-generated electricity, contributing to the reliable and sustainable operation of the micro grid system. Wind turbines produce electricity at a relatively high voltage, typically in the range of thousands of volts.

However, this high voltage is unsuitable for most applications and cannot be directly utilized by the micro grid's homes, businesses, or other electrical devices. Therefore, a step-down transformer is employed to reduce the voltage to a limit compatible with the local distribution system.

By adjusting the ratio of the turns of windings in the transformer, the voltage is reduced to the appropriate limit for safe and efficient distribution within the micro grid. The transformed electricity can then be transmitted over shorter distances with reduced losses and utilized by the consumers or stored in energy storage systems for later use. The step-down transformer in a wind power plant is also modeled using software to replicate its behavior under different operating conditions. This modeling enables engineers and designers to analyze and assess the performance of the step-down transformer in various load scenarios and voltage ranges.

4.7. Battery Inverter and the Battery

Incorporating a battery inverter and battery system allows for the modeling and analysis various operational scenarios and control strategies. Simulation software can simulate the charging and discharging behavior of the batteries, considering factors such as the state of charge, efficiency losses, and battery degradation over time.

By incorporating the battery inverter and battery system in wind micro grid simulation, engineers can evaluate the impact of energy storage on the micro grid's renewable energy integration, grid stability, and overall system performance.

It helps in optimizing the sizing and operation of the battery system, considering factors such as wind power variability, load profiles, and economic considerations.

The battery inverter also plays a crucial role in providing grid-supporting operations, including voltage management and frequency regulation. It may react swiftly to changes in voltage or frequency inside the network, collecting or pumping power as necessary to keep the grid stable. This capability enhances the overall performance and reliability of the micro grid system.

In summary, using a battery inverter and battery system in wind micro grid simulation enables the modeling, analysis, and optimization of energy storage integration. It enhances the utilization of wind power, provides grid support functions, and improves the total dependability and effectiveness of the micro grid system.

4.8. Summation Site

Using a summation site in wind micro grid simulation enables the aggregation, monitoring, and control of power output from individual wind turbines or DERs. It provides valuable insights into the micro grid's overall power generation and performance, facilitating effective management, control, and optimization of renewable energy resources within the system.

The summation site acts as a data collection and aggregation point, receiving real-time or periodic power output measurements from each wind turbine or DER connected to the micro grid. This information is essential for system operators and engineers to monitor and analyze the overall performance of the micro grid's renewable energy generation.

In wind micro grid simulation, a summation site is crucial in aggregating the power output from multiple wind turbines or Distributed Energy Resources (DERs) within the micro grid. It serves as a central point where the power generation data from individual sources is collected and combined to provide an overall representation of the micro grid's power generation.



Fig. 8 Fault & repair buttons

4.9. Fault Simulation

In this simulation, we have used the simulation button. This button gives us the drop-down menu to assign the values or properties of the quantities we want to simulate.

Also, there is a feature of this simulation button that this button can be assigned with fault duration, i.e., the time period for which we want to simulate the fault. Here, while using this simulation button, we can assign it to the faults in the wind micro grid. We can assign the different types of faults or values of over voltages, over-currents, voltage dip, current fall, etc., to simulate those instances. Also, one can assign this button to simulate faults like short circuit faults, arc faults, etc. Here, in this micro grid, the key is used as the simulation button to simulate an overcurrent type of fault. In this type of fault, the voltage is dipped than its rated value at which the voltage is supposed to be maintained, which results in a tremendous rise in the current rating. This can happen because of a short circuit, arc fault or ground fault, failure of any component, incorrect design, excessive load, etc. While running this model in the HIL SCADA panel, we just need to click the fault button when the micro grid is already in working or generation mode. The results of the fault can be seen in the scope, as shown in Figure 8, which is used for system monitoring, such as observing overall voltage and current and the battery measurements.

5. Result and Discussion

Supervisory Control and Data Acquisition is a computer-based control system that collects and analyzes real-time data, allowing operators to monitor and manage complex systems efficiently. In a typical mode of operation shown in Figure 9, the wind farm generates electricity when the battery is fully charged (100%), and the energy produced is delivered to the power system while the consumer is powered by the power system itself.

This research investigates a rule-based battery control strategy designed to maximize wind power utilization and minimize curtailment. The strategy prioritizes supplying the load directly from wind turbines. In this case, a Battery Discharge Threshold (BDT) is defined as a 5% State of Charge (SOC). When the battery SOC reaches the BDT, a relay or a power electronic converter is triggered, as shown in Figure 10. To divert wind turbine output from supplying the load directly to charging the battery. This charging continues until the battery reaches its Full Charge Threshold (FCT), typically 100% SOC, or until an external signal indicates grid power availability for charging (if applicable).

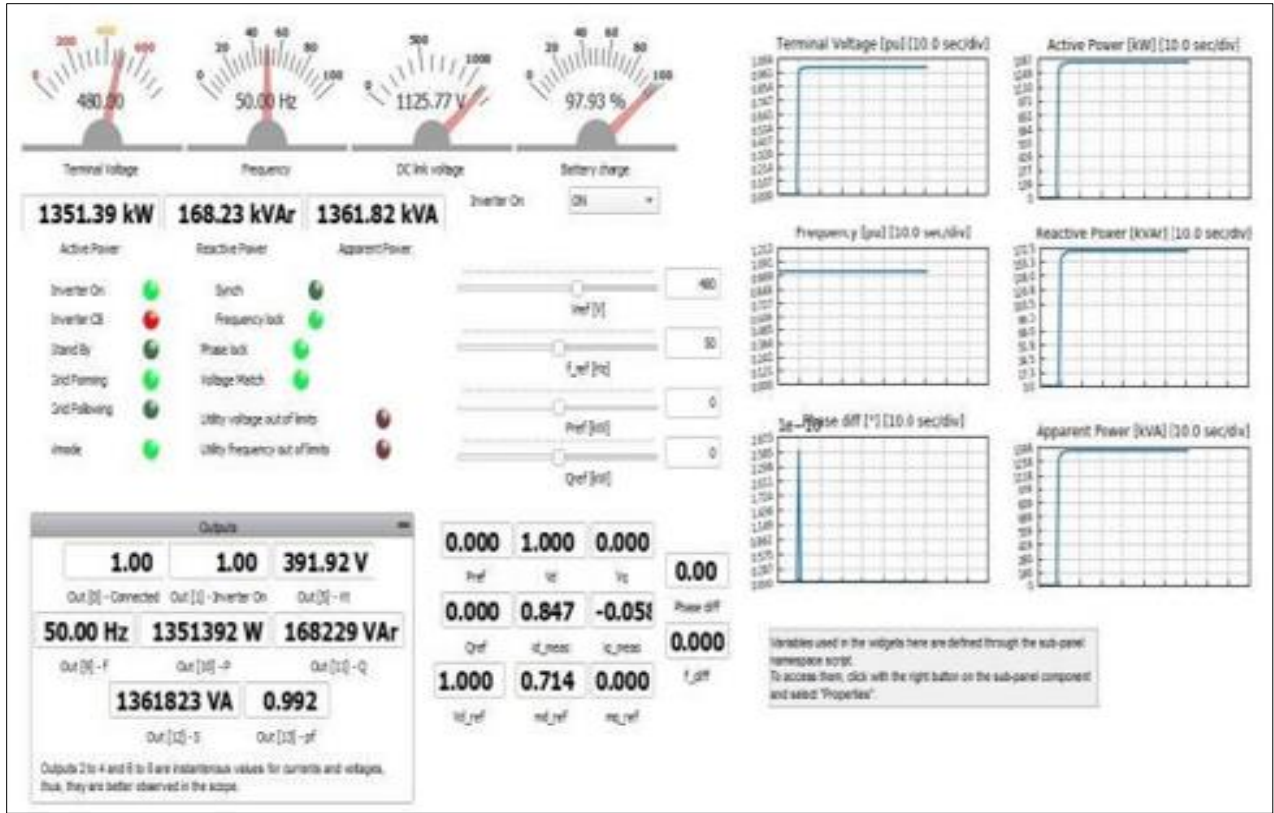

Fig. 9 SCADA system for the battery unit when constructing the micro grid

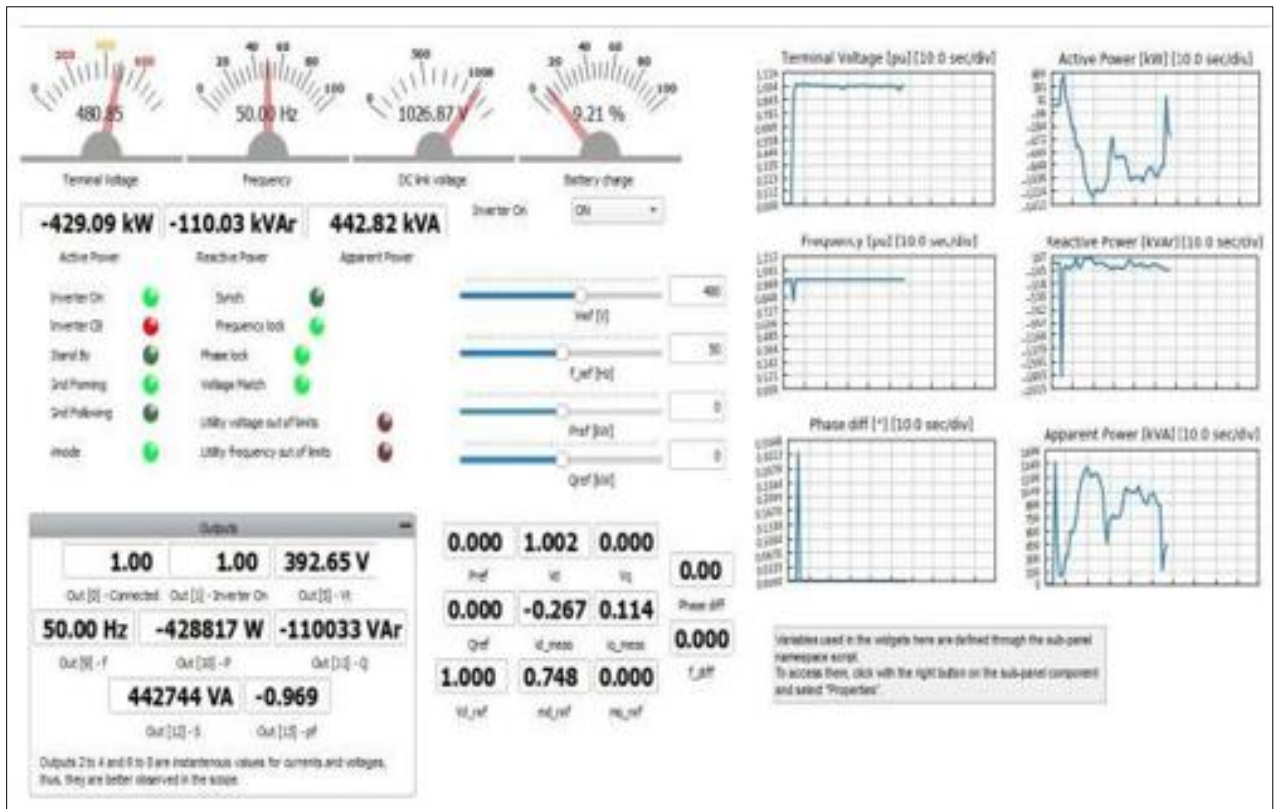

Fig. 10 Operating mode when a wind farm is connected to the micro grid and the battery unit capacity reaches 5%

Wind speed data is retrieved from a text file named "WindSpeed.txt", located within the model's directory. This file is assumed to be a plain text file containing time-series wind speed values. Generator start-up efficiency and grid stability hinge on a critical relationship: voltage and power. By implementing adaptive control strategies that manage voltage fluctuations during this crucial phase, one can ensure optimal power output from the wind generator while contributing to a reliable and stable grid.

A fault triggered a voltage drop below 95% of nominal, prompting the undervoltage relay to automatically switch the micro grid to island mode, ensuring its continued operation independent of the main grid. A fault event resulted in a voltage sag exceeding a predefined threshold (95% of nominal voltage). This triggered the activation of the undervoltage relay, a protective device crucial for islanding. Islanding refers to the automatic disconnection of a distributed generation system (like the micro grid) from the main grid in response to a fault or abnormal operating condition. By initiating islanding, the relay ensured the micro grid's continued operation in an isolated mode, independent of the main grid's voltage instability.

These diagrams from Figures 11 to 15 visually represent how voltage fluctuations within a consumption area impact both active and reactive power production. Analyzing this critical interaction between voltage and power allows us to identify control strategies and system improvements that

optimize grid stability and ensure reliable energy delivery to consumers.

Following fault resolution, the micro grid underwent a successful resynchronization process, seamlessly transitioning from island mode back to grid-connected operation.

This automated procedure minimized service interruptions for critical loads and optimized overall system efficiency by leveraging the combined resources of the micro grid and the main electrical grid.

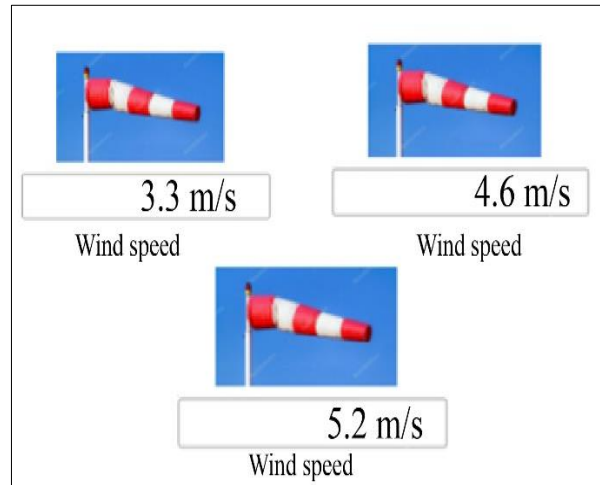

Fig. 11 Variable wind speed

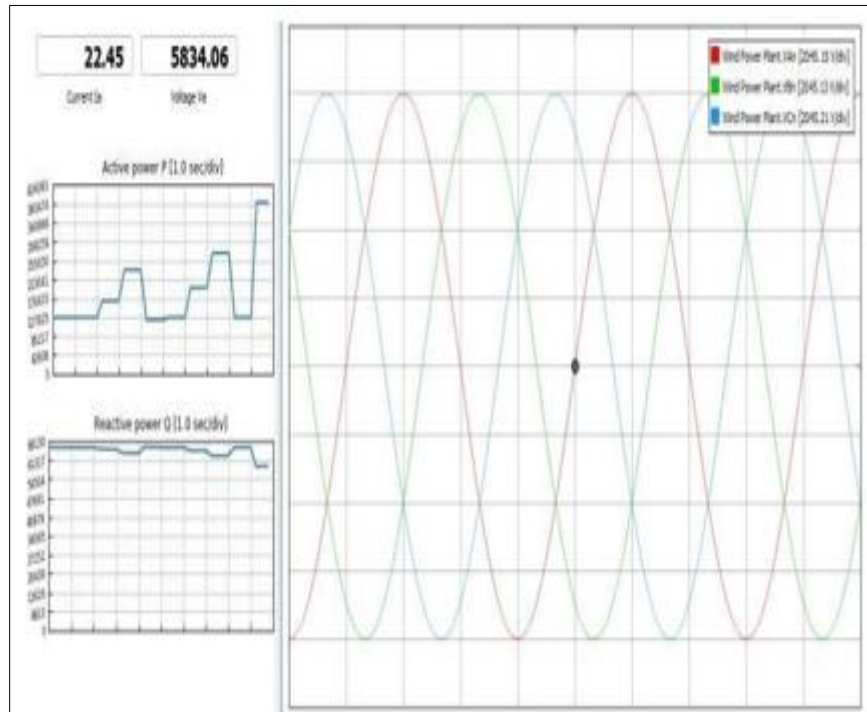

Fig. 12 Production of active and reactive power under various voltage situations for wind generators (when the wind is passed, i.e. when we start the system)

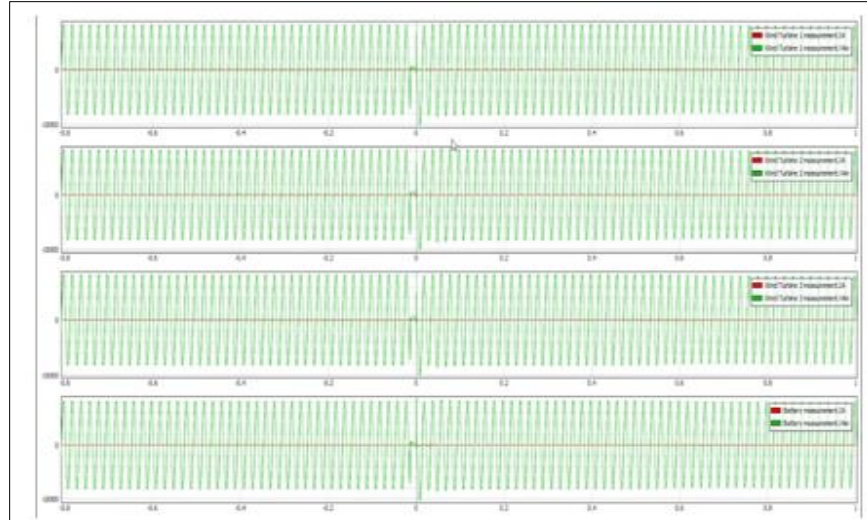

Fig. 13 System voltage falls below 95% V_n due to a fault. Island mode (stand alone or separated) is automatically selected for the micro grid by an under voltage relay that detects the error

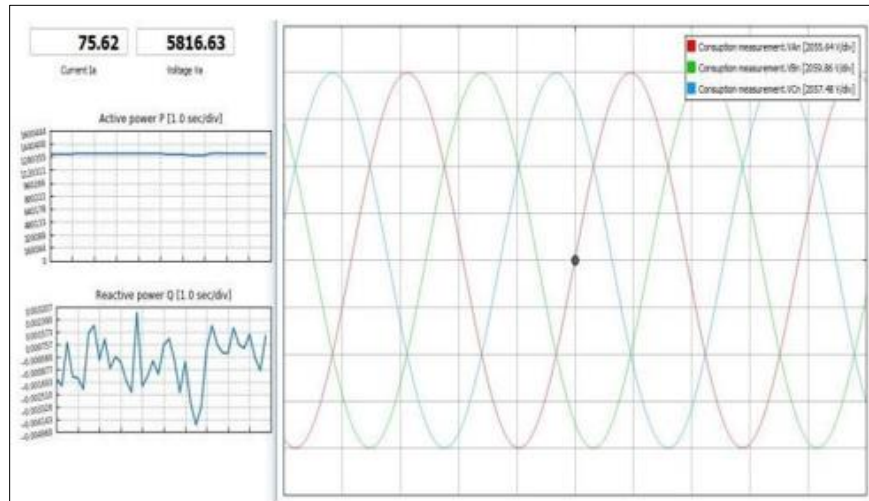

Fig. 14 Active and reactive power production showing the voltage circumstances in the consumption area

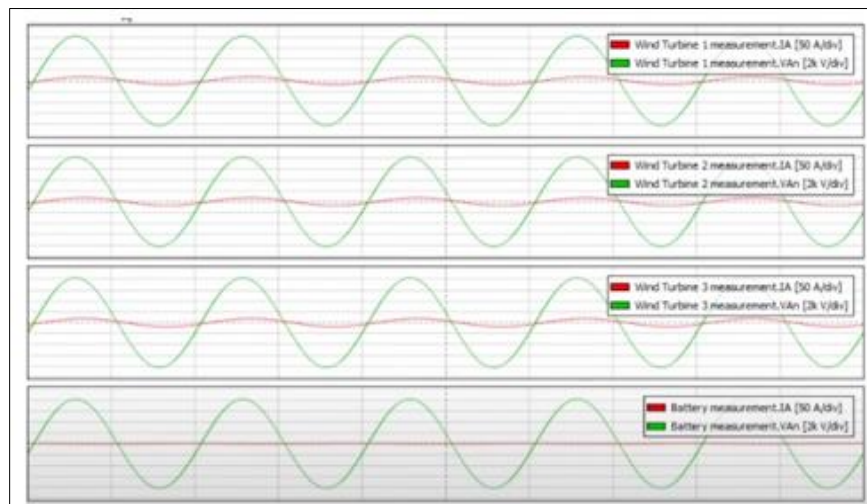

Fig. 15 Micro grid automatic connection after fault fixed

6. Conclusion

This research investigated the integration of wind power with battery storage and transmission line management, exploring their impact on system performance. We developed a simulation model to evaluate different system configurations' effectiveness in minimizing energy curtailment, enhancing grid stability, and maximizing overall system efficiency.

Our key findings highlight battery storage's crucial role in addressing wind power's intermittency. By storing excess energy and releasing it strategically, curtailment is reduced, grid stability improves, and overall wind power utilization is enhanced. Additionally, optimizing transmission line capacity is essential for efficiently delivering wind-generated electricity, minimizing transmission losses, and facilitating large-scale wind project integration.

6.1. Future Scope

While this research provides valuable insights for identifying optimal configurations in various scenarios, it is essential to acknowledge limitations. Validating the simulation results with real-world data from operational wind farms would further strengthen the credibility of our findings.

This would involve comparing model outputs with actual system behavior under different operating conditions.

Furthermore, a more comprehensive understanding of system dynamics can be achieved by exploring the synergies and challenges of integrating battery storage with other renewable energy sources, such as solar power. Analyzing how these renewable sources can complement each other and the potential challenges of their combined management would be valuable for future research.

Moving forward, several exciting research directions warrant further exploration. Investigating the impact of advanced control strategies on system performance holds immense potential for optimization. Additionally, developing more sophisticated models capable of accounting for the dynamic behavior of wind power systems combined with other renewables will be crucial for future advancements. Finally, studies into the economic feasibility of different system configurations are essential to ensure that wind power remains a cost-effective and sustainable energy solution. By addressing these research challenges, we can continue to revolutionize the development of wind energy solutions and contribute to a cleaner and more sustainable future.

References

- [1] Bin Li, Xinmei Mo, and Biyun Chen, "Direct Control Strategy of Real-Time Tracking Power Generation Plan for Wind Power and Battery Energy Storage Combined System," *IEEE Access*, vol. 7, pp. 147169-147178, 2019. [[CrossRef](#)] [[Google Scholar](#)] [[Publisher Link](#)]
- [2] Jintao Cui et al., "Distributed Energy Storage System in Wind Power Generation," *2011 4th International Conference on Electric Utility Deregulation and Restructuring and Power Technologies*, Weihai, China, pp. 1535-1540, 2011. [[CrossRef](#)] [[Google Scholar](#)] [[Publisher Link](#)]
- [3] Wei Xian et al., "Minimize Frequency Fluctuations of Isolated Power System with Wind Farm by Using Superconducting Magnetic Energy Storage," *2009 International Conference on Power Electronics and Drive Systems*, Taipei, Taiwan, pp. 1329-1332, 2009. [[CrossRef](#)] [[Google Scholar](#)] [[Publisher Link](#)]
- [4] Ende Hu et al., "Research on Capacity Optimization of Offshore Wind Power Flow Combined Power Generation System Based on Homer," *2020 IEEE 4th Conference on Energy Internet and Energy System Integration (EI2)*, Wuhan, China, pp. 2684-2689, 2020. [[CrossRef](#)] [[Google Scholar](#)] [[Publisher Link](#)]
- [5] Iman Naziri Moghaddam, and Badrul Chowdhury, "Optimal Sizing of Hybrid Energy Storage Systems to Mitigate Wind Power Fluctuations," *2016 IEEE Power and Energy Society General Meeting*, Boston, USA, pp. 1-5, 2016. [[CrossRef](#)] [[Google Scholar](#)] [[Publisher Link](#)]
- [6] Tianmeng Yang, "The Optimal Capacity Determination Method of Energy Storage System with Different Applications in Wind Farm," *2016 IEEE PES Asia-Pacific Power and Energy Engineering Conference*, Xi'an, China, pp. 2081-2085, 2016. [[CrossRef](#)] [[Google Scholar](#)] [[Publisher Link](#)]
- [7] M. Saber Eltohamy et al., "Analyzing Wind Power Ramps for High Penetration of Variable Renewable Generation," *2019 21st International Middle East Power Systems Conference (MEPCON)*, Cairo, Egypt, pp. 768-775, 2019. [[CrossRef](#)] [[Google Scholar](#)] [[Publisher Link](#)]
- [8] Ziyu Fang, and Jonathan K.H. Shek, "Design and Optimization of a Hybrid Renewable Energy System for Weizhou Island," *2023 58th International Universities Power Engineering Conference (UPEC)*, Dublin, Ireland, pp. 1-6, 2023. [[CrossRef](#)] [[Google Scholar](#)] [[Publisher Link](#)]
- [9] Evaggelos Tsioumas et al., "Energy Management and Power Control Strategy at the Low Wind Speed Region of a Wind Generation Microgrid," *IECON 2016 - 42nd Annual Conference of the IEEE Industrial Electronics Society*, Florence, Italy, pp. 4097-4102, 2016. [[CrossRef](#)] [[Google Scholar](#)] [[Publisher Link](#)]

- [10] A. Ellis et al., "Generic Models for Simulation of Wind Power Plants in Bulk System Planning Studies," *2011 IEEE Power and Energy Society General Meeting*, Detroit, MI, USA, pp. 1-8, 2011. [[CrossRef](#)] [[Google Scholar](#)] [[Publisher Link](#)]
- [11] Yuhan Guo et al., "Small-Signal Stability Modeling and Analysis of Power System with Integrated Photovoltaic Energy Storage," *IEEE 6th Conference on Energy Internet and Energy System Integration (EI2)*, Chengdu, China, pp. 2850-2856, 2022. [[CrossRef](#)] [[Google Scholar](#)] [[Publisher Link](#)]