

## Design, Analysis & Fabrication of Efficycle: A Hybrid Tricycle

Prof. S. U. Gunjal<sup>#1</sup>, Prof. G. D. Sonawane<sup>#2</sup>, Prof. S. P. Awate<sup>#3</sup>, Prof. D. R. Satpute<sup>#4</sup>

<sup>#</sup>Assistant Professor, Department of Mechanical Engineering  
Sandip Foundation's - SITRC, Mahirawani, Nashik 422213  
Savitribai Phule Pune University, Pune, Maharashtra, India.

**Abstract**— There is increasing concern over congestion and pollution associated with the use of motor vehicle for personal transport. This project aims to design a vehicle that could be viable alternative to cars for short distance journeys. The designed vehicle is an Ultra Light Vehicle. It is powered by a hybrid human-electric drive system. The vehicle design adopts off-the-shelf bicycle and electric vehicle technology which work together to create a lightweight vehicle.

A concept frame was devised for investigation for the project. It incorporates straight-ahead position that has theoretical safety benefits, while at the same time remaining simple in its design. The frame design consists of just two members which make manufacturing easy. A preliminary study into this frame's structural integrity has been completed. The vehicle can seat two adults, each of whom could power it via foot pedaling. A mechanical drive system – which on its own could power the vehicle – has also been designed, as has an electrical drive system that can be retrofitted at the rear side.

**Keywords**—Efficycle, pollution, ultra light, hybrid, mechanical drive.

### I. INTRODUCTION

The initiative towards EFFICYCLE was taken with aim to have hands on experience in designing a Hybrid Human-Electric cycle keeping in view the ease of manufacturing and economy. The design was made by the use of modeling software PRO-E WILDFIRE 4, and design was analyzed by FEM analysis software ANSYS 12.0. Simplicity of design and Hybrid drive train were the key parameters in the vehicle design.

### II. BASIC DESIGN PROCEDURE

Care was taken to accurately define the goals and constrains of the project before we engineer the solution to meet these goals. The basic design procedure followed is as below.

#### A. Assumptions

Here basically considering the constrains of dimensions we first of all assumed the dimensions of the vehicle.

#### B. Ergonomics

After assuming the dimensions our main area of interest was to make the vehicle ergonomic for an average adult person.

#### C. Design

Here we actually designed the vehicle in modeling software PRO-E WILDFIRE 4.

#### D. Analysis

The analysis of the design was carried out by FEM analysis software ANSYS 12.0 in order to ensure that the designed vehicle is safe.

#### E. Modification in design

Based on the results obtained from analysis modifications were done in the existing design.

#### F. Analysis

Again the analysis was done of the modified design and it was found to be safe.

#### G. Manufacturing

During manufacturing various parameters like serviceability, craftsmanship and cost reduction were considered.

#### H. Aesthetics

In order to make the vehicle more attractive and convincing its aesthetic considerations like appearance were given at most importance.

### III. VEHICLE SPECIFICATIONS AND DIMENSIONS [1]

- Motor: PMDC 1500 rpm & 48 Volts motor,
- Frame material: Aluminum Alloy 6061 T6,
- Weight of driver: 115 kg each,
- Wheel configuration: Front-1 Rear-2,
- Steering: Articulated Steering,
- Turning Radius: 3.3m with 45 degree turning angle,
- Braking: Front-Conventional & Rear-Disc,
- Max. Length: 2270mm,
- Height 800mm,
- Wheel base: 940 mm,
- Ground clearance: 320 mm.

### IV. 3D VIEWS OF THE COMPLETE VEHICLE

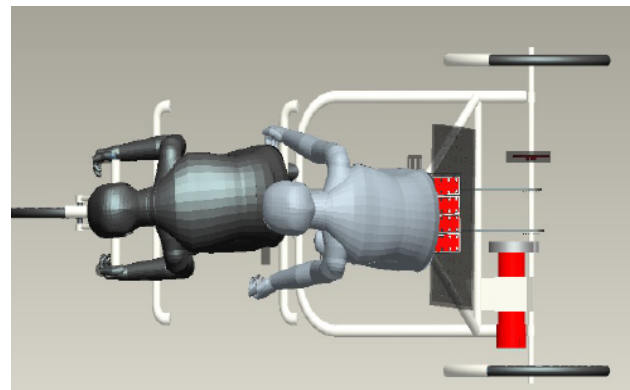

A. Top View

B. Front View

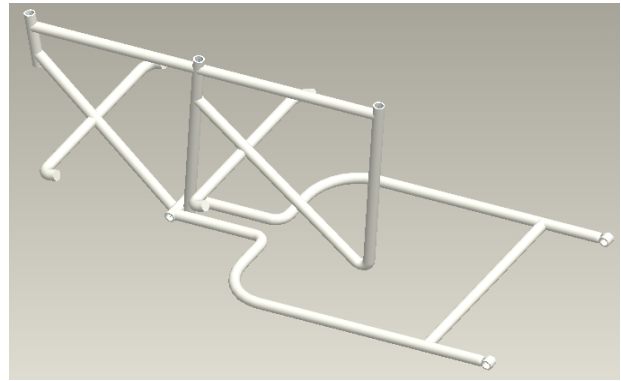
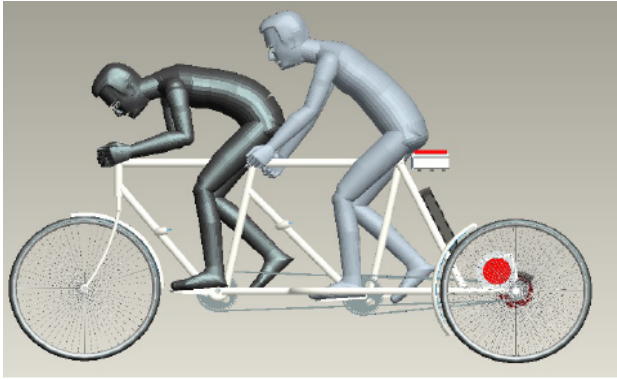
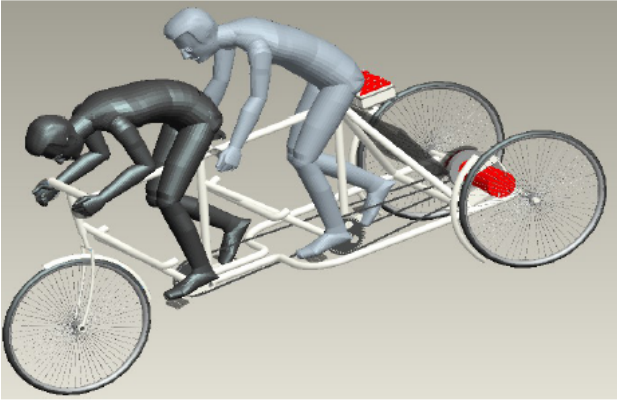

Fig. 1 View of space frame

C. Isometric View



Weight of roll cage= 16 kg (approx).

C. Material used

The commonly used material for tubing is Aluminum Alloy T6 [2]. The frame will be built using MIG welding [2].

Material properties:

OD: 35 mm

ID: 25 mm

Density: 2700 kg/cm<sup>3</sup>.

VI. ANALYSIS

The analysis is done in the FEM analysis software ANSYS 12.0. The conditions are given below

A. Structural Analysis

Considering maximum weight of one driver as 115 kg/1128 N forces were applied on driver's sitting position in downward direction. Also a load of 200 N was applied at peddles of both drivers.

V. roll cage design and driver ergonomics

A. Driver Ergonomics [1]

This includes factors as follows

- Place of seat, steering handle
- All levers, switches should be in reach of driver's hand
- Sufficient Leg room, head room for both the drivers.

B. Placement of The Aggregates

- PMDC motor and gear assembly is at rear of driver.
- Battery and maneuverability basket is at the rear side of both the drivers
- Scratch guards are provided on both the sides of driver to prevent injuries in case of an accident.

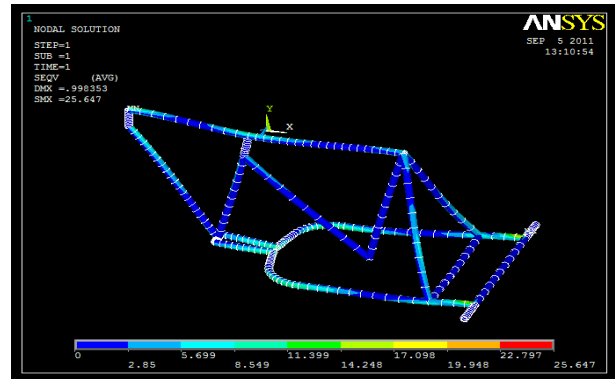

Fig. 2 Static analysis

RESULTS:

Deflection: 0.9983 mm

Von misses stress: 25.647 N/mm<sup>2</sup>

**B. Shock Analysis**

Now we analyzed the stresses on the vehicle caused by a 3 G load on it. This is equivalent to a loading force of 6900N on single front wheel. The resulting stresses from this loading are seen in Figures. After reviewing the results of the finite element analysis is evident that the stresses are well within yield strength of material

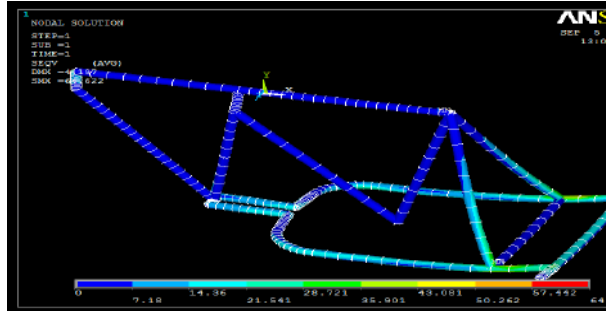

Fig. 3 Static analysis

**RESULTS:**

Force: 3G

Deflection: 4.197mm

Von misses stress: 64.622 N/mm<sup>2</sup>

**C. Rollover Impact Analysis**

Finally we analyzed the stress on the space frame caused by a rollover with a 2 G load on the cage. This is equivalent to a loading force of 5000 N. The load is chosen to be on a single corner as this would be a worst case scenario rollover. After the addition of the support in FBM, another analysis is run using identical parameters. The addition of this top bracing member, showed no appreciable changed in the stress of the frame.

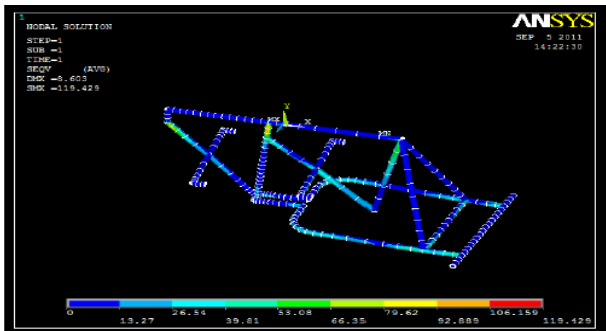

Fig. 4 Roll over impact analysis

**RESULTS:**

Force: 2G

Deflection: 8.603mm

Von misses stress: 119.429 N/mm<sup>2</sup>

Yield strength (Syt) of Aluminum Alloy T6= 275 Mpa

As  $S_{yt} > \sigma_{von}$ . The design is safe.

**D. Braking Calculations** [3, 4, 5, 6]

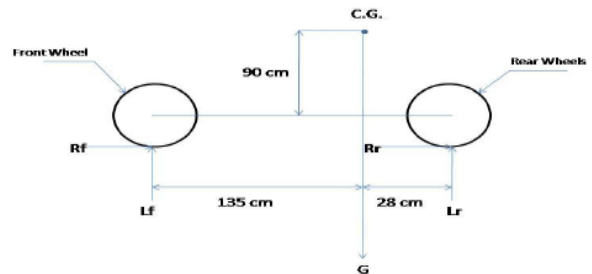

Fig. 5 Forces involved in braking

Assuming a vehicle at max. Speed of 40kmph will stop covering a distance of 10m.

Equation of motion

$$V^2 = u^2 + 2as$$

$$\text{so, } a = \frac{V^2 - u^2}{2s}$$

$$a = \frac{0^2 - (40 \cdot 1000 / 3600)^2}{2 \cdot 10}$$

$$a = 6.1727 \text{ m/s}^2 \text{ (Retardation)}$$

$$\text{Retarding Force} = \text{mass} \cdot a = 270 \cdot 6.1727 = 1666.63 \text{ N}$$

**PART-1**

$L_f, L_r$  = Reactions on respective wheel

**In static condition,**

$$L_f + L_r = 2648.7 \text{ -----(1)}$$

$$\sum M_{c.g.} = 0$$

$$L_f \cdot 1350 = L_r \cdot 280 \text{ -----(2)}$$

From equation 1 & 2

$$L_f = 2193.70 \text{ N and } L_r = 455 \text{ N}$$

**In dynamic condition,**

$$\sum M_{c.g.} = 0$$

$$L_f \cdot 1350 - 1666.63 \cdot 900 - L_r \cdot 280 = 0 \text{ -----(3)}$$

From equation 1 & 3,

$$L_f = 1273.483 \text{ N and } L_r = 1375.217 \text{ N}$$

Then,

**Torque for single front wheel** [5],

$$T_f = (1375.217 / 9.81) \cdot 6.1727 \cdot 0.32 = 270.90 \text{ N-m}$$

C.G. height,  $h = 90 \text{ cm} = 900 \text{ mm}$

**Similarly,torque for single rear wheel,**

$$T_r=(1273.483/9.81*2)*6.1727*0.32=128.2N\text{-m}$$

**Total Torque,**

$$T=276.90+2*128.2=533.318N\text{-m}$$

**PART-2**

The leverage=15:2=7.5

Master Cylinder O.D.=15.96mm

So, Pressure obtained is,

$$P=63*7.5/0.7854*(0.01596)^2=2.362*10^6N/m^2$$

Where, **63N force is required by rider** for braking to stop vehicle which is calculated by trial and error method for the required value of applied torque. So,

**Torque applied,**

$$T=2*p*A*\mu*Rf*n$$

$$T=2*2.362*10^6*0.7854*0.0452*0.32*0.080*3$$

$$T=540.90N\text{-m}$$

**Results,**

The required torque is **533.318N-m**

The applied torque will be **540.90N-m**

Hence, it will be enough to stop the vehicle.

**VII. DESCRIPTION OF DRIVE TRAIN [1]**

Drive train is the most important parameter for power transmission for any vehicle. Here we are using chain drive as a power transmission device. The pictorial view of how transmission is given to the rear wheels is shown below. Both the driver’s chain wheels are connected to the rear axle through respective freewheels which ultimately propel the vehicle.

- Specifications of drive train:
- Roller diameter of roller=7.95mm
- Width of roller=7.85mm
- Pitch of chain=12.70mm

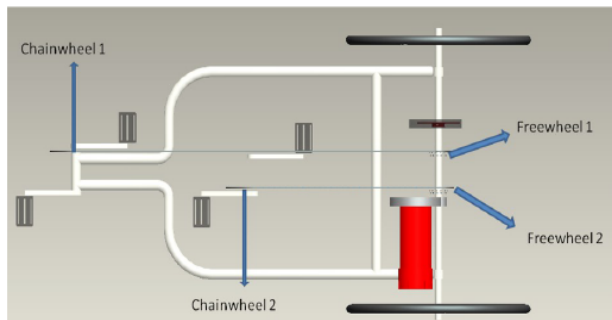

Fig. 6 The sequence of power transmission from chain wheel 1 to rear axle

**VIII. DESCRIPTION OF ELECTRICAL SYSTEM [1]**

In order to conform that our innovation (motor as a regenerative charger) is feasible we have plotted graphs by conducting various tests on the motor.

Fig. 7 shows the graph which is plotted when motor is acting as a driving unit as well as acting as a charger. When the motor will be OFF it would be continuously generating voltage that is used to charge the battery.

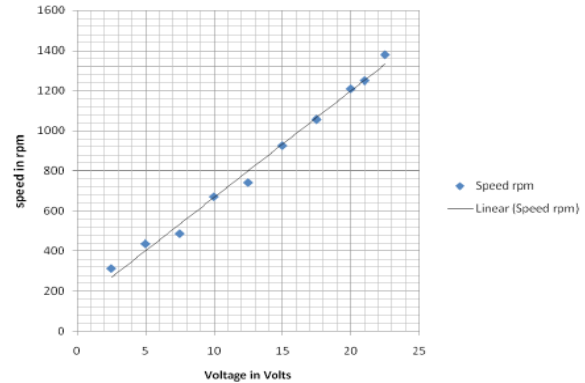

Fig. 7 Voltage vs. Speed

Similarly when the motor will be switched ON it would conduct the same charge from the battery unit.

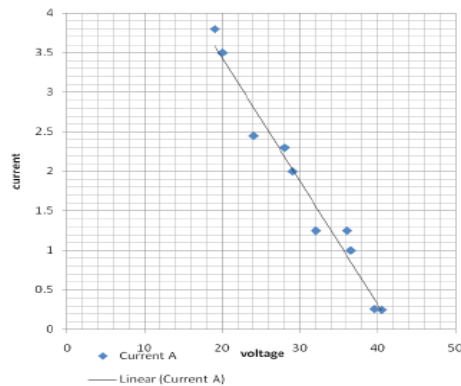

Fig. 8 Voltage vs. Current

Fig. 8 shows the graph which was plotted when motor was acting as a charger i.e it was generating charge. But instead of giving this charge to the battery, this charge was used to power electric bulbs one by one i.e load was applied on the motor.

**IX. INOVATIONS**

**A. Motor as a Regenerative Charger**

We have designed a distinct yet simple transmission system by virtue of which we can use the same motor for

driving the cycle as well as alternatively charging the battery. Due to the simplicity of concept and design of transmission system this innovation is does not involve any extra expenditure, except the cost of motor.

The chopper shown in figure 9 is type D- chopper. The operation of this chopper is two quadrant. The current direction and the voltage polarities are shown in below mentioned graph for the appropriate quadrant operation. By controlling the switches S1 and S2 we can control the voltage applied to motor and the breaking operation can be controlled. The most important part is, when motor works in second quadrant that is **regenerative braking**, we get the power from the motor to charge supply battery which is a part of our innovation.

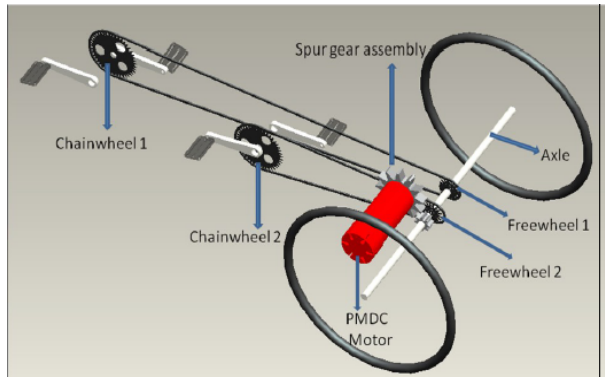

Fig. 9 Regenerative charger motor

*B. Lightest and Fastest*

The overall vehicle weight of the roll cage is 16 kilograms excluding driver’s weight due to the selection of proper material and simplicity of design. By virtue of its light weight it can attain a higher speed in minimum possible time.

*C. Rear Axle Disc Brakes*

Here we have mounted the disc brake rigidly to the rear axle just as the braking system adopted by formula racing cars. Our main aim to do so was firstly to reduce the weight of vehicle and secondly complexity of braking linkages due to the use of 2 wheels on the rear side. As only one disc brake is to be used its extremely simple to mount and control the brake.

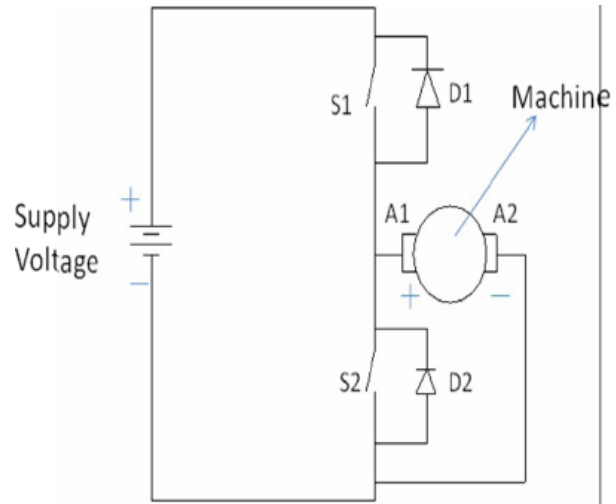
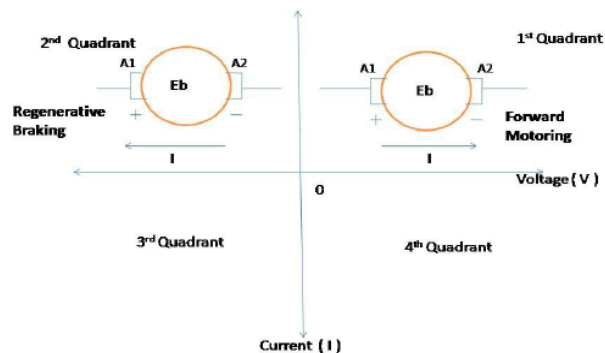

Fig. 10 Speed Control circuit of motor

**X. RESOURCES REQUIRED [2]**

*A. Fabrication shop*

- TIG & MIG welding machine.
- Pipe bending machine (hydraulic)
- Hydraulic Press
- Grinding Machine

*B. Sheet metal shop*

- Shearing Machine
- Pressing Machine
- Lathe machine

*C. Shaping machine*

- Drilling machine
- Sawing machine
- Metrology lab
- CAE/CAD/CAM lab

**XI. FEASIBILITY OF VEHICLE**

*A. Silent Features of Vehicle*

- Highly efficient Hybrid system and simplified power transmission system
- Rear disc brakes

- Lighter in weight.

*B. Field of Application*

- Can be used for charging electrical appliances
- Can be used for long journey travel
- Can be used by all age groups.

XII. UNIQUE SELLING POINT

- The hybrid system used is extremely reliable and can be used for charging battery or any other appliance.
- Ease of handling as the structure and handling is similar to that of normal bicycle.
- Disc brakes are used which are mounted directly on the axle which make it more simple and reliable even in monsoon season.
- High acceleration can be achieved due to its light weight.
- 

XIII. CONCLUSION

Pollution being the emerging issue all over the world, there should be an alternative for transport. Efficycle could be the appropriate answer for the issues regarding the same. Design & Analysis becomes easier with the use of software like ANSYS, PRO-E. etc.

REFERENCES

- [1] SAE -NIS Efficycle 2012@ rolebook
- [2] P. C. Sharma, *Production Engineering*
- [3] Khurmi Gupta, *Theory of Machine*, Third Edition
- [4] S. S. Rattan, *Theory of Machine*, Third Edition
- [5] V. B. Bhandari, *Design of Machine Elements*, Third Edition
- [6] Thomas Gillespie, *Fundamentals of Vehicle Dynamics*