

# Arm 7 Based Robotic Arm Control By Electronic Gesture Recognition Unit Using Mems

K.Brahmani<sup>#1</sup>, K.S.Roy<sup>#2</sup>, Mahaboob Ali<sup>\*3</sup>

<sup>#</sup> Dept. of ECE, K.L.University

Guntur, India

<sup>\*</sup> Vyas Informatics

Hyderabad, India

**Abstract --** Mechatronics is one of the present trends in the era of computing in today's system automation industry and control. The proposed project is one such attempt of implementing an accelerometer based system to communicate with an industrial robotic arm wirelessly. This project comprises of controlling of robotic arm powered with ARM7 based LPC1768 core. The LC1768 core has to be interfaced with DC motors of robotic arm to control the movements of robotic arm. MEMS is a three dimensional accelerometer sensor used for this purpose, this accelerometer sensor captures gestures of human-arm and produces three analog output voltages in three dimensional axes. And two flex sensors are used to control the gripper movement. For various movements of accelerometer and flex sensors corresponding characters will be sent to the ARM7 core wirelessly using 2.4GHz RF module. And depending on the received character robotic arm can be controlled in Dynamic or Static mode by communicating with EEPROM using I2C protocol.

**Keywords--** Mems, Robotic arm, Arduino, RF transceiver, Arm7, Networking.

manipulators can be easily converted through software to do a variety of tasks.

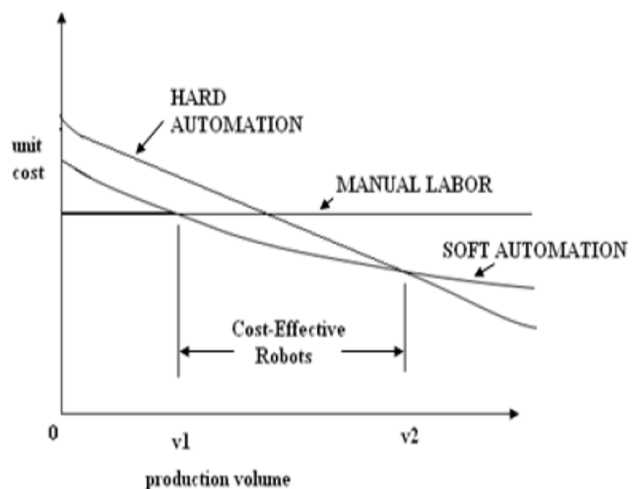

Fig: Relative cost effectiveness of soft automation

## I.INTRODUCTION

More recently, industries have introduced more flexible forms of automation in the manufacturing cycle. Programmable mechanical manipulators are now being used to perform such tasks as spot welding, spray painting, material handling, and component assembly. Since computer controlled mechanical

For very low production volumes, as those occurring in small batch processing, manual labor is the most cost-effective. With increase in production volume, there comes a point ( $v_1$ ) where

robots become more cost-effective than manual labor. With increase in production volume still further, it eventually reaches a point (v2) where hard automation surpasses both manual labor and robots in cost-effectiveness. The curve in Fig. is the representative of general qualitative trends, with the exact data dependent upon the characteristics of the unit being produced.

Robots are generally used to perform hazardous, highly repetitive, and unpleasant tasks. Most robots are set up for an operation by the teach-and-repeat technique. In this mode, a trained operator (programmer) typically uses a portable control device (a teach pendant) to teach a robot its task manually. The programming and controlling of movements of robotic arm through the use of *robot teach pendant* is still a difficult and time consuming task that requires technical expertise. Therefore, new and easier ways for robot programming are required. The main aim of this paper is to develop a methodology with a high level of abstraction that simplifies the robot programming.

In this paper we proposed an accelerometer-based gesture recognition system to control an industrial robot in a natural way. A 3-axis wireless accelerometer is attached to the human arm, capturing its behavior (gestures and postures). A trained system was used to recognize gestures and postures.

## II. BLOCK DIAGRAM

Most of the industrial robots are still programmed using the typical teaching process, through the use of the robot teach pendant. The proposed project is an mems based system to control an industrial robotic arm wirelessly using 3-axis accelerometer(mems).

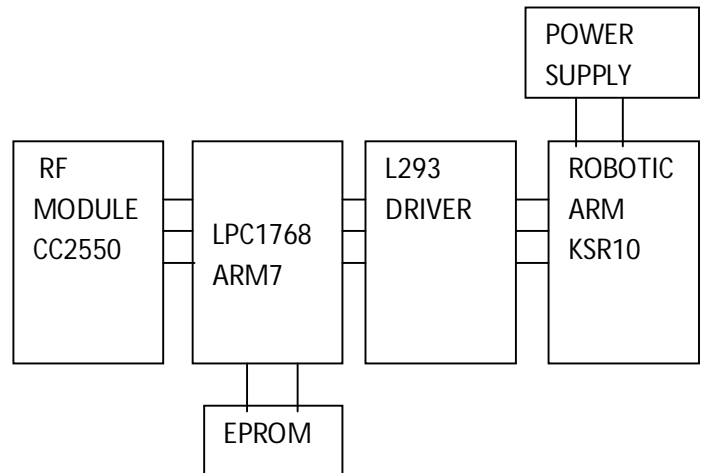
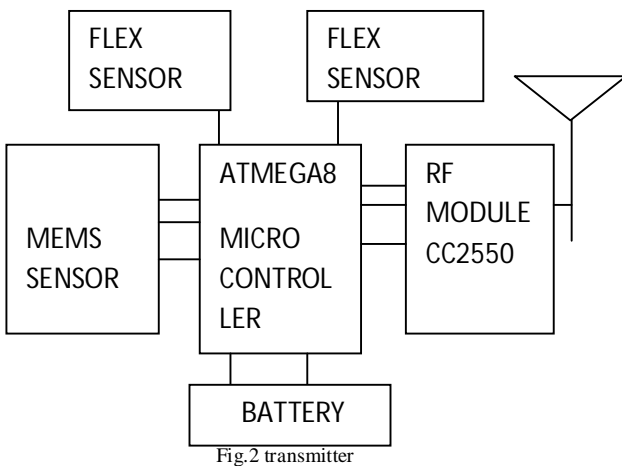

Fig.3 receiver

In the proposed project we are using KSR10 robotic arm. To control the different movements of this robotic arm and gripper, we interface motors of the robotic arm to LPC1768 ARM7 micro controller board through L293D quadruple high-current half-H motor driver board. This LPC1768 micro controller supports frequencies up to 100MHz. So, it can access the data from accelerometer with very high speed. EEPROM (24LC16B) is interfaced with the core to execute the given instructions in static mode. And to receive data from accelerometer over wireless medium we will interface a 2.4GHz RF transceiver module to LPC1768 board.

Mems board is a three axis accelerometer board . It produces three different analog voltages (x, y &z) in three dimensional motions according to the hand movement of the trainer. And we are also using two flex sensors to control the gripper movement. Flex sensors are the sensors that change resistance depending on the amount of bend on the sensor, and produces different analog voltage level. The voltages produced by accelerometer and flex sensors are converted into digital form using Analog to Digital converter. Here we are using Atmega8 micro controller, which is having in-built six channel 10-bit ADC. By configuring this in-built ADC we will convert analog signals into digital form. After interfacing accelerometer, flex sensors to atmega8 micro controller, we have to observe & analyze the digitized data in serial monitor for different positions of accelerometer and flex sensors. The converted digital data will be compared with observed values, and if the data matches then corresponding character for that movement of accelerometer will be sent to the LPC1768 micro controller wirelessly. For wireless transmission of data we are interfacing a 2.4GHz RF transceiver module to ATmega8 micro controller.

At the receiver end, received characters will be transferred to the LPC1768 Core through UART communication protocol . For each received character, there will be a pre-defined movement in the LPC1768 which will be executed either in dynamic mode or static mode depending on the select switch condition. To execute the instructions in static mode, we are communication with EEPROM using I2C Protocol . Micro controller cannot drive motors directly, hence we need to drive the motors through L293D driver circuit. Each L293D can drive maximum of two motors, therefore we need three L293D ICs to drive five motors of robotic arm.

### III ROBOTIC ARM

A robotic arm is usually programmable, with similar functions to a human arm. The links of such a manipulator are connected by joints allowing either rotational motion or translational (linear) displacement. This robotic arm includes different parameters like weight of each linkage, weight of each joint, weight of object to lift, length of each linkage, degree of freedom, work space.

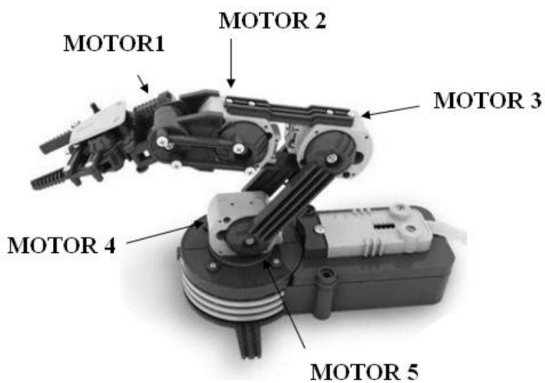

Fig.4 robotic arm

In this project we are using KSR10, a five axes robotic arm. This kit comes with all mechanical modules which are required to build the robotic arm, they are gears, links, motors, gripper, screws...etc. By using all these modules we have to assemble the robotic arm [6]. As shown in Fig. it has five DC motors, all these DC motors are interfaced with LPC1768 core through L293D driver circuit.

### IV. GESTURE RECOGNITION

Accelerometer sensor is used for gesture recognition. An accelerometer is a device that measures the vibration, or acceleration of motion and produces different voltage levels.

The force caused by vibration or a change in motion (acceleration) causes the mass which produces an electrical charge that is proportional to the force exerted upon it. Since the charge is proportional to the force, and the mass is a constant, then the charge is also proportional to the acceleration .



Fig.5. Transmitter flow chart

In this project we are using Mems which is a 3-dimensional accelerometer. This board measures acceleration in three dimensions(X, Y&Z) and produces three different voltage levels. And we are also using two flex sensors to control the gripper movement. Flex sensors are sensors that change in resistance depending on the amount of bend on the sensor. They convert the change in bend to electrical resistance - the more the bend, the more the resistance value. The output of accelerometer and flex sensor are analog in nature, to convert these analog signals into digital form, we are using in-built ADC of Atmega8 micro controller.

Here, Atmega8 micro controllers continuously read data from accelerometer & flex sensors, and convert them into digital form. This digitized data is compared with the data which is already taken in the accelerometer& flex sensor analysis part. And for every movement of accelerometer some characters are assigned. Now, in the comparison phase digitized data is compared with the pre-defined ranges, and for matched range corresponding character will be transmitted through 2.4 GHz RF transmitter.

V CONTROLLING MECHANISM

To control different movements of robotic arm we are using LPC1768 ARM micro controller board. The LPC1768 is an ARM based microcontroller for embedded applications featuring a high level of integration and low power consumption. The ARM is a next generation core that offers system enhancements such as enhanced debug features and a higher level of support block integration. This micro controller operates at up to a 100 MHz CPU frequency and its CPU incorporates a 3-stage pipeline and uses Harvard architecture with separate local instruction and data buses as well as a third bus for peripherals.

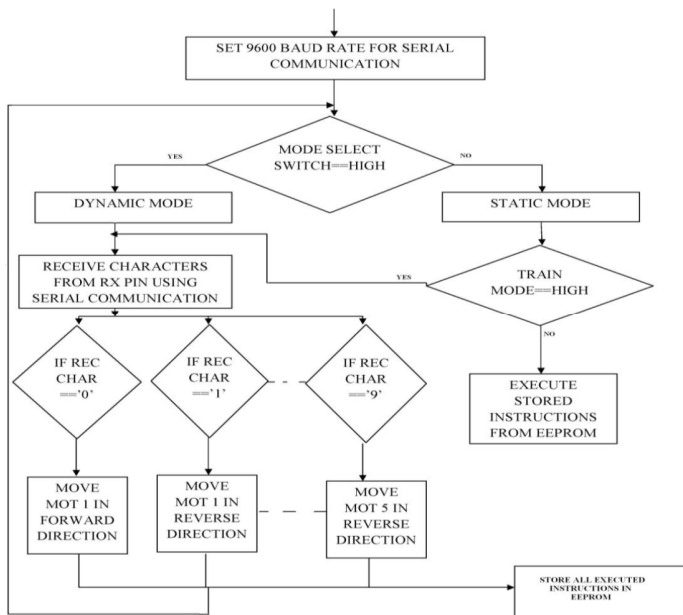

Fig.6 Receiver Flow Chart

RF communication modules are set to 9600 baud rate to receive data . LPC 1768 continuously checks the mode select switch pin, if the pin is high, then the system will work in Dynamic mode i.e. System will give the movements for current receiving values, if there is no received character then no movement will takes place. If the mode select switch is LOW, then the system enters into static mode, in static mode again controller reads the train mode pin, if this pin is HIGH then system enters into training mode where movements will takes place for received characters and simultaneously stores received characters in EEPROM using I2C protocol. If train mode pin is LOW then simply system executes the already stored instructions from EEPROM .

VI.CONCLUSION & FUTURE SCOPE :

Growing demand for natural Human Machine Interfaces and robot easy programming platforms, a gesture recognition system that allows users to control an industrial robotic arm was proposed and implemented successfully. A 3-axis accelerometer was selected to be the input device of this system, capturing the human arm behavior to control the robotic arm movement. And two flex sensors were used to control gripper movement. When compared with other common input devices like teach pendant, this approach using accelerometers over wireless medium is more easy to work. Using this system, a non-expert robot programmer can control a robot quickly and in a natural way. The low price and short set-up time are other advantages of the system.

Future work will build upon increasing the number of accelerometer movement which is possible through the use of highly sensitive accelerometers. One approach might be the implementation of a gyroscope into the system, in order to separate the acceleration due to gravity from the inertial acceleration. The use of more accelerometers attached to the arms is another possibility.

ACKNOWLEDGMENT:

I am thankful to Mr. Sripath Roy & Mr. Mahaboob Ali for their contribution in preparing this paper

REFERENCES:

[1] Fundamentals of Robotics Analysis & Control by Robert J.Schilling  
 [2] Accelerometer-Based Control of an Industrial Robotic Arm Pedro Neto, J. Norberto Pires, Member, IEEE, and A. Paulo Moreira, Member, IEEE  
 [3] R. Dillmann, "Teaching and learning of robot tasks via observation of human performance," in Robotics and Autonomous Systems  
 [4] <http://www.sparkfun.com/tutorials/270>  
 [5] J. Aleotti, A. Skoglund and T. Duckett, "Position teaching of a robot arm by demonstration with a wearable input device," in International Conference on Intelligent Manipulation and Grasping (IMG04)  
 [6] <http://www.esr.co.uk/manuals/ksr10.pdf>  
 [7] K. Murakami, and H. Taguchi, "Gesture Recognition using Recurrent Neural Networks," in Proceedings of ACM CHI'91Conference on Human Factors in Computing Systems  
 [8] [http://www.nxp.com/documents/user\\_manual/UM10360.pdf](http://www.nxp.com/documents/user_manual/UM10360.pdf)  
 [9] S. Calinon, and A. Billard, "Active teaching in robot programming by demonstration," in 16th IEEE International Symposium on Robot And Human interactive Communication  
 [10] [http://www.pmb.co.nz/downloads/st\\_st24c02\\_data.pdf](http://www.pmb.co.nz/downloads/st_st24c02_data.pdf)  
 [11] <http://www.ti.com/lit/ds/symlink/cc2500.pdf>  
 [12] Simple adaptive control of robot arm by Dave E.Goldberg, A.Galip Ulsoy, Y.Koren.  
 [13] [http://www.analog.com/static/imported-files/data\\_sheets/ADXL335.pdf](http://www.analog.com/static/imported-files/data_sheets/ADXL335.pdf)  
 [14] <http://www.atmel.com/images/doc2486.pdf>