

RF Communication from SISO Systems to MIMO Systems: An Overview

Ankita Singhal¹, Nishu Rani¹, Kritika Sengar¹, Dolly Sharma², Seema Verma¹, Tanya Singh²
¹Banasthali university, Newai, India
²Amity Institute of Information and Technology, Noida, India

Abstract The wireless communication has derived to the present scenario after passing through number of stages and generation. From analog communication of 1st generation today we talk about digital communication in 4th generation, from the generation of single transmitting antenna and single receive antenna known as SISO systems, we reached the systems with multiple transmitting and multiple receiving antennas known as MIMO systems going through the systems of Multiple Transmit and single receive antenna systems known as MISO systems and Single transmit and multiple receive systems known as SIMO systems. This paper will present a study of generation from SISO systems to MIMO systems for digital communication under the research work going at Banasthali University, Rajasthan, India.
Index terms- MIMO, SISO, SIMO, MISO, MMSE, ZFE.

I. INTRODUCTION

The traditional digital communication systems involve BPSK modulation or any other modulation scheme and Single transmitting and Single Receive antenna systems. Then came the SIMO systems with single transmitting antennas and multiple receiving antennas. Similar ideas are used in rake receivers for CDMA systems. Different diversity schemes were followed by the systems at the receiving end in order to equalize the receive systems. Same way when MISO systems were in use, different schemes at the transmitting end were employed in order to diversify the transmitting signal and the schemes were known as transmitting diversity schemes. When MIMO systems come, they somehow combine the concepts from both SIMO and MISO systems and form MIMO systems [1][2]. The basic block diagram of the wireless communication system has been shown below in the figure 1.

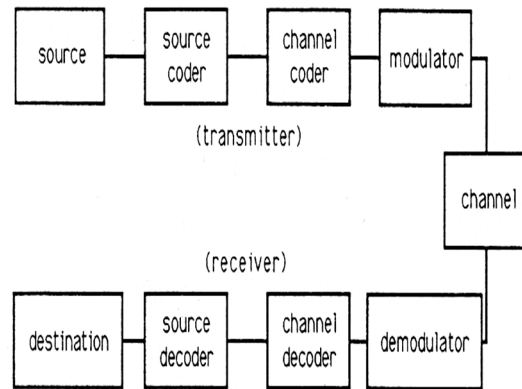

Figure 1 Wireless Communication System

Diversity scheme in wireless communication is a method for improving the quality and correctness of a message signal in which more than one communication channels which differ in their characteristics are used. This is one important scheme to battle with co channel interference and fading of the signal because individual channels result in the different amount of interference and fading and when a signal is transmitted or received with multiple versions, it is easier to combat such issues. The concept of diversity schemes in transmitted end is first came into an existence in the landmark paper of Alamouti which he published in 1998 and laid down the foundation of diversity schemes. Now diversity schemes are used in MISO, SIMO and MIMO systems [2][3][4].

II. SISO SYSTEMS

The SISO systems or single input and single output RF wireless communication systems usually govern the wireless communication systems like 2G are the best suited examples of SISO systems. One antenna at transmitting end for the signal transmission and

one antenna at receiving end for signal reception. The capacity of the system governs by the Shannon's capacity equation:

$$C = B \log(1 + S/N) \dots \dots (1)$$

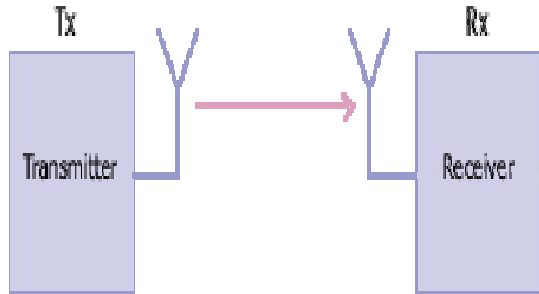

Figure 2 SISO Wireless System

No such equalization of diversity schemes are required in such systems [2][3][5].

III. MISO SYSTEMS

MISO or the multiple input and single output RF Wireless communication systems stands for transmit diversity in which there are multiple antennas to transmit the signal and a single antenna to receive the signal. There are two main schemes for transmit diversity known as transmit beam forming and Alamouti STBC (Space Time Block Coding)[6][7].

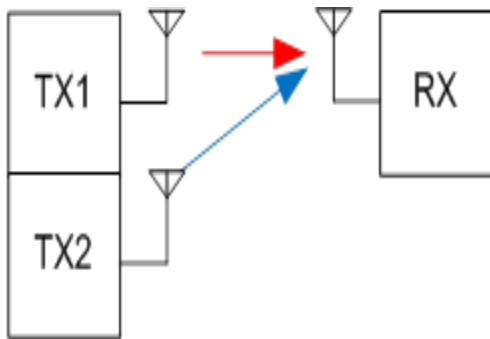

Figure 3 MISO Wireless Communication System

1. When transmit beam forming is applied, we multiply the symbol from each transmit antenna with a complex number corresponding to the inverse of the phase of the channel so as to ensure that the signals add constructively at the receiver[6].

2. A simple Space Time Code, offers a simple method for achieving spatial diversity with two

transmit antennas which is given by Mr. Alamouti in his paper in 1998. This schemes aims to send two symbols from the 1st and 2nd antenna at the first timeslot and complex of the symbols in reverse order i.e. x1 and x2 in first time slot and -x2 and x1 in second time slot from the first and second antenna [6].

IV. SIMO SYSTEMS

SIMO systems or Single input and multiple output RF Communication systems involves schemes for Receiving Diversity which is a form of space diversity, where the signal is received by more than 1 antenna at the receiving end. This brings an important point of discussion of for SIMO systems. How are we going to use the signals when we have multiple signals arriving and all carrying same information? This brings different schemes like selection diversity, equal gain diversity, maximal ratio combining [8][9][10].

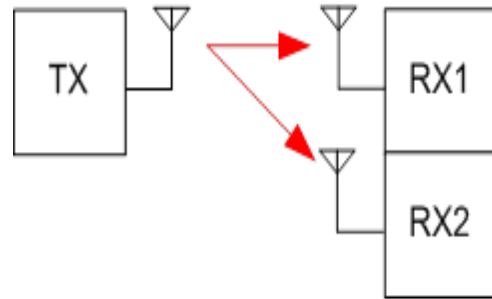

Figure 4 SIMO Wireless Communication System

The diversity schemes at the receiving end are explained below briefly.

1. Selection diversity involves the process of taking the signal with highest power i.e. received signal with higher power will be accepted and rest of the signals will be ignored.
2. Maximal Ratio Combining is a scheme which the strength of the received signals is use to obtain the corresponding weights and then maximizes the SNR.
3. Equal gain combining is another scheme in which it is required to the weights to vary with the fading signals, the magnitude of which may fluctuate over several 10s of dB[10][11].

V. MIMO SYSTEMS

MIMO systems involve multiple inputs and multiple output or the multiple transmitting antennas and multi receive antennas. This is achieved by spreading the total transmitted power over to achieve the array gain, and hence throughput of the channel increases linearly and thus increases the spectral efficiency and link reliability [7].

A. Working of MIMO systems

The entire working of MIMO systems can be divided into three stages:

1. Pre-coding
2. Spatial multiplexing
3. Diversity coding.

1. Pre-coding

It is a multi-stream beam forming. In more common terms it was supposed to be all spatial processing which occurs at the transmitter end.

2. Spatial multiplexing

It needs MIMO antenna configuration. In this technique a high rate signals is splitted into several lower rate signals and each signal is transmitted by a different transmit antenna in a common frequency channel.

3. Diversity Coding

This technique is used if there is no channel knowledge at the transmitter end. In diversity methods, a single stream is transmitted, but the signal is coded using techniques called SPACE-TIME CODING.

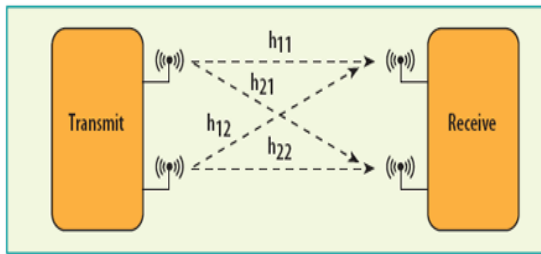

Figure 5 MIMO Wireless Communication System

B. Equalization schemes for MIMO systems

In MIMO systems, equalization is done at the receiving side or at the destination end. There are three different such equalization schemes, we will introduce which are used at the receiver. They are Zero Forcing Equalizer, Minimum Mean Square Error and Maximum Likelyhood Estimator. They are briefly explained below.

1. Zero forcing (ZF) equalizer

Zero Force equalization is a linear equalization process in communication system which inverts the frequency the frequency response of the channel. ZFE restore the transmitted signal by applying the inverse of the channel to the received signal and brings down the ISI. It is a very good scheme to combat ISI when ISI is high as compared to the channel noise [11][12].

Let us define mathematical model for the system, the initial equations will remain same for the three schemes of MIMO systems we will discuss here. Let there be two signals received on antenna 1 and antenna 2, y_1 and y_2 respectively, $h(1,1)$, $h(1,2)$, $h(2,1)$ and $h(2,2)$ are the channel parameters showing the relation between transmitting and receive antenna as shown by the figure 5, x_1 and x_2 are the transmitted signals from antenna 1 and antenna 2 respectively and n_1 and n_2 are the noise on receiving antenna 1 and antenna 2 respectively such that[12]:

$$y_1 = h_{1,1}x_1 + h_{1,2}x_2 + n_1 = [h_{1,1} \quad h_{1,2}] \begin{bmatrix} x_1 \\ x_2 \end{bmatrix} + n_1$$

And

$$y_2 = h_{2,1}x_1 + h_{2,2}x_2 + n_2 = [h_{2,1} \quad h_{2,2}] \begin{bmatrix} x_1 \\ x_2 \end{bmatrix} + n_2$$

The above equations can be expressed in matrix form as

$$\begin{bmatrix} y_1 \\ y_2 \end{bmatrix} = \begin{bmatrix} h_{1,1} & h_{1,2} \\ h_{2,1} & h_{2,2} \end{bmatrix} \begin{bmatrix} x_1 \\ x_2 \end{bmatrix} + \begin{bmatrix} n_1 \\ n_2 \end{bmatrix}$$

i.e. $Y = Hx + n$

Now x can be solved by with the help of the matrix Z such that $ZH=1$, i.e. Z should be the inverse of the channel matrix H . the matrix Z can be expressed mathematically as

$$Z = (H^H H)^{-1} H^H$$

The term,

$$H^H H = \begin{bmatrix} h_{1,1}^* & h_{1,2}^* \\ h_{2,1}^* & h_{2,2}^* \end{bmatrix}$$

$$= \begin{bmatrix} |h_{1,1}|^2 + |h_{2,1}|^2 & h_{1,1}^* h_{1,2} + h_{2,1}^* h_{2,2} \\ h_{1,2}^* h_{1,1} + h_{2,2}^* h_{2,1} & |h_{1,2}|^2 + |h_{2,2}|^2 \end{bmatrix}$$

Figure 6 The Final matrix of ZFE

For BPSK modulation in Rayleigh fading channel, the bit error rate is derived as,

$$P_b = \frac{1}{2} \left(1 - \sqrt{\frac{(E_b/N_0)}{(E_b/N_0) + 1}} \right)$$

2. Minimum Mean Square Error

Minimum mean square error (MMSE) is an estimation scheme which minimizes the mean square error and one very common method used for quality estimation. This does not remove the ISI but however it reduces or minimizes the components of noise and ISI in the output. The MMSE finds a coefficient M which minimizes criteria:

$$E\{[My - x][My - x]^H\}$$

On solving the above criteria, the mathematical value of M comes out to be:

$$M = [H^H H + N_0 I]^{-1} H^H$$

If we compare the equation of ZFE with MMSE, both the equation seems similar apart from the term NoI that means in the absence of noise, MMSE and ZFE works similar to each other[6][13][14][15].

3. ML Equalization

The ML or maximum Likelihood equalization schemes finds out the term m, such that

$$J = |y - Hm|^2$$

can be minimized. This relation can be further expresses in terms of received signal, channel parameters and m

$$J = \left| \begin{bmatrix} y_1 \\ y_2 \end{bmatrix} - \begin{bmatrix} h_{1,1} & h_{1,2} \\ h_{2,1} & h_{2,2} \end{bmatrix} \begin{bmatrix} m_1 \\ m_2 \end{bmatrix} \right|^2$$

As with BPSK modulation, value of x1 and x2 can be either +1 or -1, hence to find the ML solution, all the

four combinations below for x1 and x2 need to be minimized[14][15][16].

$$J_{+1,+1} = \left| \begin{bmatrix} y_1 \\ y_2 \end{bmatrix} - \begin{bmatrix} h_{1,1} & h_{1,2} \\ h_{2,1} & h_{2,2} \end{bmatrix} \begin{bmatrix} +1 \\ +1 \end{bmatrix} \right|^2$$

$$J_{+1,-1} = \left| \begin{bmatrix} y_1 \\ y_2 \end{bmatrix} - \begin{bmatrix} h_{1,1} & h_{1,2} \\ h_{2,1} & h_{2,2} \end{bmatrix} \begin{bmatrix} +1 \\ -1 \end{bmatrix} \right|^2$$

$$J_{-1,+1} = \left| \begin{bmatrix} y_1 \\ y_2 \end{bmatrix} - \begin{bmatrix} h_{1,1} & h_{1,2} \\ h_{2,1} & h_{2,2} \end{bmatrix} \begin{bmatrix} -1 \\ +1 \end{bmatrix} \right|^2$$

$$J_{-1,-1} = \left| \begin{bmatrix} y_1 \\ y_2 \end{bmatrix} - \begin{bmatrix} h_{1,1} & h_{1,2} \\ h_{2,1} & h_{2,2} \end{bmatrix} \begin{bmatrix} -1 \\ -1 \end{bmatrix} \right|^2$$

Figure 7 Cases for ML equalization to be minimized

The estimate of the transmit symbol is chosen based on the minimum value from the above four values i.e

If the minimum is $J_{+1,+1} \Rightarrow [1 \ 1]$

If the minimum is $J_{+1,-1} \Rightarrow [1 \ 0]$

If the minimum is $J_{-1,+1} \Rightarrow [0 \ 1]$

If the minimum is $J_{-1,-1} \Rightarrow [0 \ 0]$

VI. CONCLUSION

The paper provides a detailed review on different schemes for SISO, MISO, SIMO and MIMO systems. Also the various schemes of diversity and equalization underlying schemes are properly presented and explained in the paper. All these schemes have their pros and cons and they are needed to work more to optimize the performance of the system. The further extension in this project is to simulate all the schemes we mentioned here and to move further. This paper will provide a proper literature platform for the upcoming researchers to start working in this domain.

References

- [1] Digital Communication: Third Edition, by John R. Barry, Edward A. Lee, David G. Messerschmitt
- [2] Fundamentals of Wireless Communication, David Tse, Pramod Viswanath
- [3] Wireless communications and Networking by VIJAY GARG.

- [4] R. Scholtz, "Multiple Access with Time-Hopping Impulse Modulation," IEEE milit. Commun. Conf., vol. 2, pp. 447-450, 1993.
- [5] Wireless communications and networks : second edition, by Theodore S. Rappaport
- [6] R. T. Derryberry, S. D. Gray, D. M. Ionescu, G. Mandyam, and B. Raghothaman, "Transmit diversity in 3G CDMA systems," IEEE Commun. Mag., vol. 40, no. 4, pp. 68–75, Apr. 2002.
- [7] A. J. Paulraj, D. A. Gore, R. U. Nabar, and H. Boelcskei, "An overview of MIMO communications -A key to gigabit wireless," Proc. IEEE, vol. 92, no. 2, pp. 198–218, Feb. 2004.
- [8] MIMO-OFDM modem for WLAN by, Authors: Lisa Meilhac, Alain Chiodini, Clement Boudesocque, Chrislin Lele, Anil Gercekci.
- [9] G. Leus, S. Zhou, and G. B. Giannakis, "Orthogonal multiple access over time- and frequency-selective channels," IEEE Transactions on Information Theory, vol. 49, no. 8, pp. 1942–1950, 2003.
- [10] P. A. Bello, "Characterization of randomly time-variant channels," IEEE Transactions on Communications, vol. 11, no. 4, pp. 360–393, 1963.
- [11] B. G. Evans and K. Baughan, "Visions of 4G," Electronics and Communication Engineering Journal, Dec. 2002.
- [12] "ZERO-FORCING EQUALIZATION FOR TIME-VARYING SYSTEMS WITH MEMORY " by Cassio B. Ribeiro, Marcello L. R. de Campos, and Paulo S. R. Diniz.
- [13] A. Adjoudani, E. Beck, A. Burg, G. M. Djuknic, T. Gvoth, D. Haessig, S. Manji, M. Milbrodt, M. Rupp, D. Samardzija, A. Siegel, T. S. II, C. Tran, S. Walker, S. A. Wilkus, and P. Wolniansky, "Prototype Experience for MIMO BLAST over Third-Generation Wireless System", Special Issue JSAC on MIMO Systems, vol. 21, pp. 440–451, Apr. 2003.
- [14] P. Murphy, F. Lou, A. Sabharwal, J.P. Frantz, "An FPGA based rapid prototyping platform for MIMO systems", Proc. of Asilomar, vol. 1, pp. 900–904, Nov. 2003.
- [15] "System requirements for IEEE 802.20 mobile broadband wireless access systems," IEEE, Draft IEEE 802.20-PD-06 version 14, July 2004.
- [16] T. Kaiser, A. Wilzeck, M. Berentsen, and M. Rupp, "Prototyping for MIMO Systems - An Overview", in Proc. of the 12th European Signal Processing Conference (EUSIPCO), pp. 681–688, Vienna, Austria, Sept. 2004.