

Monitoring and Control System for Industrial Parameters Using Can Bus

SargunaPriya.N¹, Jothi Mani.M², Amudha.P³

(Department of Electronics & Communication Engineering, Erode Sengunthar Engineering College, Erode.)

ABSTRACT: *In modern industrial production, the working temperature change reflects the operating status of equipments and change of many physical characteristics. So the temperature is an important parameter, which needs to be monitored. The workers can make right judgments and operation by a temperature monitor. The embedded microcontroller is used as a CPU of the system. The system realizes the real-time remote data collection monitoring and storage through the CAN bus protocol. In the industrial monitoring field, the parameters are sensed by the respective sensors and are monitored by the individual microcontrollers. Finally, the values are displayed with the help of individual LCD displays. All the parameters such as temperature, pressure and water level are sensed by the sensors and their respective codes are installed in the PIC microcontroller. The microcontroller is connected to the PC through CAN bus and the output will be displayed in that PC with the help of RS232 serial communication. The system platform can be applied to certain equipments of the power system, intelligent industrial remote monitoring, intelligent furniture monitoring, intelligent warehouse monitoring and so on. The system is reliable and stable. It is the most effective and most economical means of equipment safety monitoring. So it has very good social prospects.*

KEYWORDS: *CAN bus protocol, Control, Microcontroller, Monitor, Sensors.*

I. INTRODUCTION

Now- a- days, the industrial monitoring field requires more manual power to monitor and control the industrial parameters such as pressure, temperature, water level, etc... This is one of the most upcoming issues in the industrial sectors. If the parameters are not monitored and controlled properly, it leads to a harmful situation. Most of the

industries are facing these kinds of situation because of some manual mistakes.

In that kind of harmful situations, again the manual power is required to control the parameters. Sometimes, if this control process may not be handled properly, it results in an occurrence of major accidents. So, every process in the industrial sector requires more manual power which is also having issues with the unavoidable manual mistakes. With the upcoming technologies, it is very easy to overcome the greater issues in the industrial automation.

In the industrial monitoring field, the various sensors such as pressure sensor, temperature sensor and level sensor are used for sensing the parameters and the sensed values are processed by the microcontroller. The processed values are then displayed through the respective LCD displays. Finally, with the help of CAN (Controller Area Network) bus communication the overall industrial parameters are monitored through a single PC. The CAN bus communication is a wired communication and it is working under the priority of message i.e., CAN is a message based protocol. So, the control process will also be handled by this CAN bus communication.

The objective of this project is to design the monitoring and control system for industrial parameters using CAN bus communication. This system mainly reduces the high manpower requirement in the industrial monitoring field by monitoring the overall industrial parameters through a single PC with the help of CAN bus application. This system also provides an automatic control of parameters during an emergency situation.

II. SYSTEM ANALYSIS AND REQUIREMENTS

1. Existing system

In olden methods, the industrial parameters are monitored through individual LCD displays. With the help of various sensors, the parameters are sensed

and the values are processed by the microcontrollers. Then, the processed values are displayed in the individual LCD displays which are connected to the microcontrollers. For monitoring the parameters in various locations, the individual microcontrollers and LCD displays are required. The parameters have to be monitored continuously. In case, the sensed parameter value exceeds certain value at the instant of monitoring, the control process will be handled by the workers of the industry.

1.1 Drawbacks

- Because of monitoring the industrial parameters through individual LCD displays, this method requires more manual power to monitor them continuously.
- In case the workers fail to monitor the parameters continuously, it leads to a harmful situation. In that kind of harmful situations, again the manual power is required to control the parameters. If the control process may not be handled properly, it results in major accidents.
- So, every process in the industrial sector requires more manual power which is also having issues with the unavoidable manual mistakes.
- And the maintenance of the system is very difficult and it also requires more manual power.

2. Proposed system

In this system, the implementation of CAN bus application in the industrial automation helps to monitor the overall industrial parameters through a single PC. This reduces the high manpower requirement in the industrial monitoring field and this system provides automatic control of the parameters by CAN bus application, in case the sensed value exceeds a fixed value. This system having various sensors such as pressure sensor, temperature sensor and level sensor and are used to sense the parameters. The sensed values are then processed by the microcontroller and are displayed through the respective LCD displays. Finally, with the help of

CAN (Controller Area Network) bus communication the overall industrial parameters are monitored through a single PC. The CAN bus communication is a wired communication and it is working under the priority of message. By this CAN bus communication, the control process will be handled automatically if the sensed parameter value exceeds the fixed value.

3. System requirements

- Temperature Sensor- Thermistor
- Pressure Sensor- Diaphragm
- Water level Sensor- Float Transducer
- PIC Microcontroller-16F877A
- CAN Bus, CAN Controller, CAN Controller Interface
- LCD Display
- Relay
- Solenoid Valve, Heater and Pump
- RS232 Serial Port
- Personal Computer
- MPLAB IDE
- Visual Basic

III. PROJECT DESCRIPTION

1. Problem definition

Now-a-days, the industries require more manual power to monitor and control the parameters like pressure, temperature, water level, etc... with the help of individual Microcontrollers and LCD displays in various locations. Here, the sensing equipments are used to sense the various parameters. In case the parameters will not be monitored and controlled properly at the time of emergency, it leads to a harmful situation.

So, the method of monitoring the overall industrial parameters through a single computer and a concept of automatic control will reduce the high manpower requirement. In this method, the industrial parameters like pressure, temperature and water level are sensed by the respective sensors and are monitored by the individual Microcontrollers. Then, the values are displayed by using the individual LCD displays in the respective locations. Finally, the

overall parameter values are monitored in a single PC by using CAN bus application and it can also control the parameters automatically.

1.1 Overview of the project

The general objective of this project is to design the monitoring and control system of industrial parameters using CAN bus communication. This project is used to reduce the high manpower requirement in industries by monitoring the overall parameters through a single PC with the help of CAN bus communication. And also controls the parameters without any manual operation. Basically, this project is designed with microcontrollers and various sensors such as pressure sensor, temperature sensor and level sensor. Additionally, this system has Can Bus with interface and controller to transmit data from microcontroller to computer and RS232 serial port with MAX 232 to interface with PC.

For the control process, this system has solenoid valve, heater, pump which controls the pressure, temperature and water level. The control process will automatically take place, only if the parameter exceeds the fixed value. For an instance, the pressure is sensed by the Diaphragm, a type of transducer in the pressure sensor circuit. The sensed data is then amplified by the operational amplifiers used in the pressure sensor circuit. Here, the PIC 16F877A microcontroller performs various operations like converting the received analog signals into digital values with the help of in-built ADC converter, storing the data with the help of FLASH memory, etc...to monitor the sensed values through a LCD display connected with the microcontroller. Likewise the temperature and the water level in various places are sensed by the thermistor and float sensors and are monitored in the individual LCD displays with the help of individual microcontrollers.

Finally, the overall parameters are monitored in a single PC with the help of CAN bus and RS232 serial port. If the received value in the PC exceeds the fixed value, the parameters will be automatically controlled. It is done by the control equipments like solenoid valve to control the pressure; the heater to control the temperature and the pump to control the water level. They are communicated with the help of CAN bus, and operated with the help of microcontroller and relay.

Because of this monitoring and control system of overall industrial parameters in a single PC with the help of CAN bus application, the manual mistakes by the workers will be avoided. Hence, the workers in the industry will be saved from the harmful situations. The block diagram of this monitoring and control system of industrial parameters using CAN bus communication that involving the transmitter section and the receiver section is shown. Since the CAN bus communication is a wired communication it is used for limited areas and can be extended by the CAN repeaters or by the CAN bridges.

IV. FIGURES

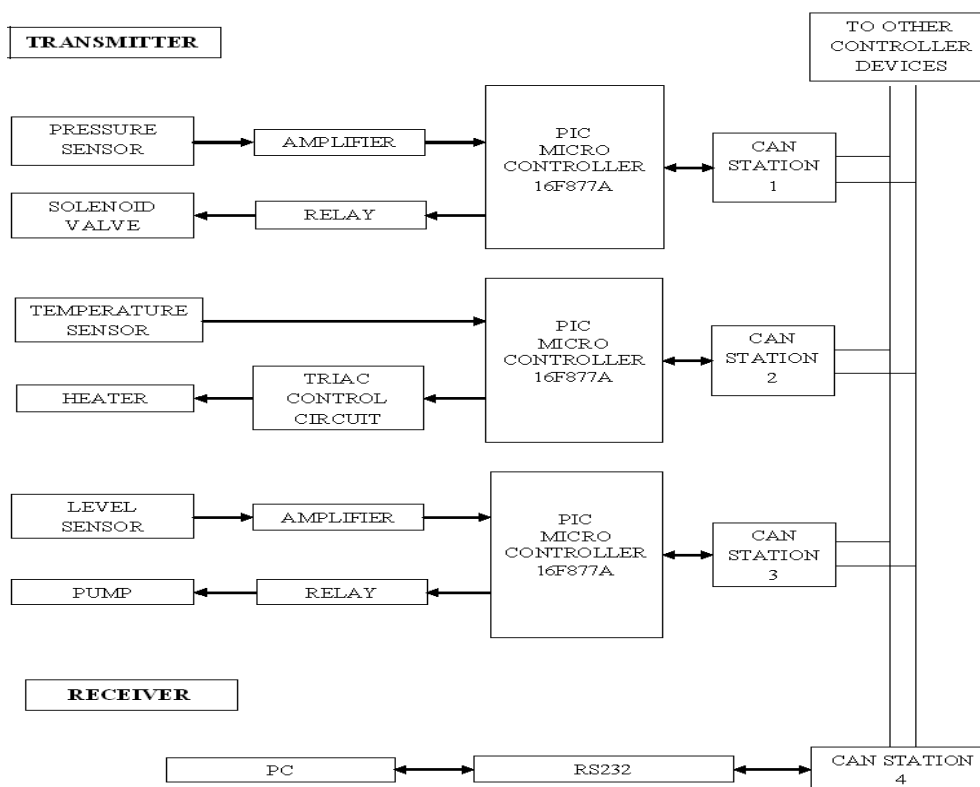

Fig 1.1 Block Diagram

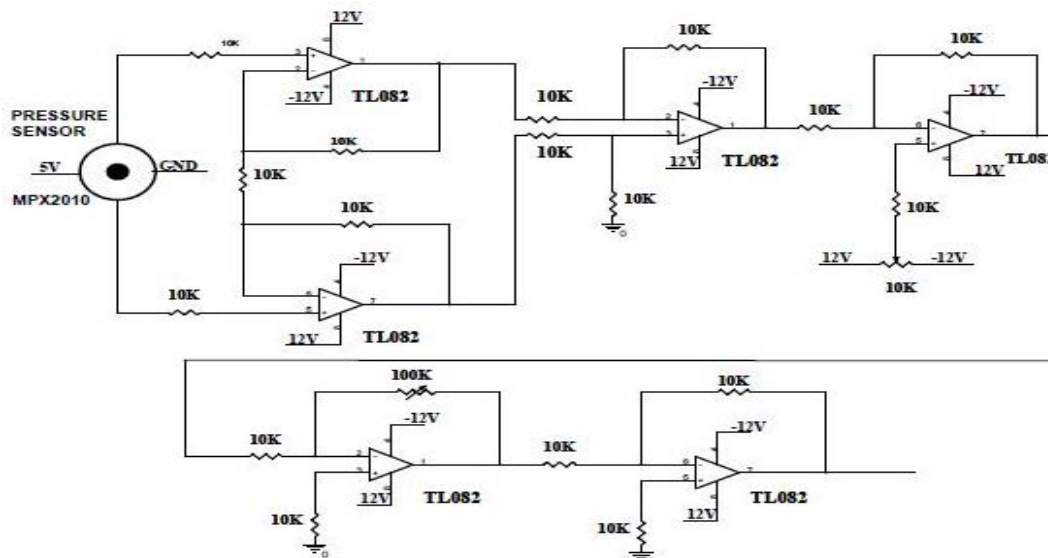

Fig 1.2 Pressure Sensor Circuit

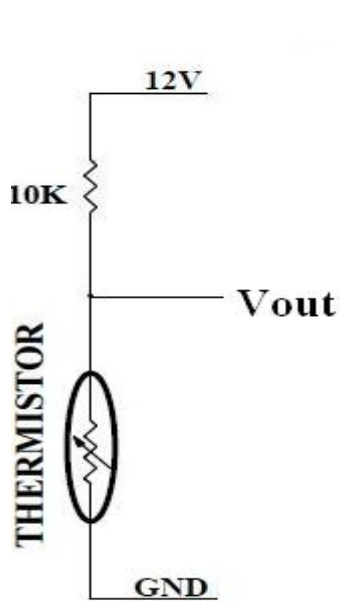

Fig 1.3 Temperature Sensor Circuit

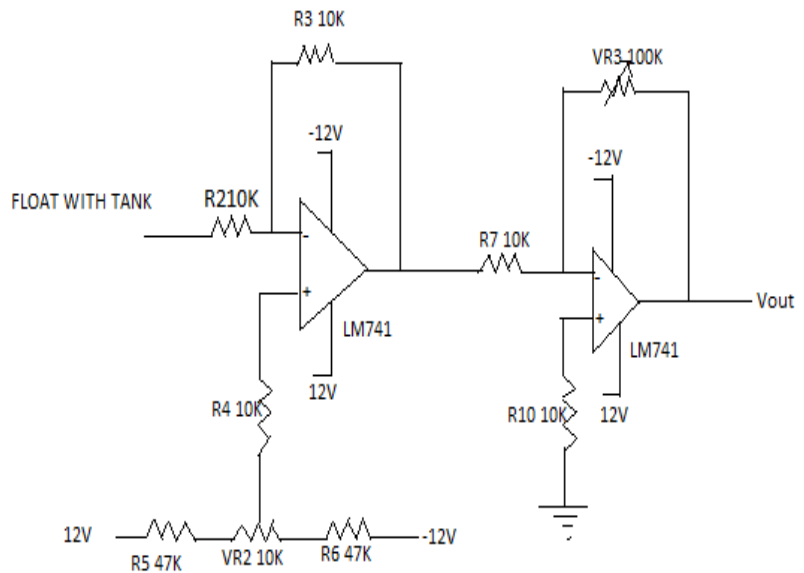

Fig 1.4 Level Sensor Circuit

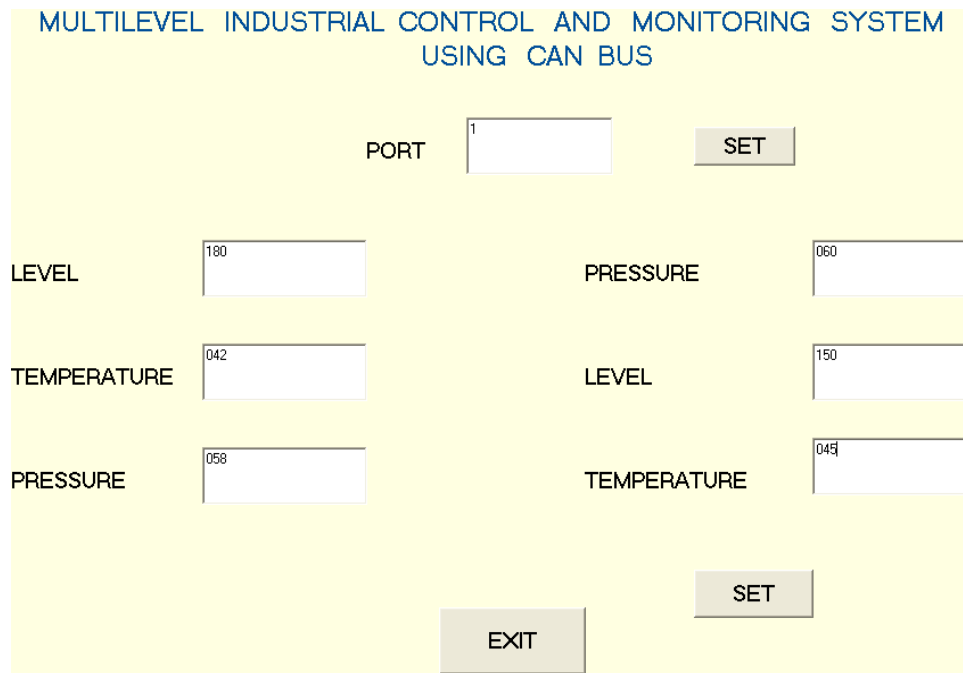

Fig 1.5 Result of Implementing VB in PC

V.CONCLUSION

As a conclusion, the primary objective of this system is fulfilled by monitoring the pressure, temperature and water level in several locations through a single Personal Computer with the help of various sensors, microcontrollers and by the application of CAN bus communication. For the monitoring and control system, the development of MPLAB IDE for microcontrollers and Visual Basic for monitoring the temperature, pressure and water level through PC are achieved. This system also provided the automatic control of industrial parameters using CAN bus application.

REFERENCES

[1]Zhang Lihong, Sun Lei, Han Shufen, Lu Weina, Hebei, “*Measurement and Control System of Soil Moisture of Large Greenhouse Group Based on Double CAN Bus*”, ICMTMA, Third International Conference, China, Jan 06, 2011

[2]Xiaoming Li, Mingxiong Li, “*An Embedded CAN-BUS Communication Module for Measurement and Control System*”, ICEEE, International Conference, China, Nov 07, 2010

[3]Renjun Li, Chu Liu, Feng Luo, “*A design for automotive CAN bus monitoring system*”, VPPC, Shanghai, Sept 03, 2008

[4]Donglin Wang, Chandana. S, Renlun He, Jiuqiang Han, Xiangyu Zhu, Ke Zou, Yong He, “*Intelligent Sensor Design in Network Based Automatic*

Control”, ICJNN,International Joint Conference, Canada, July 18,2010

[5]Mahmoud Meribout, “*A Multi-sensor Device for Real-Time Multiphase Flow Metering*”, Instrumentation & Measurement, IEEE ,July 8,2010

[6]Jinsoo Han ,Haeryong Lee, “*Remote-Controllable and Energy-Saving based on ZigBee*”, Consumer Electronics, IEEE, August 1,2009

[7]Ying-Wen Bai and Chi-Huang Hung, “*Remote Power On/Off Control and Current Measurement for Home Electric Outlets Based on a Low- Power Embedded Board and ZigBee Communication*” ,Proceedings of the 2008 International Symposium on Consumer Electronics, Algarve, Portugal, 14-16 Apr. 2008

[8]Jui-Yu Cheng, Min-Hsiung Hung, and Jen-Wei Chang, “*A ZigBee- Based Power Monitoring System with Direct Load Control Capabilities*” , Proceedings of the 2007 IEEE International Conference on Networking, Sensing and Control, London, UK, 15-17 Apr. 2007

[9] C. H. Lo, Y. K. Wong, and A. B. Rad, “*Intelligent system for process supervision and fault diagnostic in dynamic physical systems*” ,IEEE Trans. Ind. Electron., vol. 53, no. 2, pp. 581–592, Apr. 2006

[10]J. Chaoki, L. Larachi, and M. P. Dudoković, “*Non-Invasive Monitoring of Multiphase Flows*”, Amsterdam, The Netherlands: Elsevier, 2006