

Fabrication and Analysis of Counter Flow Helical Coil Heat Exchanger

Swapnil Ahire¹, Purushottam Shelke², Bhalchandra Shinde³, Nilesh Totala⁴

^{1,2,3}Student, ⁴Assistant Professor,

^{1,2,3,4}Department of Mechanical Engineering, MIT AOE, Pune, India

Abstract— Heat recovery is the capture of energy contained in fluids otherwise that would be lost from a facility. Heat sources may include heat pumps, chillers, steam condensate lines, hot flue gases from boiler, hot air associated with kitchen and laundry facilities, exhaust gases of the engines, power-generation equipment. Helical coil heat exchanger is one of the devices which are used for the heat recovery system. A heat exchanger is a device used to transfer heat between two or more fluids with different temperatures for various application including power plants, nuclear reactors, refrigeration & air condition system, automotive industries, heat recovery system, chemical processing and food industries. Common examples of heat exchangers in everyday use are air pre-heaters and conditioners, automobile radiators, condensers, evaporators, and coolers In present paper analysis of counter flow heat exchanger is done and then variations of various dimensionless numbers i.e. Reynolds Number, Nusselt's Number and Dean's number are studied.

Keywords— Reynolds Number, Nusselt's Number, Dean's Number, overall heat transfer coefficient.

I. INTRODUCTION

Besides the performance of the heat exchanger being improved, the heat transfer enhancement enables the size of the heat exchanger to be considerably decreased. Helical coil heat exchangers are one of the most common equipment found in many industrial applications.

Several studies have indicated that helically coiled tubes are superior to straight tubes when employed in heat transfer applications. The centrifugal force due to the curvature of the tube results in the secondary flow development which enhances the heat transfer rate. This phenomenon can be beneficial especially in laminar flow regime. Thermal performance and pressure drop of a shell and helically coiled tube heat exchanger with and without helical crimped fins have been investigated by Naphon. Naphon and Wongwiseprovided a literature review on heat transfer and flow characteristics of single-phase and two-phase flow in curved tubes including helically coiled tubes and spirally coiled tubes.

The majority of the studies related to helically coiled tubes and heat-exchangers have dealt with two major boundary conditions, i.e. constant heat flux and constant wall temperature. However, these boundary conditions are not encountered in most single-phase heat exchangers.

Helical coils are used for various processes such as heat exchangers because they can accommodate a large heat transfer area in a small space, with high heat transfer coefficient. In the coiled tube, the flow modification is due to centrifugal forces. The centrifugal forces are acting on the moving fluid due to the curvature of the tube results in the development of secondary flow which enhances the heat transfer rate. This phenomenon can be beneficial especially in laminar flow. Helical coiled tubes are used in a variety of applications including food processing nuclear reactors, compact heat exchangers, heat recovery systems, chemical processing and medical equipment.

W. Witchayanuwat, S. Kheawhom presented a detailed investigation on heat transfer from exhaust particulate air of detergent spray drying tower to water by helical coiled heat exchanger. It was found that the effect of coil pitch on the tube side and shell side heat transfer coefficient. The exchanger duty, overall heat transfer coefficient are investigated as function of the tube surface geometry, the flow pattern(parallel and counter) and tube Reynolds number. The result shows that the increasing of the coiled tube pitch decreases the inside Nusselt number.

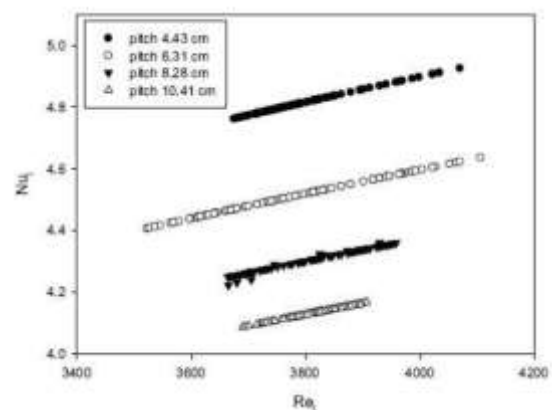

Fig no. 1 Inside Nusselt number vs. Inside Reynolds number for various coiled tube pitch

Salimpour investigated three heat exchanger with different coil pitches and found that the shell-side heat transfer coefficient of coils with larger pitches is higher than those with smaller pitches for the counter-flow configuration. Also, two correlations were developed to predict the inner heat transfer coefficients and the outer heat transfer coefficients of the coiled tube heat exchanger.

Pandiyarajan V. have experimentally investigated on heat recovery system from diesel engine exhaust using finned shell and tube heat exchanger and thermal storage system. The exhaust gas of a diesel engine carries a lot of heat and this energy can be recovered efficiently using heat recovery heat exchanger (HRHE). The investigation has shown the following conclusion:

- The effectiveness of the HRHE approaches nearly 99% at the end of charging process at all conditions.
- Nearly 10-15% of total heat is recovered with this system. The maximum heat extracted using the heat exchanger at full load condition.
- Both the charging rate and charging efficiency are very high at higher load and they decreases with respect to load.

Xiaojun shi investigated experimentally and theoretically the heat recovery steam generator by finned tube heat exchanger. It was found that the difference factor between the humid air dry air decreases with increase in air side Reynolds number.

C. Y. Wang studied the effect of curvature and torsion on the flow in helical pipe numerically by spectral method. Prabhanjan experimentally investigated the natural convection heat transfer from helically coiled tubes in water. They

reported that different lengths were used to correlate the outside Nusselt number to the Rayleigh number. Models were developed to predict the outer temperature fluid flow through the helical coiled heat exchanger. The best correlation employed the total height of the coil as the characteristic length. They developed a model to predict the outlet temperature of a fluid flowing through a helically coiled heat exchanger, given the inlet temperature, bath temperature, coil dimensions, and fluid flow rate. The predicted outlet temperature was compared to measured values from an experimental setup. The results of the predicted temperatures were close to the experimental values and suggest that the method presented has promise as a method of predicting outlet temperatures from similarly dimensioned heat exchangers.

The published result shows effect of curvature ratio, pitch and centrifugal forces on a flowing fluid as follows:

- Curvature increases resistance
- Pitch decreases resistance
- Secondary flow in the plane normal to the pipe axis is induced.

Vimal kumar investigated the hydrodynamics and heat-transfer characteristics of coiled flow inverter as heat exchanger. The new design of CFI as heat exchanger presented which comprised of coils and 90° bends. The insertion of 90° bends between the coiled tubes generates inversion flow that increases the fluid mixing and enhances the heat transfer. The efficiency of the heat exchanger at low Reynolds number was near one and as the Reynolds number increases the efficiency decreases. Overall heat-transfer coefficient was calculated at various tube and shell side process conditions.

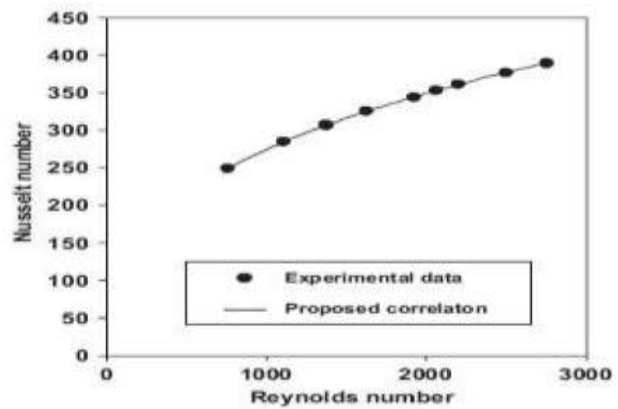
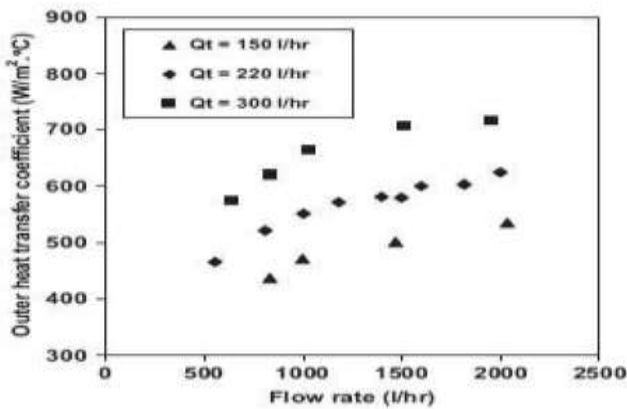

Fig no. 2 Variation of outer heat transfer coefficient and Nusselt number.

It was observed that the overall heat-transfer coefficient increases with increase in the tube side Reynolds number for a constant flow rate in the shell side. Similar trends in the variation of overall heat-transfer coefficient were observed for different flow rates in the shell side for a constant flow rate in the chaotic tube. The result shows that at low Reynolds numbers, heat transfer is 25% higher as compared to coiled

tubes. At high Reynolds numbers, the configuration has less influence on heat transfer.

Jose Fernandez-Seara studied the review paper is that the Wilson plot method and the different modified versions of the Wilson plot method constitute a remarkable tool for the analysis of convection heat transfer in tubes and heat exchangers for laboratory research usage. The trademark of

the Wilson plot methods is that they assist in the determination of convective coefficients based on experimental data. The Wilson plot method and is an indirect tool to generate accurate correlation equations for convective coefficients of secondary fluids in different types of heat exchange devices. A review of these indirect applications is addressed. However, it is noteworthy that, if

the Wilson plot method is applied indirectly, usually the authors only quote its application and do not provide detailed information on how it was implemented. Therefore, the aim of the references to be cited lists the great variety of indirect applications that have been tackled by researchers. These references have been grouped according to the type of heat transfer process considered.

Shokonhmand et al. carried out an experimental study of shell-and-coil heat exchangers using Wilson plots, where Wilson plot is a technique to estimate the heat transfer coefficients in several types of heat transfer processes and to obtain general heat transfer correlations. This method is an outstanding tool in practical applications and in laboratory research activities that involve analysis of heat exchangers.

They tested three heat exchangers for both parallel-flow and counter-flow configuration. These heat exchangers have different coil pitches and curvature ratios, and Wilson's plot was used to calculate the overall heat transfer coefficients of the heat exchangers.

The first observations of the curvature effect on flow in coiled tubes were noted at the turn of the 20th century. Grindley and Gibson (1908) noticed the curvature effect on flow in a coiled pipe while performing experiments on air viscosity. It was noted by Williams et al. (1902) that the location of the maximum axial velocity is shifted towards the outer wall of a curved tube. Eustice (1910) noted an increase in resistance to flow for the curved tube compared to the straight tube and this increase in resistance could be correlated to the curvature ratio. However, in coiling the tubes, considerable deformation occurred in the cross section of the tubes for some of the trials, causing an elliptical cross sectional shape. Eustice (1911) also noted that the curvature, even slight, tended to modify the critical velocity that is a common indicator of the transition from laminar to turbulent flow. By using ink injections into water flowing through coiled tubes, U-tubes and elbows, Eustice (1911) observed the pattern of the secondary flow. This secondary flow appears whenever a fluid flows in a curved pipe or channel. Eustice (1911) also noted the same general motion in turbulent flow when sand was introduced into a curved pipe.

The first attempt to mathematically describe the flow in a coiled tube was made by Dean (1927, 1928). The first paper (Dean, 1927) described a first approximation of the steady motion of incompressible fluid flowing through a coiled pipe with a circular cross-section. Although this

approximation did give qualitative agreement with experimental observations, it failed to show the relation between the pressure gradient, the flow rate and the curvature for a curved pipe. In his successive work, Dean (1928) observed that the reduction in the rate of flow due to curvature depends on a single variable, K , which is equal to $2(Re)2r/R$ when the motion is slow, where Re is the Reynolds number, r is the radius of the pipe, and R is the radius of curvature. However, this work was done with the assumption that the ratio of r/R is small. This assumption greatly simplifies the four fundamental equations (continuity equation and the three momentum equations) without affecting the most important terms that decide the effect of curvature on the motion. Dean (1928) also noted that his analytical calculations only applied to stream-line motion. Dean's (1928) explanation for the requirement of a higher pressure gradient to maintain a given flow rate in a curved pipe was that some of the fluid is in continual oscillation between the central part of the pipe, where the velocity is high, and the outer portion of the pipe, where the velocity is low. This movement is due to the centrifugal forces caused by the pipe curvature and results in a loss of energy. This movement has no counterpart in streamline flow in straight pipes. Dean (1928) also presented the ratio of the flux in a curved pipe to that in a straight pipe for the same pressure gradient as being a function only of K for small r/R ratios. The relationship developed was only applicable up to $K = 650$.

C. M. White (1929) furthered the study of Dean for the laminar flow of water and mineral oil of different viscosities through curved pipes with curvature ratios of 1/15, 1/50, and 1/2050. White (1929) showed that the onset of turbulence did not depend on the value of the Reynolds number alone, nor the Dean criteria [$De = Re(r/R)1/2$]. For a curvature of 1/15, a Reynolds number of 9000 was needed to sustain turbulence, whereas for a curvature ratio of 1/2050 no marked difference for the critical velocity was needed to achieve turbulence compared to a straight tube. White (1929) concluded flow in curved pipes is more stable than flow in straight pipes. White (1929) also studied the resistance to flow as a function of the Dean criteria and the Reynolds number. For values of De less than 11.6, there was no difference in flow resistance compared to a straight pipe.

Topakoglu (1967) used an approximate solution using stream-functions to determine the flow pattern for steady laminar flows of an incompressible viscous fluid in curved pipes. Results showed that the flow rate depended on two independent variables, the Reynolds number and the curvature of the pipe.

McConalogue and Srivastava (1968) performed numerical studies to determine the characteristics of the secondary flow for fully developed laminar flow. Their results showed that as the axial velocity was increased, the maximum value of the axial velocity moved towards the outer wall and the secondary vortices also migrated closer to the outer wall.

In the coiled tube, the flow modification is due to centrifugal forces. The centrifugal forces are acting on the moving fluid due to the curvature of the tube results in the development of secondary flow which enhances the heat transfer rate but pressure drop also increases. Vimal Kumar et al. experimentally and numerically studied the tube in tube heat exchanger. Another research done on coiled inverter flow. The different types of baffles used to increase the turbulence. Experimentally observed the tube side pressure drop and heat transfer. They present the variation of pressure drop versus tube side mass flow rate on different modules. The pressure drop increases with increase number of bends. The new empirical correlation developed for friction factor and heat transfer.

A. Background

The various types of heat transfer enhancement techniques are classified into two main categories viz. active and passive technique. Active techniques which require external power for heat transfer enhancement, and passive techniques which does not require such external power for enhancement. One of the passive techniques is the use of helically coiled tubes. Helical coiled tubes are superior to straight tube due to their compactness and increased heat transfer coefficients. Several papers were studied which indicate that use of helical coils adds efficiency to the heat exchanger performance because of their high heat transfer rates and smaller space requirements. Helical coils are widely used in piping systems, heat exchangers, storage tanks, chemical reactors and many other engineering applications. Process heat transfer with conventional shell and tube heat exchangers is familiar to many industries. Their use and performance is well.

The double pipe heat exchanger would normally be used for many continuous systems having small to medium heat duties. However, helical coil heat exchanger might be better choice in some cases:

- Where space is limited, so that not enough straight pipe can be laid.
- Under conditions of laminar flow or low flow rates, where a shell-and-tube heat exchanger would become uneconomical because of the resulting low heat transfer coefficients.

In the coiled tube, the flow modification is due to centrifugal forces. The centrifugal forces are acting on the moving fluid due to the curvature of the tube results in the development of secondary flow which enhances the heat transfer rate. This phenomenon can be beneficial especially in laminar flow. When a fluid flows through a straight tube, the fluid velocity is maximum at the tube center, zero at the tube wall & symmetrically distributed about the axis. However, when the fluid flows through a curved tube, the primary velocity profile is distorted by the addition of secondary flow pattern. Figure 3 shows the secondary flow pattern in coiled tube.

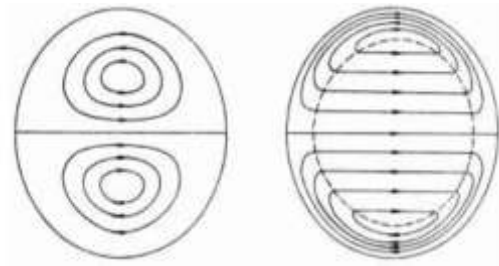

Fig.3 Secondary flow pattern in coiled tube

The secondary flow is generated by centrifugal action and acts in a plane perpendicular to the primary flow. Since the velocity is maximum at the centre, the fluid at the centre is subjected to the maximum centrifugal action, which pushes the fluid towards the outer wall. The fluid at the outer wall moves inward along the tube wall to replace the fluid ejected outwards. This results in the formation of two vortices symmetrical about a horizontal plane through the tube centre.

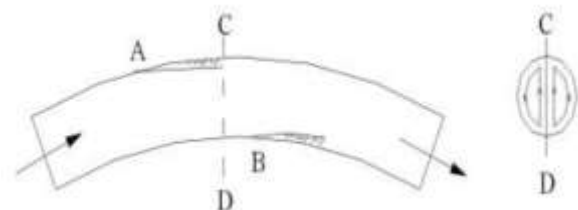

Fig.4 Secondary flow formation

In radial direction a pressure gradient is developed to create an acceleration, which acts towards the centre of the bend. The pressure at the outside of the pipe is more than the pressure at the inner side.

The increased pressure at the outside causes the velocity of the particle to decrease. This creates eddies Separation takes place at the outer wall. Separation and eddies also occur at point B on the inside of the bend, due to the inertia of the water. Moreover, the pressure which is very low at D increases as the point B approaches & adverse pressure exists. If radial section CD is taken across the bend, a secondary flow as shown in the Figure 3 is found to exist. Along the horizontal diameter CD, the pressure increases with the radial distance. But the pressure decreases as the low pressure region near the wall is approached. The difference in the pressure causes an outward motion along the wall from C to D. to satisfy the continuity condition, there is a flow from D to C along the radial direction. Thus a secondary flow is developed. This flow is in addition to the main flow which takes place along the axis of the pipe & a complex flow pattern occurs.

B. Classification of heat transfer enhancement techniques:

- 1) *Passive Techniques:* These techniques do not require any direct input of external power; rather they use it from the

system itself which ultimately leads to an increase in fluid pressure drop. They generally use surface or geometrical modifications to the flow channel by incorporating inserts or additional devices. They promote higher heat transfer coefficients by disturbing or altering the existing flow behavior except for extended surfaces. Heat transfer augmentation by these techniques can be achieved by using;

- i. **Treated Surfaces:** Such surfaces have a fine scale alteration to their finish or coating which may be continuous or discontinuous. They are primarily used for boiling and condensing duties.
 - ii. **Rough surfaces:** These are the surface modifications that promote turbulence in the flow field in the wall region, primarily in single phase flows, without increase in heat transfer surface area.
 - iii. **Extended surfaces:** They provide effective heat transfer enlargement. The newer developments have led to modified finned surfaces that also tend to improve the heat transfer coefficients by disturbing the flow field in addition to increasing the surface area.
 - iv. **Displaced enhancement devices:** These are the inserts that are used primarily in confined forced convection, and they improve energy transport indirectly at the heat exchange surface by displacing the fluid the heated or cooled surface of the duct with bulk fluid from the core flow.
 - v. **Swirl flow devices:** They produce and superimpose swirl flow or secondary recirculation on the axial flow in a channel. These include helical strip or cored screw type tube inserts,
 - vi. **twisted tapes.** They can be used for single phase and two-phase flows.
 - vii. **Coiled tubes:** These lead to relatively more compact heat exchangers. It produces secondary flows and vortices which promote higher heat transfer coefficients in single phase flows as well as in most regions of boiling.
 - viii. **Surface tension devices:** These consist of wicking or grooved surfaces, which direct and improve the flow of liquid to boiling surfaces and from condensing surfaces.
 - ix. **Additives for liquids:** These include the addition of solid particles, soluble trace additives and gas bubbles in single phase flows and trace additives which usually depress the surface tension of the liquid for boiling systems.
 - x. **Additives for gases:** These include liquid droplets or solid particles, which are introduced in single-phase gas flows either as dilute phase (gas-solid suspensions) or as dense phase (fluidized beds).
- 2) **Active Techniques:** In these cases, external power is used to facilitate the desired flow modification and the concomitant improvement in the rate of heat transfer.

Augmentation of heat transfer by this method can be achieved by:-

- i. **Mechanical Aids:** Such instruments stir the fluid by mechanical means or by rotating the surface. These include rotating tube heat exchangers and scrapped surface heat and mass exchangers. **Surface vibration:** They have been applied in single phase flows to obtain higher heat transfer coefficients.
 - ii. **Fluid vibration:** These are primarily used in single phase flows and are considered to be perhaps the most practical type of vibration enhancement technique.
 - iii. **Electrostatic fields:** It can be in the form of electric or magnetic fields or a combination of the two from dc or ac sources, which can be applied in heat exchange systems involving dielectric fluids. Depending on the application, it can also produce greater bulk mixing and induce forced convection or electromagnetic pumping to enhance heat transfer.
 - iv. **Injection:** Such a technique is used in single phase flow and pertains to the method of injecting the same or a different fluid into the main bulk fluid either through a porous heat transfer interface or upstream of the heat transfer section.
 - v. **Suction:** It involves either vapour removal through a porous heated surface in nucleate or film boiling, or fluid withdrawal through a porous heated surface in single-phase flow.
 - vi. **Jet impingement:** It involves the direction of heating or cooling fluid perpendicularly or obliquely to the heat transfer surface.
- 3) **Compound Techniques:** When any two or more of these techniques are employed simultaneously to obtain enhancement in heat transfer that is greater than that produced by either of them when used individually, is termed as compound enhancement. This technique involves complex design and hence has limited applications.

C. Geometry Of Shell And Coiled Tube Heat Exchanger

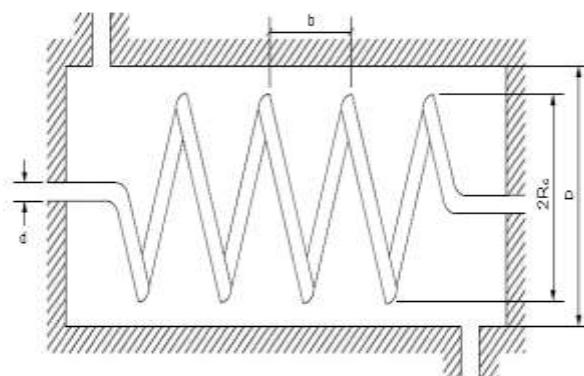

Fig no. 5 Schematic view of a typical shell and coiled tube heat exchanger

A typical shell and coiled tube heat exchanger is shown in Fig.5 in this figure, d is the diameter of the coiled tube, R_c is the curvature radius of the coil, D is the inner diameter of shell, and b is the coil pitch. The curvature ratio, d , is defined as the coil-to-tube diameter ratio, $d/2R_c$, and the non-dimensional pitch, c , is defined as $b/2(\pi)R_c$. The other four important dimensionless parameters of coiled tube namely, Reynolds number (Re_i), Nusselt number (Nu_i), Dean Number (De), and Helical number (He) are defined as follow:

1) *Reynolds number*: The Reynolds number can be defined for several different situations where a fluid is in relative motion to a surface. These definitions generally include the fluid properties of density and viscosity, plus a velocity and a characteristic length or characteristic dimension. This dimension is a matter of convention -For example, radius and diameter are equally valid to describe spheres or circles, but one is chosen by convention. For aircraft or ships, the length or width can be used. For flow in a pipe or a sphere moving in a fluid the internal diameter is generally used today. Other shapes such as rectangular pipes or non-spherical objects have an equivalent diameter defined. For fluids of variable density such as compressible gases or fluids of variable viscosity such as non-Newtonian fluids, special rules apply. The velocity may also be a matter of convention in some circumstances, notably stirred vessels. For flow in a pipe or tube, the Reynolds number is generally defined as:

$$Re = \frac{\rho v D}{\mu} = \frac{v D}{\nu} = \frac{Q D_H}{\nu A}$$

where,

- D_H is the hydraulic diameter of the pipe; its characteristic travelled length, L , (m).
- Q is the volumetric flow rate (m^3/s).
- A is the pipe cross-sectional area (m^2).
- v is the mean velocity of the fluid (SI units: m/s).
- μ is the dynamic viscosity of the fluid ($Pa \cdot s = N \cdot s/m^2 = kg/(m \cdot s)$).
- ν is the kinematic viscosity, $\nu = \frac{\mu}{\rho}$ (m^2/s).
- ρ is the density of the fluid (kg/m^3).

For shapes such as squares, rectangular or annular ducts where the height and width are comparable, the characteristic dimension for internal flow situations is taken to be the hydraulic diameter, D_H , defined as:

$$D_H = \frac{4A}{P}$$

2) *Nusselt Number*: In heat transfer at a boundary (surface) within a fluid the Nusselt number (Nu) is the ratio of convective to conductive heat transfer across (normal to) the boundary. In this context, convection includes both advection and diffusion. The convection and conduction heat flows are parallel to each other and

to the surface normal of the boundary surface, and are all perpendicular to the mean fluid flow in the simple case.

$$Nu_L = \frac{\text{Convective Heat Transfer}}{\text{Conductive Heat Transfer}} = \frac{hL}{k}$$

Where,

- L = characteristic length
- k = thermal conductivity of the fluid
- h = convective heat transfer coefficient of the fluid

3) *Dean number*: The Dean number (D) is a dimensionless group in fluid mechanics, which occurs in the study of flow in curved pipes and channels. The Dean number is typically denoted by the symbol D . For flow in a pipe or tube it is defined as:

$$D = \frac{\rho V d}{\mu} \left(\sqrt{\frac{d}{2R}} \right)$$

where,

- ρ is the density of the fluid
- μ is the dynamic viscosity
- V is the axial velocity scale
- d is the diameter (other shapes are represented by an equivalent diameter, see Reynolds number)
- R is the radius of curvature of the path of the channel.

The Dean number is therefore the product of the Reynolds number (based on axial flow V through a pipe of diameter d) and the square root of the curvature ratio.

4) *Prandtl Number*: The Prandtl number is a dimensionless number; the ratio of momentum diffusivity (kinematic viscosity) to thermal diffusivity.

It is defined as:

$$Pr = \frac{\nu}{\alpha} = \frac{\text{Viscous Diffusion Rate}}{\text{Thermal Diffusion Rate}} = \frac{C_p \mu}{k}$$

where,

- ν : kinematic viscosity, $\nu = \mu/\rho$, (m^2/s)
- α : thermal diffusivity, $\alpha = k/\rho C_p$, (m^2/s)
- μ : dynamic viscosity, ($Pa \cdot s = N \cdot s/m^2$)
- k : thermal conductivity, ($W/(m \cdot K)$)
- C_p : specific heat, ($J/(kg \cdot K)$)

II. EXPERIMENTAL SET-UP and FABRICATION

A. Experimental set-up

Fig no. 4.1 Setup diagram of shell and helical coil heat exchanger

1. Hot water storage
2. Centrifugal pump
3. Coil inlet rotameter
4. Shell
5. Helical coil
6. Shell outlet tank
7. Coil inlet thermometer
8. Shell outlet thermometer
9. Coil outlet thermometer
10. Shell inlet thermometer
11. Coil outlet tank
12. Shell inlet rotameter
13. Cold water storage

The schematic diagram of experimental set-up is shown in Fig 6. The set-up is a well instrumented single-phase heat exchanging system in which a hot water stream flowing inside the tube-side is cooled by a cold water stream flowing in the

shell-side. The main parts of the cycle are coiled tube heat exchanger, centrifugal pump, storage tank, and heater. The heat exchangers include a copper coiled tube and an insulated shell. The dimensions of the heat exchangers are depicted in Table. The water in storage tank is heated using an electric heater. Reaching to a prescribed temperature, pump is started to circulate the hot water in the cycle. A ball valve is used to control the flow rate of coolant water and hot water, respectively. To measure the flow rate of the cold stream/hot stream a rotameter is installed upstream of the heat exchanger. The inlet and outlet temperatures of hot and cold water were recorded manually using 4 glass alcohol thermometers inserted in the small holes made in the inlet and outlet tubes of each heat exchanger and sealed to prevent any leakage. Also, all the pipes and connections between the temperature measuring stations and heat exchanger were duly insulated.

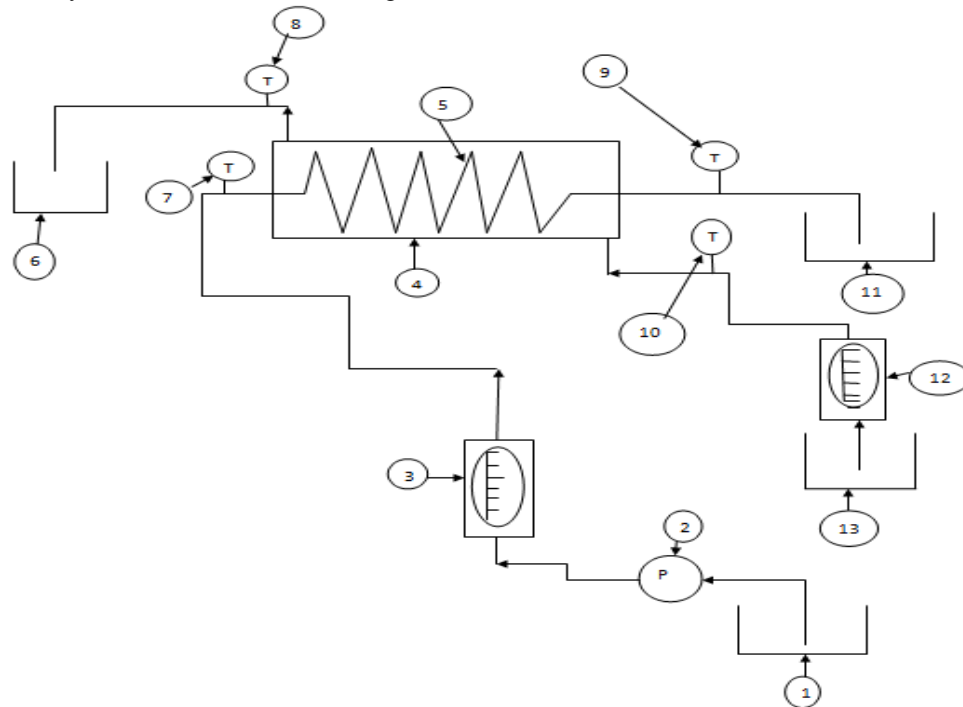

Fig no. 6 Setup diagram of shell and helical coil heat exchanger

B. Components

1. **Thermometer:**For temperature measurement of inlet and outlet of shell and coil we used alcohol glass thermometer of range -10 to 110 degree Celsius. For quick response and ease of reading we used this thermometer because red and white color gives contrast for ease of vision.
2. **Rotameter:**For flow measurement of inlet of helical coil (hot water) and inlet of shell (cold water) we used acrylic water rotameter of range 4 to 50 LPH.
3. **Electrical heater**
 Specifications
 - Wattage-3000 watts
 - Voltage-230 V AC/50 Hz
 For heating the inlet water to helical coil we used electrical heater. For maintaining the constant temperature we inserted thermostat inside the electrical heater.
4. **Pump: Pump Specification:**
 - Power - 5HP
 - Head - 15 meters
 - Speed - 2820 rpm
 - Discharge - 900 LPH
 - Volt - 240 V
5. **Helical coil**
 - Raw Material used - Copper tube.
 - Length of copper tube - 12ft
 - Quantity - 1
6. **Dimensions of coil**

TABLE 1
Dimensions of Coil

| ID | OD | Pitch | D _m | Shell Diameter |
|-------|-------|-------|----------------|----------------|
| 8.3mm | 9.8mm | 24mm | 55mm | 75mm |

7. Manufacturing of shell

TABLE 2
Manufacturing of Shell

| Component | Material |
|--------------|----------------------------------|
| helical coil | Copper(k=386 W/mK) |
| Shell | polyvinyl chloride(k=0.027 W/mK) |
| Insulation | Asbestos wool(k=0.046 W/mK) |
| End cap | polyvinyl chloride |

8. Quantity & specification

TABLE 3
Quantity & Specifications

| | |
|----------------------|-------|
| Hollow tube(shell) | 1 |
| Diameter of shell | 75mm |
| Length of shell | 1.5ft |
| End cap | 2 |
| Diameter of end cap | 80mm |
| Thickness of shell | 2mm |
| Thickness of end cap | 2.5mm |

9. Connection to coil & shell

For hot water connections to helical coils inside the shell we used flexible hose fitted with clips to avoid leakage. We joint all the connections at one junction with the help of nozzle, FT, pipe, elbow, T of UPVC (ultra poly vinyl chloride). We used ball valves to control the flow as desired (as shown in above figure in red color). For cold water connections through shell as like coil connections we used UPVC pipe and ball valves for controlling purpose .For avoiding heat losses we insulated all piping connection with asbestos rope.

III. CALCULATIONS

The data were collected for both coils. The operating parameter range is given in table. A different flow rate in tube-side and shell-side is taken for the counter flow configuration.

Tube-side heat transfer rate can be calculated as

$$Q_h = m_{hw} \times c_{pw} \times (T_{hi} - T_{ho}) \quad (1)$$

Shell-side heat transfer rate can be calculated as

$$Q_c = m_{cw} \times c_{pw} \times (T_{co} - T_{ci}) \quad (2)$$

The average heat transfer rate is calculated a

$$Q_{avg} = \frac{Q_h + Q_c}{2} \quad (3)$$

The log mean temperature difference (LMTD) is calculated as

$$LMTD = \frac{\Delta T_1 - \Delta T_2}{\ln\left(\frac{\Delta T_1}{\Delta T_2}\right)} \quad (4)$$

Where, $\Delta T_1 = T_{hi} - T_{co}$ $\Delta T_2 = T_{ho} - T_{ci}$

Then the overall heat transfer coefficient can be calculated by

$$U_o = \frac{Q_{avg}}{A_o LMTD} \quad (5)$$

The total convective area of the tube (πdL) for three helical coiled heat exchanger with circular pattern.

$$A_o = \pi d_i L_1$$

The overall heat transfer coefficient can be related to the inner and outer heat transfer coefficient from following equation,

$$\frac{1}{UA} = 1/A_i h_i + \frac{\ln(d_o/d_i)}{2\pi k L} + \frac{1}{A_o h_o} \quad (6)$$

Where, d_o is the outer diameter of the tube, d_i is the inner diameter of the tube, k is the thermal conductivity of the wall, and L is the length of the tube for both coil. After calculating overall heat transfer coefficient, only unknown variables are h_i and h_o convective heat transfer coefficient inner and outer side respectively.

Heat transfer for the shell-side and tube-side were calculated by Wilson plots. By keeping mass flow rate in the tube-side is constant and shell-side mass flow rate varying.

The outer heat transfer coefficient is calculated by,

$$Nu = c_1 Re^a Pr^b$$

Where, Nu is Nusselt Number, Re is Reynolds Number and Pr is Prandtl Number and the values of the constants are $a = 0.8$ and $b = 0.4$, the inside coefficient is given by

$$\alpha_i = c_1 (\lambda/d) Pr^{0.8} (\rho v d/\eta)^{0.8}$$

Where, λ is the fluid conductivity, d is the inside tube diameter, ρ is fluid density and η is fluid viscosity, and v is fluid velocity. Hence,

$$h_i = C_2 V^n \quad (7)$$

Where V is the tube-side fluid velocity m/sec. Substituting Eq. (7) into Eq. (6), the values for the constant, C , and the exponent, n , were determined through curve fitting. The outer and inner heat transfer could be calculated for all circular helical coil using Wilson plot method.

- Wilson plot method

One of the widely used methods for calculations of heat transfer coefficient is the Wilson plot technique. This approach was developed by E.E. Wilson in 1915 in order to evaluate the heat transfer coefficients in shell and tube condensers for the case of a vapour

condensing outside by means of a cooling liquid flow inside. It is based on the separation of the overall thermal resistance into the inside convective thermal resistance and the remaining thermal resistances participating in the heat transfer process. The overall thermal resistance R_{total} of the condensation process in a shell-and-tubes heat exchanger can be expressed as the sum of three constituent thermal resistances: R_{in} – the internal convection, R_{wall} – the tube wall and R_o – the external convection, presented in Eq.

$$R_{total} = R_{in} + R_{wall} + R_o \quad (8)$$

The thermal resistances of the fouling in Eq. (8) were neglected. Employing the expressions for the thermal resistances in Eq. (8), the overall thermal resistance can be rewritten as follows:

$$R_{total} = \frac{1}{h_i A_i} + \frac{\ln(d_o/d_i)}{2\pi k L} + \frac{1}{h_o A_o} \quad (9)$$

On the other hand, the overall thermal resistance can be written as a function of the overall heat transfer coefficient referred to the inner or outer tube surfaces and the corresponding areas. Assuming this the overall thermal resistance is expressed as a function of the overall heat transfer coefficient referred to the inner or outer surface $U_{i/o}$ and the inner or outer surface area $A_{i/o}$ (Eq. 10)

$$R_{total} = \frac{1}{U_{i/o} A_{i/o}} \quad (10)$$

Taking into account the specific conditions of a shell and tube condenser Wilson assumed that if the mass flow of the cooling liquid were modified, then the change in the overall thermal resistance would be mainly due to the variation of the in-tube heat transfer coefficient, while the remaining thermal resistances remained nearly constant. Therefore, as specified in Eq. (11) the thermal resistances outside of the tubes and the tube wall could be regarded as constant:

$$R_{wall} + R_o = C_1 \quad (11)$$

So, equation (9) was compared with a straight line

$$f(a, b) = a + bx \quad (12)$$

where $f(a, b) = R_{total}$

$$a = c_1$$

$$b = \frac{1}{C_2 A_i}$$

$$R_{ov} = \frac{1}{C_2 A_2} + \frac{1}{V^n} + C_1 \quad (13)$$

On the other hand, the overall thermal resistance and the cooling liquid velocity can be obtained by experimentally measuring the inlet temperature, the outlet temperature and at various mass flow rates

(kg/sec) of the cooling liquid under fully developed turbulent flow.

Then, for each set of experimental data corresponding to each mass flow rate, the overall thermal resistance is the ratio between the logarithmic mean temperature differences of the fluids (LMTD).

The heat flow is determined from the enthalpy change of the cooling liquid as given in (Eq. (13))

$$R_{ov} = \frac{LMTD}{m_1 C_{p1} (T_{co} - T_{oci})} \quad (14)$$

From here, the straight-line equation that fits the experimental data can be deduced by applying simple linear regression. Then, the values of the constants C1 and C2 calculated

In practice, the vertical offsets from a line (polynomial, surface, hyperplane, etc.) are almost always minimized instead of the perpendicular offsets. This provides a fitting function for the independent variable X that estimates Y for a given x (most often what an experimenter wants), allows uncertainties of the data points along the x - and y -axes to be incorporated simply, and also provides a much simpler analytic form for the fitting parameters than would be obtained using a fit based on perpendicular offsets. In addition, the fitting technique can be easily generalized from a best-fit line to a best-fit polynomial when sums of vertical distances are used. In any case, for a reasonable number of noisy data points, the difference between vertical and perpendicular fits is quite small.

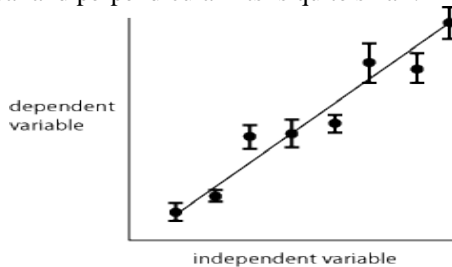

Fig. 7 Straight line regression

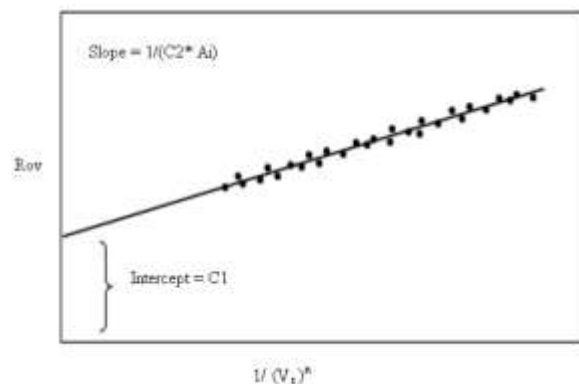

Fig 8 Wilson plot method

Vertical least squares fitting proceeds by finding the sum of the squares of the vertical deviations of a set of data points

$$R^2 = \sum [y_i - f(x_i, a_1, a_2, \dots, a_n)]^2$$

from a function f . Note that this procedure does not minimize the actual deviations from the line (which would be measured perpendicular to the given function). In addition, although the unsquared sum of distances might seem a more appropriate quantity to minimize, use of the absolute value results in discontinuous derivatives which cannot be treated analytically. The square deviations from each point are therefore summed, and the resulting residual is then minimized to find the best fit line. This procedure results in outlying points being given disproportionately large weighting.

The condition for R^2 to be a minimum is that

$$\frac{\partial(R^2)}{\partial a_i} = 0$$

For $i=1,2,3,\dots,n$. For a linear fit,

$$f(a,b) = a + bx$$

so,

$$\frac{\partial(R^2)}{\partial a} = -2 \sum_{i=1}^n [y_i - (a + bx_i)] = 0$$

$$\frac{\partial(R^2)}{\partial b} = -2 \sum_{i=1}^n [y_i - (a + bx_i)] x_i = 0 \quad (15)$$

As a result, the mean value of the convection coefficient outside the tubes (mean value of the outside thermal resistance) and the convection coefficient inside the tubes can be estimated as a function of the velocity of the cooling liquid

The four important dimensionless parameters of coiled tube namely, Reynolds Number (Re), Nusselt Number (Nu), Dean Number (De), and Helical Number (He) are defined as follow

$$\text{Reynolds Number (Re)} = \frac{\rho V d_i}{\mu} \quad (16)$$

$$\text{Nusselt Number (Nu)} = \frac{h d_i}{k} \quad (17)$$

Dean number (De) = Reynolds Number x Curvature

Ratio

$$De = Re \times (d_i / 2Rc)^{0.5}$$

$$\delta = (d_i / 2Rc) \quad De = Re \times \delta^{0.5} \quad (18)$$

$$\text{Helical Number (He)} = [De / (1 + \gamma^2)^{0.5}] \quad (19)$$

$$\text{Dimensionless Pitch } (\gamma) = (b / 2\pi Rc) \quad (20)$$

b = pitch of the coil

Curvature Ratio (δ) is ratio of tube diameter to the coil diameter measured from tube axis.

$$\delta = (r / R) \quad (21)$$

Where, r is tube radius and R is coil radius.

$$\text{Prandtl no. (Pr)} = \frac{\mu C_p}{k} \quad (22)$$

The suitable use of heat transfer knowledge in the design of practical heat transfer equipment is an art. Designers must be constantly aware of the differences between the idealized conditions under which the fundamental knowledge was obtained and the real conditions of their design and its environment.

IV. ANALYSIS

The graph overall Nusselt number. vs. Reynolds no. shows heat transfer rate for different flow rates of cold water in shell. The value of Nusselt no. and Reynolds no. are all readings for different flow rates. The graph shows as coolant velocity increases the slope of the graph increases. This implies that if the flow rate of coolant is increased, the rate of increase of Nusselt no. with Reynolds no. increases. The heat transfer coefficient increases with increase in Reynolds no. as Nusselt no. increases

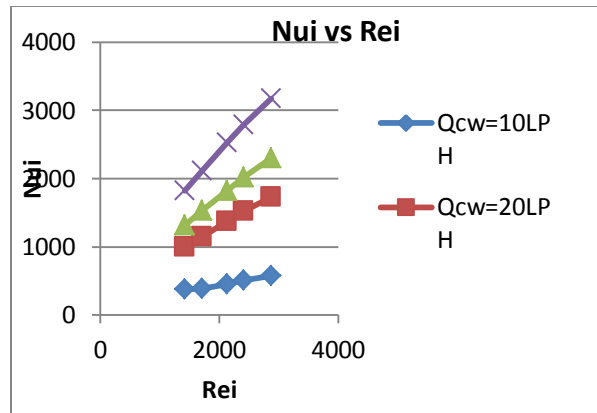

Fig. 9 Graph between nusselt number and reynolds number

The graph overall tube side heat transfer coefficient vs Reynolds no. shows heat transfer rate for different flow rates of cold water in shell. The value of heat transfer coefficient. and Reynolds no. are all readings for different flow rates of coolants. The graph shows as coolant velocity increases the slope of the graph increases. This implies that if the flow rate of coolant is increased, the rate of increase of heat transfer coefficient with Reynolds no. increases. The heat transfer coefficient increases with increase in Reynolds no.

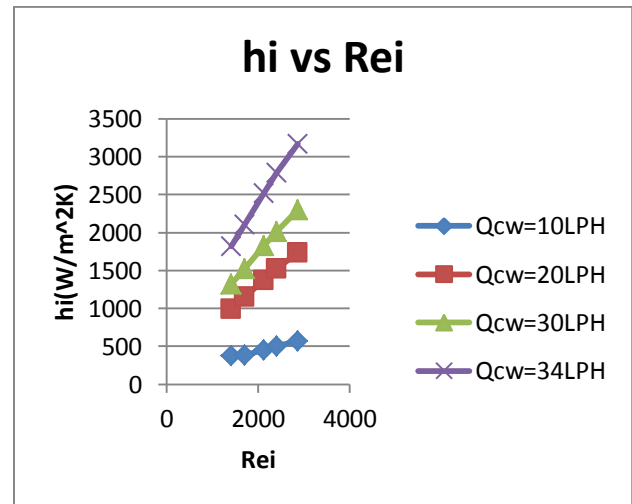

Fig. 10 Graph between convective heat transfer coefficient and Reynolds number

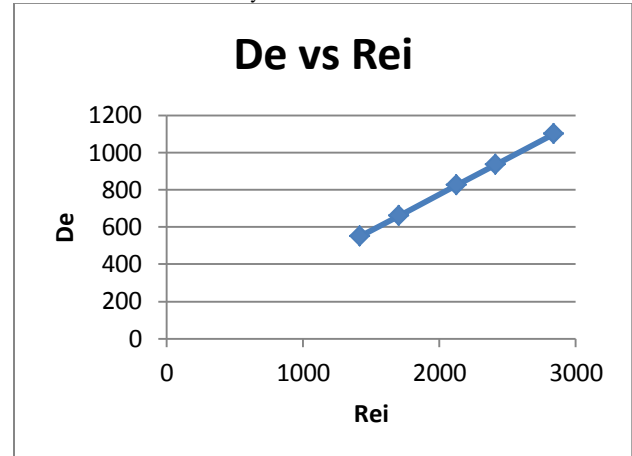

Fig. 11 Graph between Dean number and Reynolds number

The graph Dean number vs. Reynolds number shows a linear variation. Dean number is the property of fluid flowing in curved tubes and shells which signifies the extent of turbulence due to secondary flow. Greater will be the turbulence higher will be the heat exchange. As the Dean no. is increasing with increase in Reynolds no. so, the heat transfer rate will also increase with the Reynolds number.

The graph Dean number vs. Nusselt number shows variation of Nusselt no. of tube side at

different flow rate of hot water in the helical tube with relative Dean number .Dean number is the property of fluid flowing in curved tubes and shells which signifies the extent of turbulence due to secondary flow. Greater will be the turbulence higher will be the heat exchange. Nusselt number is directly proportional to the heat transfer coefficient ,so the increase in Dean no. result in increase in Nusselt number. The graph also shows Nui vs. De graph for different flow rate of cold water . the slope of curve is larger for the higher flow rate of cold water

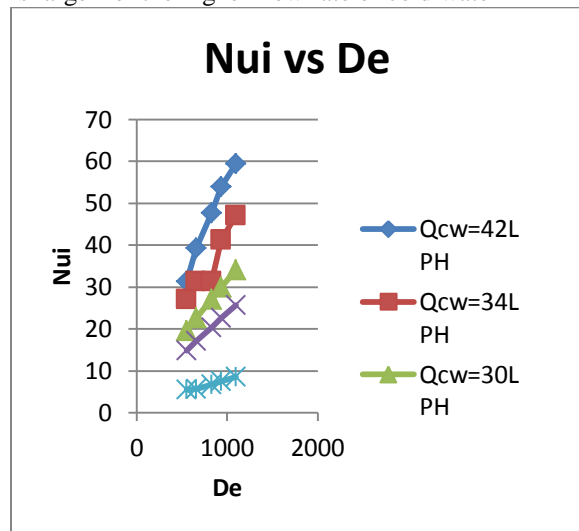

Fig. 12 Graph between Nusselt Number and Dean number

V. RESULTS

This project presents a comparative analysis of the different correlations given by the different researchers for helical coil heat exchanger. The various equations use different parameters for the analysis .It was found that the centrifugal force due to the curvature of the tube results in the secondary flow development which enhances the heat transfer rate. This phenomenon can be beneficial especially in laminar flow regime. The overall effect of these parameters on Nu and h_i is presented in this paper. The analysis shows that, for low Re, the graphs of Nu Vs Re and h_i Vs Re is steeper than that at high Re. It indicates that helical coils are efficient in low Re. As well as the graph shows as coolant velocity increases the slope of the graph increases. This implies that if the flow rate of coolant is increased, the rate of increase of heat transfer coefficient with Reynolds number increases.

VI. CONCLUSION

A. The graph overall Nusselt number. vs. Reynolds no. shows heat transfer rate for different flow rates of cold water in shell . The value of Nusselt no. and Reynolds no. are all readings for different flow rates. The graph shows as coolant velocity increases the slope of the graph increases. This implies that if the flow rate of coolant is increased, the rate of increase of Nusselt no. with Reynolds

no. increases. The heat transfer coefficient increases with increase in Reynolds no. as Nusselt no. increases.

- B. The graph overall tube side heat transfer coefficient vs Reynolds no. shows heat transfer rate for different flow rates of cold water in shell . The value of heat transfer coefficient. and Reynolds no. are all readings for different flow rates of coolants . The graph shows as coolant velocity increases the slope of the graph increases. This implies that if the flow rate of coolant is increased, the rate of increase of heat transfer coefficient with Reynolds no. increases. The heat transfer coefficient increases with increase in Reynolds no.
- C. The graph Dean number vs. Reynolds number shows a linear variation .Dean number is the property of fluid flowing in curved tubes and shells which signifies the extent of turbulence due to secondary flow. Greater will be the turbulence higher will be the heat exchange. As the Dean no. is increasing with increase in Reynolds no. so, the heat transfer rate will also increase with the Reynolds number.
- D. The graph Dean number vs. Nusselt number shows variation of Nusselt no. of tube side at different flow rate of hot water in the helical tube with relative Dean number .Dean number is the property of fluid flowing in curved tubes and shells which signifies the extent of turbulence due to secondary flow. Greater will be the turbulence higher will be the heat exchange. Nusselt number is directly proportional to the heat transfer coefficient ,so the increase in Dean no. result in increase in Nusselt number. The graph also shows Nui vs. De graph for different flow rate of cold water . the slope of curve is larger for the higher flow rate of cold water.

REFERENCES

- [1] Salimpour M. R., "Heat transfer Coefficients of shell and coiled tube heat exchangers", Experimental Thermal and Fluid science, 2009.
- [2] W. Wichayanuwat and S. Kheawhom, "Heat Transfer Coefficients for Particulate Airflow in Shell and Coiled Tube Heat Exchangers", World Academy of Science, Engineering and Technology, 2009.
- [3] Ramesh K. Shah and Dušan P. Sekulic, "*Fundamentals of Heat Exchanger Design*", John Wiley & Sons, Inc.
- [4] Ranjit Gouda & Amit Bikram Das, "Some experimental studies on heat transfer augmentation for flow of liquid through circular tubes using twisted angles and tapes", Department of chemical engineering national institute of technology Rourkela, 2008
- [5] Tomasz Sobota Cracow , "Experimental Prediction of Heat Transfer Correlations in Heat Exchangers", University of Technology, Poland.
- [6] Nasser Ghorbani , Hessem Taherian , Mofid Gorji , Hessem Mirgolbabaei , "An experimental study of thermal performance of shell-and-coil heat exchangers2010.
- [7] John W. Rose , "Heat-transfer coefficients, Wilson plots and accuracy of thermal ",measurements",Experimental Thermal and Fluid Science, 2004.
- [8] C. Y. WANG;J.",On the low-Reynolds-number flow in a helical pipe", Fluid Me, 1981.