

Static Analysis of Crane Hook with T-Section Using Ansys

M.N.V Krishnaveni¹, M.Amareswari Reddy², M RajaRoy³

^{1,2,3}ANITS, Department of Mechanical Engineering, Andhra University, Visakhapatnam-531162

Abstract—Crane hooks are highly liable components that are typically used for industrial purposes. Failure of a crane hook mainly depends on three major factors i.e. dimension, material. In this paper load carrying capacity is studied by varying the cross sections. The selected sections are Circular, Trapezoidal and T-section. The area remains constant while changing the dimensions for the four different sections. The crane hook is modeled using SOLIDWORKS software. The stress analysis is done using ANSYS 14.0 workbench Educational version. It is found that T cross section yields minimum stresses at the given load of 6ton for constant cross section area among three cross sections. The stress distribution pattern is verified for its correctness on model of crane hook using Winkler-Bach theory for curved beams.

Keywords — Crane hook, Static analysis, Winkler-Bach theory, ANSYS 14.0.

I. INTRODUCTION

Crane Hooks are highly responsible components that are typically used for handling material in industries. It is basically a hoisting fixture designed to engage a ring or link of a lifting chain or the pin of a shackle or cable socket and must follow the health and safety guidelines. Thus, the aim of the work is to study the stress distribution pattern of a crane hook using finite element method and to verify the results using scathing method.

The lifting of material generally occurs on construction sites, in factories and other industrial situations. Correct lifting can move large objects efficiently and reduce manual handling operations. Improper design of crane hook lead to disastrous accidents. Every year, incorrect lifting procedures cause injuries, loss of work time and property. People, machinery, loads, methods and the work environment, are all important factors for correct lifting. Provided that enough safety measures are fully implemented, lifting accidents can be reduced. The Fig 1.1 as shows the general diagram of crane hook.



Fig 1.1 Crane Hook

2. LITERATURE REVIEW

Crane hooks are the components which are generally used to elevate the heavy load in industries and constructional sites. Recently, excavators having a crane-hook are widely used in construction works site. One reason is that such an excavator is convenient since they can perform the conventional digging tasks as well as the suspension works. Another reason is that there are work sites where the crane trucks for suspension work are not available because of the narrowness of the site. In general an excavator has superior manoeuvrability than a crane truck. However, there are cases that the crane hooks are damaged during some kind of suspension works. From the view point of safety, such damage must be prevented. Identification of the reason of the damage is one of the key points toward the safety improvement. If a crack is developed in the crane hook, mainly at stress concentration areas, it can cause fracture of the hook and lead to serious accidents. In ductile fracture, the crack propagates continuously and is more easily detectable and hence preferred over brittle fracture. In brittle fracture, there is sudden propagation of the crack and the hook fails suddenly. This type of fracture is very dangerous as it is difficult to detect.

AjeetBergaley and AnshumanPurohit [1] described their work on structural Analysis of Crane Hook Using Finite Element. Crane hook are highly significant component used for lifting the load with the help of chain or links. Crane hook is purchased from the local market for finite element analysis. The hook was tested on the UTM machine in tension to locate the area having maximum stress and to locate the yield point. The model of hook is prepared in CAE software having dimension and material similar to the crane hook which was purchased from the market. The results obtained were compared with theoretical analysis. Then cross section in which minimum stress induced for given load was modified through FEM.

A.Gopichand [2] carried an optimization of design parameters for crane hook using Taguchi method. Crane hooks are one of the important components which are used to transfer materials having heavy loads, mainly in industries. Crane hooks are liable components subjected to failure due to stress in accumulation of heavy loads. The design parameters for crane hook are area of cross section, material and radius of crane hook. In the present work optimization of design parameters is carried out using Taguchi method, total three parameters are considered with mixed levels and L16 orthogonal array is generated. The optimum combination of input parameters for minimum Vonmises stresses are determined.

Rashmi Uddanwadikerin [3] discussed on stress analysis of crane hook and validation by photo-elasticity. Crane hooks are highly liable components and are always subjected to failure due to accumulation of large amount of stresses which can eventually lead to its failure. To study the stress pattern of crane hook in its loaded condition, a solid model of crane hook is prepared with the help of CMM and CAD software. Real time pattern of stress concentration in 3D model of crane hook is obtained. The stress distribution pattern is verified for its correctness on an acrylic model of crane hook using Diffused light Polari scope set up. By predicting the stress concentration area, the shape of the crane is modified to increase its working life and reduce the failure rates.

III DESIGN OF CRANE HOOK

Machine frames having curved portions are frequently subjected to bending or axial loads or to a combination of bending and axial loads. With the reduction in the radius of curved portion, the stress due to curvature become greater and the results of the equations of straight beams when used becomes less satisfactory. For relatively small radii of curvature, the actual stresses may be several times greater than the value obtained for straight beams. It has been found from the results of Photo elastic experiments that in case of curved beams, the neutral surface does not coincide with centroidal axis but instead shifted towards the Centre of curvature. It has also been found that the stresses in the fibers of a curved beam are not proportional to the distances of the fibers from the neutral surfaces, as is assumed for a straight beam. The design of crane hook was done by taking the data pertaining to load(w), C.S.A and curvatures which are used in industrial applications of crane hook

3.1 Theoretical Design of Crane Hook with T C.S.A

Considering the dimensions of the JCB's crane hook at Kommadi, Visakhapatnam. P=6 Ton = 58860 N; R₁=60.625 mm; R₃=139.375 mm; H = 80 mm; b₁=80 mm; b₂=40mm t₁=20 mm t₂=60 mm with these values we done a modeling in SOLIDWORKS with T cross section.

Taking sectional constant h² for T-section, based on Winkler- Batch theory

$$h^2 = \frac{R^3}{A} \left[\left\{ b_2 \log_e \left(\frac{R_3}{R_2} \right) + \left(b_1 \log_e \left(\frac{R_2}{R_3} \right) \right) \right\} \right] - R^2$$

$$h^2 = \frac{93.97^3}{3980} \left[\left\{ 40 \log_e \left(\frac{139.375}{80} \right) + \left(80 \log_e \left(\frac{80}{60.625} \right) \right) \right\} \right] - 93.97^2$$

$$= 424.75 \text{ mm}^2$$

Total equivalent stress, $\sigma = \sigma_0 + \sigma_b$

Direct stress due to load,

$$\sigma_0 = \frac{P}{A} = \frac{58860}{3980} = 14.788 \text{ N/mm}^2$$

Bending stress due to load,

$$\sigma_b = \frac{-M}{A \times R} \left[1 + \frac{R^2}{h^2} \left(\frac{y}{R+y} \right) \right]$$

Here the moment due to load is taken negative sign as the load straightening curvature of hook, M = P × R
Total Stress at Inner layer of the hook is maximum, since both are of tensile in nature

$$\sigma_{\max} = 14.788 - 14.788 \left[1 + \frac{93.97^2}{424.75} \left(\frac{-33.97}{93.97 - 33.97} \right) \right]$$

$$= 174.07 \text{ N/mm}^2$$

Total Stress at Outer layer of the hook is minimum, since both are stresses are of opposite in nature

$$\sigma_{\min} = 14.78 - 14.788 \left[1 + \frac{93.97^2}{424.75} \left(\frac{46.03}{93.97 + 46.03} \right) \right]$$

$$= -101.085 \text{ N/mm}^2$$

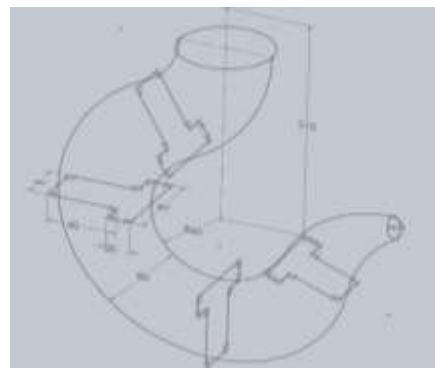

Fig 3.1 Design of Crane Hook with T C.S.A

3.2 Theoretical Design of Crane Hook with Circular C.S.A

Considering the same cross sectional area as of T-section for circular cross section. P = 6 Ton = 58860 N; R_i= 60 mm; R_o= 131.18 mm; d=71.18mm with these values we done a modeling in SOLIDWORKS with circular cross section.

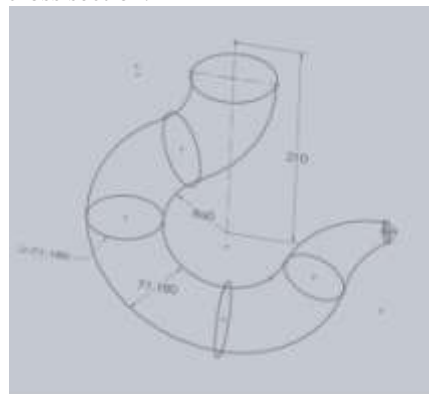

Fig 3.2 Design of Crane Hook with Circular C.S.A

Total equivalent stress, $\sigma = \sigma_0 + \sigma_b$

Direct stress due to load,

$$\sigma_0 = \frac{P}{A} = \frac{58860}{3980} = 14.788 \text{ N/mm}^2$$

Bending stress due to load,

$$\sigma_b = \frac{M}{A \times R} \left[1 + \frac{R^2}{h^2} \left(\frac{y}{R+y} \right) \right]$$

Taking sectional constant h^2 for circular section, based on Winkler- Batch theory

$$h^2 = \frac{d^2}{16} + \frac{1}{128} \frac{d^4}{R^2}$$

$$= \frac{71.18^2}{16} + \frac{1}{128} \frac{71.18^4}{95.59^2}$$

$$h^2 = 338.61 \text{ mm}^2$$

$$\sigma_{b(\text{outer})} = -14.788 \left[1 + \frac{95.59^2}{338.61} \left(\frac{35.59}{95.59 + 35.59} \right) \right]$$

$$= -123.065 \text{ N/mm}^2$$

$$\sigma_{b(\text{inner})} = -14.788 \left[1 + \frac{95.59^2}{338.61} \left(\frac{-35.59}{95.59 - 35.59} \right) \right]$$

$$= 221.935 \text{ N/mm}^2$$

Maximum stress in hook is

$$\sigma_{\text{max}} = 14.788 + 221.935 = 236.723 \text{ N/mm}^2$$

Minimum stress in hook is

$$\sigma_{\text{min}} = 14.788 - 123.065 = -108.277 \text{ N/mm}^2$$

3.3 Theoretical Design of Crane Hook with Trapezoidal C.S.A

Considering same cross sectional area as of T-section for Trapezoidal cross section. $P = 6 \text{ Ton} = 58860 \text{ N}$; $R_1 = 60 \text{ mm}$; $R_2 = 140 \text{ mm}$; $H = 80 \text{ mm}$; $b_1 = 70 \text{ mm}$; $b_2 = 36 \text{ mm}$ with these values we done a modeling in SOLIDWORKS with Trapezoidal cross section.

$d_1 = 36.12 \text{ mm}$ (From Solid works data)

$$d_2 = H - d_1 = 80 - 36.12 = 43.88 \text{ mm}$$

$$R_1 = 60 \text{ mm}$$

$$R_2 = 140 \text{ mm}$$

$$R = 60 + 36.12 = 96.12 \text{ mm}$$

Total equivalent stress, $\sigma = \sigma_0 + \sigma_b$

Direct stress due to load,

$$\sigma_0 = \frac{P}{A} = \frac{58860}{3980} = 14.788 \text{ N/mm}^2$$

Bending stress due to load,

$$\sigma_b = \frac{-M}{A \times R} \left[1 + \frac{R^2}{h^2} \left(\frac{y}{R+y} \right) \right]$$

Taking sectional constant h^2 for Trapezoidal section, based on Winkler-Batch theory

$$h^2 = \frac{R^3}{A} \left[\left\{ b_2 + \frac{(b_1 - b_2)R_2}{h_1} \right\} \ln \left(\frac{R_2}{R_1} \right) - (b_1 - b_2) \right. \\ \left. + \left\{ b_3 + \frac{(b_2 - b_3)R_3}{h_2} \right\} \ln \left(\frac{R_3}{R_2} \right) - (b_2 - b_3) \right. \\ \left. + \left\{ b_4 + \frac{(b_3 - b_4)R_4}{h_3} \right\} \ln \left(\frac{R_4}{R_3} \right) - (b_3 - b_4) \right] - R^2$$

$$= \frac{96.12^3}{3980} \left[\left\{ 62 + \frac{(47 - 62)81.74}{21.74} \right\} \ln \left(\frac{81.74}{60} \right) - (47 - 62) \right. \\ \left. + \left\{ 40 + \frac{(62 - 40)130.49}{48.75} \right\} \ln \left(\frac{130.49}{81.74} \right) - (62 - 40) \right. \\ \left. + \left\{ 26 + \frac{(40 - 26)140}{9.51} \right\} \ln \left(\frac{140}{130.49} \right) - (40 - 26) \right] - 96.12^2$$

$$= 223.13[1.732 + 15 + 46.255 - 22 + 16.33 - 14] - 9239.05$$

$$= 426.27 \text{ mm}^2$$

Maximum stress in hook is,

$$\sigma_{\text{max}} = 14.788 - 14.7888 \left[1 + \frac{96.12^2}{426.27} \left(\frac{-36.12}{96.12 - 36.12} \right) \right]$$

$$= 192.965 \text{ N/mm}^2$$

Minimum stress in hook is,

$$\sigma_{\text{min}} = 14.788 - 14.788 \left[1 + \frac{96.12^2}{426.27} \left(\frac{43.88}{96.12 + 43.88} \right) \right]$$

$$= -100.466 \text{ N/mm}^2$$

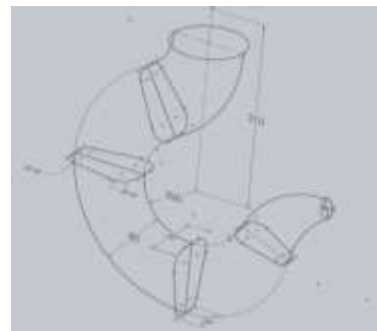

Fig 3.3 Design of Crane Hook with Trapezoidal C.S.A

IV MODELLING OF CRANE HOOK USING SOLIDWORK

Building a model in SOLIDWORKS usually starts with a 2D sketch (although 3D sketches are available for power users). The sketch consists of geometry such as points, lines, arcs, conics (except the hyperbola), and splines. Dimensions are added to the sketch to define the size and location of the geometry. Relations are used to define attributes such as tangency, parallelism, perpendicularity, and concentricity. The parametric nature of

SOLIDWORKS means that the dimensions and relations drive the geometry, not the other way around. The dimensions in the sketch can be controlled independently, or by relationships to other parameters inside or outside of the sketch.

In an assembly the relations are mates. Just as sketch relations define conditions such as tangency, parallelism, and concentricity with respect to sketch geometry, assembly mates define equivalent relations with respect to the individual parts or components, allowing the easy construction of assemblies. SOLIDWORKS also includes additional advanced mating features such as gear and cam follower mates, which allow modelled gear assemblies to accurately reproduce the rotational movement of an actual gear train.

Finally, drawings can be created either from parts or assemblies. Views are automatically generated from the solid model, and notes, dimensions and tolerances can then be easily added to the drawing as needed. The drawing module includes most paper sizes and standards (ANSI, ISO, DIN, GOST, JIS, BSI and SAC).

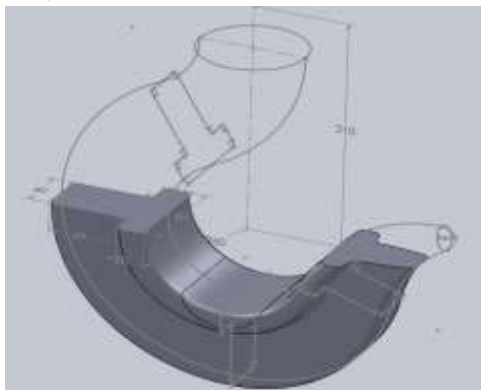

Fig 4.1 Solidworks Model of Crane Hook with T-section

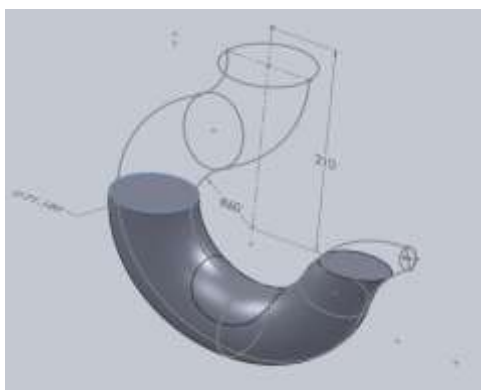

Fig 4.2 Solidworks Model of Crane Hook with Circular-section

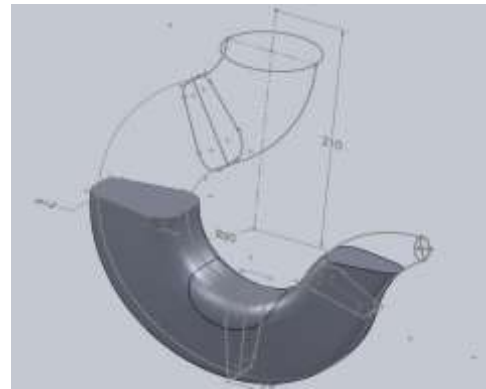

Fig 4.3 Solidworks Model of Crane Hook with Trapezoidal -section

V FINITE ELEMENT ANALYSIS OF CRANE HOOK USING ANSYS WORKBENCH

The finite element method has become a dominant tool for the numerical solution of wide range of engineering problems. Applications range from deformation and stress analysis of automotive aircraft, building, and bridge structures with advances in computer technology and CAD systems, complex problems can be modelled with relative alleviate.

In this method of analysis, a complex region defining a continuum is discretized into simple geometric shapes called finite elements. The material properties and the governing relationships are considered over these elements and considering the loading and constraints, results in a set of equations. Solution of these equations gives us the approximate behaviour of the continuum.

VI RESULTS AND DISCUSSION

In this paper Three sections of crane hooks are designed according to curved beam concept. Stresses are found for 6 Ton load using curved beam concept.

Total model is modeled in SOLIDWORKS and IGES model is imported in to ANSYS, here top side of hook is fixed and at the inner curvature of hook 58860 N (6 Ton) load is applied on nodes and stresses and deformation are plotted.

Table 6.1 Properties Materials taken for FEA of crane hook

	ASTM Grade 60 (Grey cast iron)	Carbon Steel (SAE-AISI 1040)
Density (Kg/m ³)	7200	7800
Young's modulus	–	210

(GPa)		
Strength to weight ratio	57 to 60	71 to 81
Tensile strength-Yield (MPa)	276	320 to 530
Tensile strength-Ultimate (MPa)	410 to 430	550 to 630
Thermal Expansion (Base 22°C)	10.5	11.9

6.1 ASTM Grade 60 (Grey Cast Iron)

6.1.1 Circular cross section

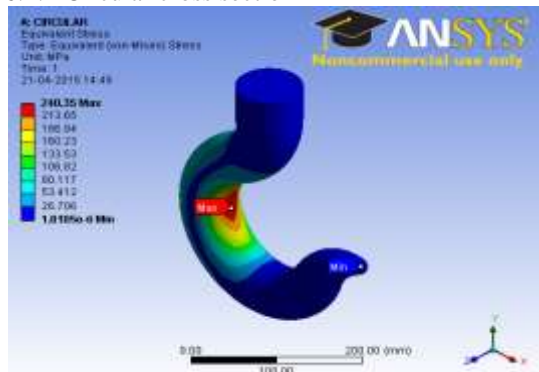

Fig 6.1(a) Equivalent stresses in Circular-Section

6.1.2 Trapezoidal cross section

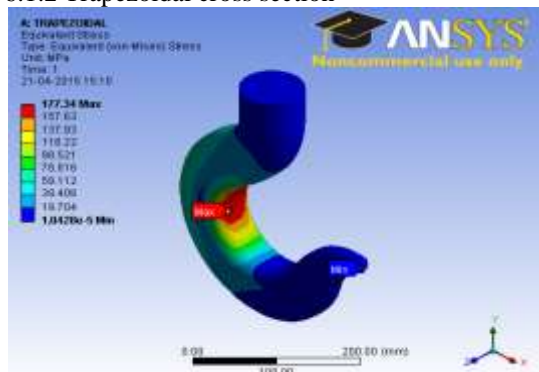

Fig 6.1(b) Equivalent stresses in Trapezoidal-Section

6.1.3 T-section

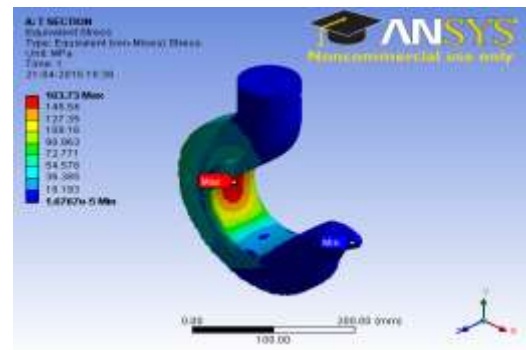

Fig 6.1(c) Equivalent stresses in T-Section

6.2 Carbon Steel

6.2.1 Circular cross section

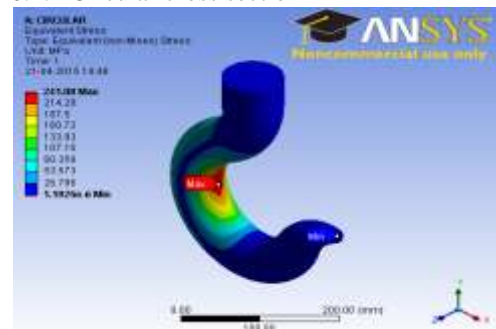

Fig 6.2(a) Equivalent stresses in Circular-Section

6.2.2 Trapezoidal section

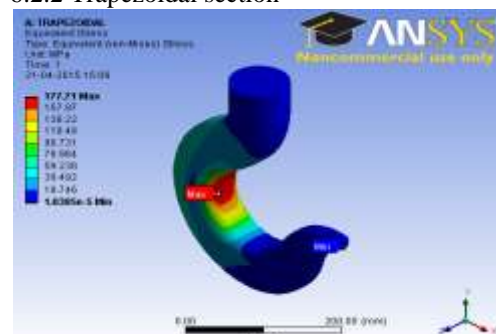

Fig 6.2(b) Equivalent stresses in Trapezoidal-Section

6.2.3 T-section

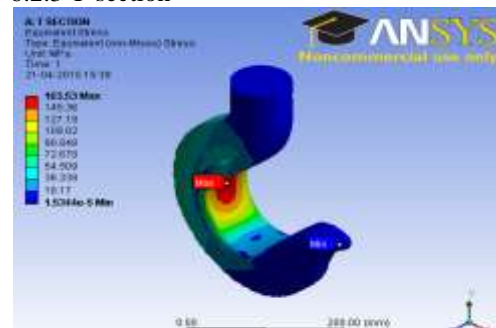

Fig 6.2(c) Equivalent stresses in T-Section

6.3 Values of Maximum Stresses in Different Cross Sections of Crane hook

Table 6.1 Comparison of Stresses in Different Cross Sections

SECTION NAME	AREA OF CROSS SECTION (mm ²)	INNER RADIUS OF CURVATURE (mm)	LOAD (Ton)	THEORETICAL STRESS (N/mm ²)	ANSYS STRESS (N/mm ²)	ANSYS STRESS (N/mm ²)
CIRCULAR	3980	60	6	236.723	241.08	240.35
TRAPEZOIDAL	3980	60	6	192.965	177.71	177.34
T-SECTION	3980	60	6	174.07	163.53	163.73

Theoretical stresses calculated based on Winkler-Batch theory and the corresponding crane hook model stresses determined by using ANSYS were tabulated as shown above and found that the deviations are at minimum of 5%. The factor of safety for crane hook under static analysis is 2 based on yield stress value.

VII CONCLUSION

Three types of crane hooks are designed according to curved beam concept and the induced stresses were determined by Winkler-Batch theory. Total three models are prepared in CAD software (SOLIDWORKS) and imported into ANSYS. Stresses and deformation values are noted from ANSYS software. Theoretical stresses and ANSYS values are compared and deviation is at minimum of 5%. For 6 Ton loading the stresses induced in Circular, Trapezoidal and T-section of Carbon steel and Grey cast iron are below the allowable stresses. The stresses induced in the T section are less than the other sections for same area of cross section and loading. It concludes that T section of Carbon steel offers good results for optimal crane hook design.

VIII REFERENCES

[1] AjeetBergaley and AnshumanPurohitdescribed their work on “Structural Analysis of Crane Hook Using Finite Element” International Journal of Science and Modern Engineering (IJSME) ISSN: 2319-6386, Volume-1, Issue-10, September 2013
 [2] A.Gopichand carried an optimization of design parameters for “Crane Hook Using Taguchi Method” International Journal of Science and Modern Engineering (IJSME) ISSN: 2319-8753 An ISO 3297: 2007 Certified Organization Vol. 2, Issue 12, December 2013
 [3] RashmiUddanwadikerin discussed on “Stress Analysis of Crane Hook and Validation by Photo-Elasticity” International Journal of

Engineering Research & Technology ISSN: 2278-0181 Vol.3 - Issue 1 (January - 2014)

[4]Chetan N. Benkar explained the “Finite Element Stress Analysis of Crane Hook with Different Cross Sections” International Journal for Technological Research in Engineering ISSN (Online): 2347 – 4718 Volume 1, Issue 9, May-2014

[5] Ismail Gerdemeli, G. U. Rajurkar, Dr. D. V. Bhope, Prof. S. D. Khamankar explained the “Finite Element Analysis of the Tower Damage which Occurs Due to Heavy Loads” International Journal of Engineering Research & Technology ISSN: 2278-0181 Vol.2 - Issue 8 (August -2013)

[6] ShyamLal Sharma, Tasmeem Ahmad Khan, Md. Parvez and KamleshKumariexperimented on “Design of Hoisting Arrangement of E.O.T. Crane (2008) International Journal of Engineering & Robotics Research ISSN 2278 – 0149 Vol. 2, No. 3, July 2013

[7] Santosh Shaun, Ritesh Dewangan, ManasPatnaik and NarendraYadav describes the “Study of Crane Hook Having Trapezoidal Section by Finite Element Method & Design of Experiments” International Journal of Modern Engineering Research (IJMER)ISSN: 2249-6645 Vol.2, Issue.4, July-Aug 2012 PP-2779-2781

[8] Takuma Nishimura, Takao Muromakiet, Kazuyuki Hanahara, Yukio Tada, Shigeyuki Kuroda and Tadahisa Fukui “Damage Factor Estimation of Crane-Hook (A Database Approach with Image, Knowledge and Simulation)”, 4th International Workshop on Reliable Engineering Computing (REC 2010).

[9] E. Narvydas, N. Puodziuniene, “Circumferential stress concentration factors at the asymmetric shallow notches of the lifting hooks of trapezoidal cross-section”, ISSN 1392 - 1207. Mechanika. 2012 Volume 18(2): 152-157.