

# Microcontroller Based Smart Card Car Security System

A. Z. Loko<sup>1</sup>, A. I. Bugaje<sup>2</sup>, Usman Abdullahi<sup>3</sup>

<sup>1</sup>Department of Physics Electronics/Nasarawa State University Keffi P.MB 1022, Nigeria

<sup>2</sup>National Space Research and Development Agency, Abuja Nigeria

<sup>3</sup>AU Electronics, Zoo Road Kano

**Abstract** - This paper focuses on the design and implementation of a microcontroller based smart card car security system with call intrusion alert capability. A PIC16F877A microcontroller, RFID reader, RFID card and a GSM modem were used for the successful implementation of the system. The PIC16F877A microcontroller was used to serve as the entire brain of the system which holds the unique RFID card number and controls the electromagnetic relay and the GSM MODEM. The Electromagnetic relay served as the mechanical tool that secures the car ignition system, and the GSM modem was used to call the car owner whenever there is an intrusion attempt. Consequently, with this kind of system presented in this paper, the security of our automobiles can be more sensitive in order to secure and protect our automobiles more from any intrusion and theft in an electronic based approach. The system designed was tested under different case scenarios to verify its reliability.

**Index term** - PIC16F877A, GSM MODEM, Electromagnetic Relay, RFID

## 1.0 Introduction

Today, most vehicles are equipped with high tech security systems in order to mitigate the menace of car theft and hijacking. Similarly, the keyless remote control system, GPS tracking devices [6], voice recognition devices [7], GSM based devices [3],[4] and passive RFID [1] are among the most common technologies used in safe guarding automobiles. Furthermore, the most common security technique used in cars is the keyless car central locking system; however it has not proved to providing a complete vehicle security in theft case scenarios. Consequently, the aim of the system presented in this paper is to design and implementation of a microcontroller based smart card car security system with call intrusion alert capability. An RFID reader and RFID smart card 125kHz are used for providing a unique wireless radio frequency identification, PIC16F877A microcontroller was used to serve as the entire brain of the system which holds the unique RFID card number and controls the electromagnetic relay and the GSM MODEM. The Electromagnetic relay served as the mechanical tool that secures the car ignition system, it

closes immediately the right card is scanned on the RFID reader and remains open whenever the wrong card is scanned thereby controlling the car ignition and the GSM modem was used to call the car owner whenever there is an intrusion attempt.

## 2.0 PROPOSED SYSTEM

Figure 1 show the entire proposed system block diagram where the PIC16F877A microcontroller stores the right smart card unique radio frequency identification numbers. Whenever the scanned card corresponds with the stored unique card number, the microcontroller gives signal to the electromagnetic relay to close so as to give the user the chance to start the vehicle ignition. For an invalid smart card, the microcontroller gives the user three consecutive chances and if failed, the microcontroller commands the GSM modem to call the car owner's cellular phone as his phone number is also stored in the PIC16F877 microcontroller.

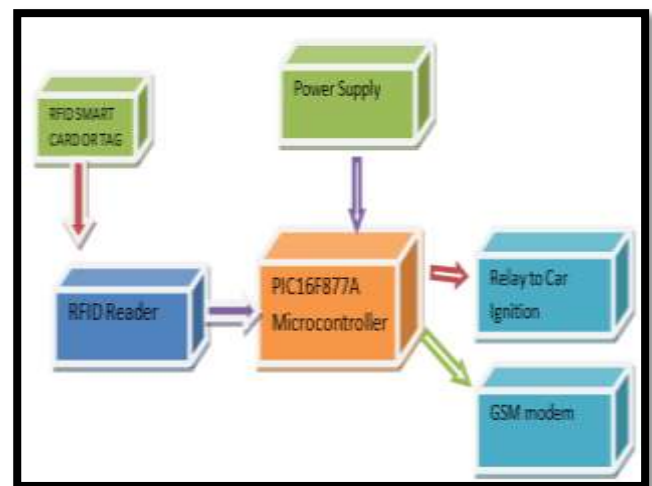

Figure1 Proposed System

## 2.1. Main Controller

The main control section was built with the PIC16F877A microcontroller IC. The PIC16F877A microcontroller belongs to the Microchip Company, which is an 8-bit microcontroller with up to 8 channels built in A/D converter, built in transmitter-receiver module and 40 I/O pins [8]. The microcontroller IC

monitors and controls the entire system's operation. The PIC16F877A microcontroller stores the right smart card unique radio frequency identification numbers. Whenever the scanned card corresponds with the stored unique card number, the microcontroller gives signal to the electromagnetic relay to close so as to give the user the chance to start the vehicle ignition. For an invalid smart card, the microcontroller gives the user three consecutive chances and if failed, the microcontroller commands the GSM modem to call the car owner's cellular phone as his phone number is also stored in the PIC16F877 microcontroller.

## 2.2. Electromagnetic Relay

An **electromagnetic relay** is a switching device which closes and opens whenever a small electric current is connected to it. When a current is passed through its coil, the mechanical switch moves close and opens when otherwise. The relay in this project is used to switch on the car ignition system whenever right card is scanned [9]

## 2.3 Radio Frequency Identification (RFID)

RFID is a technology that helps to identify the living or non-living through radio waves [10]. A typical RFID system consists of a reader and transponder [11]. RFID is a leading automatic identification technology. RFID tags communicate information by radio wave through antennae on small computer chips attached to objects so that such objects may be identified, located, and tracked [12]. The RFID in this project is used to provide the unique identification number which serves as the security authorization number used by the microcontroller to allow the ignition system of the vehicle to start or not based on the scanned smart RFID Card.



125 kHz RFID reader and Card

## 2.4. GSM MODEM

The **GSM MODEM** allows the microcontroller to communicate over the mobile network through calls, SMS and MMS messages. It consists of a SIM card and operates over a subscription through a mobile network. It is a highly flexible plug-and-play device capable of connecting to a PC or any

microcontroller's serial port through MAX232IC. This IC is used to convert the TTL logic levels of the microcontroller to a RS232 logic level for enabling serial communication. [13]. Therefore, the GSM modem is used in this system to call the car owner whenever the invalid card is scanned in three consecutive attempts.



SIM900A GSM module

## 3.0 SYSTEM FLOWCHART

This is used to represent a flow of sequential events which when implemented through the controller via the C programming language, will bring about the *smart card car security system* with call intrusion alert. From the below in flow chart diagram, the program starts by initializing the ports and the UART. Subsequently, the code enters the while (1) and waits until a string of card number is received by the microcontroller UART. Whenever the received card number is the same with the stored card number in the Microcontroller ROM, the microcontroller energizes a relay on to switch ON the car ignition system at the same time call the car owner to let him know that his car is switch ON and if otherwise the relay remains off. The code gives the user three consecutive chances to scan in case of wrong card and when the chances elapse, the microcontroller commands the GSM to call the car owner's cellular phone using the ATD command (i.e. ATDnumber or ATD08101560149), thereby making the system really autonomous and better over the keyless car remote control system.

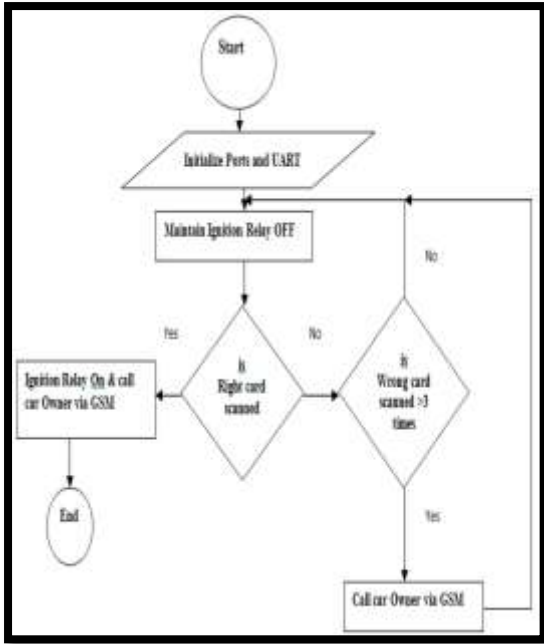

Figure 2 System flowchart

#### 4.0 HARDWARE AND SOFTWARE DESIGN AND IMPLEMENTATION

##### Complete schematic diagram

The circuit section consists of PIC16F877A microcontroller; 5V power supply circuit for relay circuit and the 125 kHz RFID reader.

The microcontroller receives string of scanned card number read by the RFID reader via the microcontroller's universal synchronous and asynchronous reception and transmission module. The microcontroller compares the received card number and the stored card number available in the microcontroller's ROM. Whenever the received card number is the same with the stored card number in the Microcontroller ROM, the microcontroller energise a relay on to switch ON the car ignition system at the same time call the car owner to let him know that his car is switch ON and if otherwise the relay remains off. The code gives the user three consecutive chances to scan in case of wrong card and when the chances elapse, the microcontroller commands the GSM to call the car owner's cellular phone using the ATD command (i.e. ATDnumber or ATD08101560149), thereby making the system really autonomous and better over the keyless car remote control system.

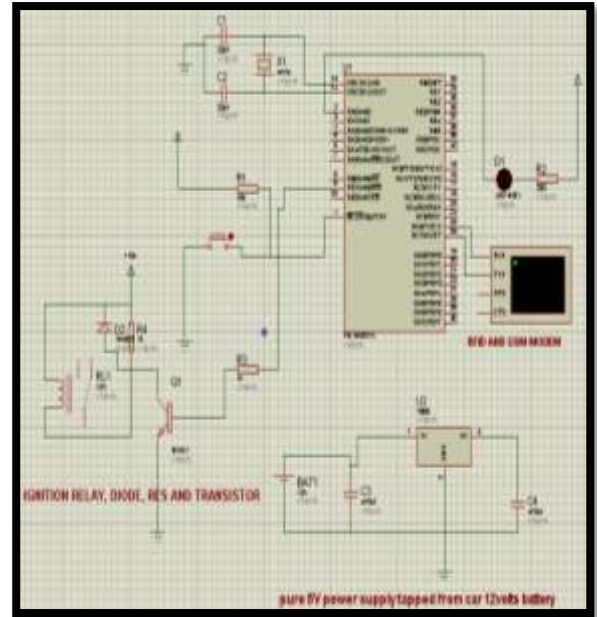

Figure 3 Complete schematic

#### 5.0 RESULTS

In order to verify the performance of the proposed microcontroller based smart card car security system, a hardware prototype was implemented with PIC16F877A microcontroller with a 4MHz crystal oscillator. During this test, a 1997 UK Honda civil was used for real time scenario testing which gave us the chance to analyse, observe, and test the efficiency of the system in different case conditions. The validity of this project prototype is verified through this test process.

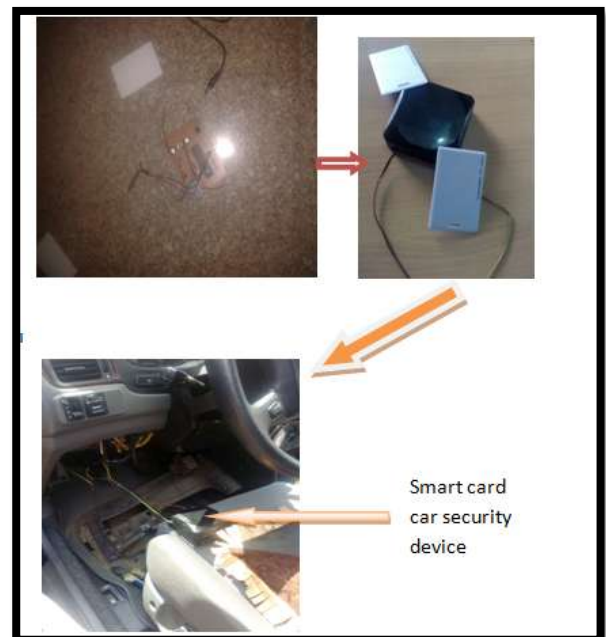

Figure 4 Smart-Card Car security

## **6.0 CONCLUSION AND FUTURE RECOMMENDATION**

### **6.1 Conclusion**

This paper presents a technical overview on the implementation of a microcontroller based smart card car security system with call intrusion capability. The system has proven to be more advanced than the conventional keyless remote control security because one has to scan the right card before the car ignition starts and also it calls the owner on his cellular phone whenever the car is started or whenever there is intrusion attempts in case of wrong card scanned.

### **6.1 Future Recommendation**

For future works, some recommendations have been listed in order to improve the performance.

#### **Use of GSM modem for wireless communication**

Using GSM module to wirelessly switch off the car engine in cases of out-smarting the card security system, thus the user can send text “Off” to switch the car engine

#### **Use of GPS modem for wireless communication**

Using GPS to be sending the car location continuously to the owner’s cellular phone for easy tracking of the vehicle in theft scenarios

## **Reference**

- [1] Rudy T. Sanders, Lee Fleishman., 1987. “User identifying vehicle control and security device”, United States Patent 4754255, May 14, 1987
- [2] Robert Bosch GmbH, 2001., “Device for protecting a motor vehicle against theft “, United States Patent 6856044. Nov 7, 2001
- [3] Alfredo J. Berard, James L. Mentzer, David C. Nixon., 1994. “Cellular/GPS system for vehicle tracking “, United States Patent 5515043, : August 17, 1994
- [4] Eliezer A. Sheffer, Marco J. Thompson.,1992. “Vehicle tracking system “, United States Patent 5218367, June 1, 1992
- [5] Paul-Andre Roland Savoie, Andre Eric Boulay., 1996,” Vehicle tracking system using cellular network”, United States Patent 5895436, April 26, 1996
- [6] Auto-Trac Inc., 1992. “Vehicle tracking and security system “, United States Patent 5223844. April 17, 1992
- [7] Voice Control Systems Inc., 1998. ”Speech controlled vehicle alarm system”, United States Patent 5706399. Jun 3, 1996. [8] RF Solutions Ltd., 2004.” Dual Band FM Wireless Transceivers“, June 200404
- [8] PIC 16F876A, February 2012 [Online]. Available: <http://www.microchip.com/wwwproducts/Devices.aspx>
- [9] Relays, June 2015 [Online] Available at <http://www.explainthatstuff.com/howrelayswork.html>
- [10] Hideki Imai, Mohammad Ghulam Rahman, Kazukuni Kobara. “Wireless Communications Security,” Artech House, Inc. 2008.
- [11] Paris Kitsos, Yan Zhang, “RFID Security Techniques, Protocols and System-on-Chip Design, .Springer” RFID Fundamentals and Applications. pp .3-27, 40-62; 2008.
- [12] Nakrop Jinaporn, Sodsai Wisadsud, Prasit Nakonrat, Atipong Suriya, “Security System against Asset Theft by using Radio Frequency Identification Technology,”. Proceedings of ECTI-CON. 2008.

[13] GSM based home security system working with application website <https://www.elprocus.com/gsm-based-home-security-system-working-with-applications/>