

Design and Sensitivities Analysis on Automotive Bumper Beam Subjected to Low Velocity Impact

Dr. S.Srinivasa Rao¹, K.Viswatej², Dr. S. Adinarayana³
Associate Professor¹, M-Tech Machine Design², Professor³
Department of Mechanical Engineering MVRGCE
Chintalavalasa, Vizianagram, A.P., India

Abstract:-

Designing a car bumper beam and successive analysis on how it affects the parameters such as shape, thickness and materials will help in enhancing the beam strength at the same time brings a reduction in weight. This also provides a way of using materials that are recyclable and biodegradable which help in controlling environmental pollution. In this paper, main parameters considered are shape, thickness, material and collision conditions, are premeditated for the analysis on an automotive bumper beam to enhance the properties of the beam particularly to stand against the impact forces of crash, ranging from medium speed to high speed impact collisions. Analysis on the bumper beam is performed on composites and conventional materials such as steel, aluminum and magnesium and comparison of the results of the impact behavior of the bumper beam are studied. This study is centered on the selection of bumper beam under varying parameters such as shape and material to cater the needs of safety during the stage of product design specification (PDS).

From this work, it had been observed that simple C-section has less stress values than that of other cross-section studied in this research. In the case of double C-section is observed that the stress values are a bit more than the simple C-section but the strain energy is increased by 4.5%. Impact analysis have been performed and compared their results with analytical results.

1. Introduction:-

The design of the beam, the energy absorbers [1] and the longitudinal members which form the front part and also their connection to the car and even the shapes of the beam define the capability of the front structure of the car in withstanding a crash [2]. Accidents are happening every day, according to the statistics that were given by NHTSA, ten thousand dead and hundreds of thousands to million wounded each year. There were

numbers of calls raised for the necessity to improve the safety of automobiles during accidents. Automotive bumper system is one of the key systems in automobiles which helps to protect the vehicle during collisions [4].

Bumper beam absorbs the impact force which is the kinetic energy of the beam due to motion by deforming. And this deformation is seen in both high speed impact conditions and also in low speed impact conditions. The safety conventions from E.C.E U. N AGREEMENT, REGULATION NO. 42 [2], 1994 placed few benchmark regulations for passenger's safety. The basic design criteria for the bumper beam is, "Under the speed of 2.5 kmph, the bumper beam should perform same as before and after the collision. Some more safety conventions, such as "low-speed and high to medium speed impacts and also everyday pedestrian impacts" along with "environmental restrictions" increased the complexity of bumper design. Proposed bumper design is feasible to create a reduction in weight at the same time stay intact in low-speed impact (for pedestrian safety) [3] and is also tough enough to dissipate the impact forces in high speed impact.

2. Bumper Beam:-

Bumper beam forms the basic structural member of the bumper system which is attached to the front portion of the vehicle chassis. It also acts as a safety method which protects the car and passengers from low to medium speed collisions by deflection. Under high speed collision it protects the passengers by deforming. The bumper system is design for the prevention for the reduction of physical damage in the front-end as well as rear-end collisions. The design of bumper should be made in such a way that it should protect the hood, trunk, grille in low speed collisions and fuel, exhaust and cooling system in medium and high speed collisions. Apart from these safety related equipment such as parking lights, headlamps³ and taillights should also stay away from damage during collisions. The

impact regulations to check the bumper performance are: Canadian Motor Vehicle Safety Regulation (CMVSR), ECE Regulation No-42, and National Highway Traffic Safety Administration (NHTSA) - Code 49 Part 58 [4].

3. Basic design procedure:-

3.1. Product design specification:-

The national highway traffic safety administration (NHTSA) proposed standards for bumper design for light passenger vehicle. These standards are the basic criteria those are to be satisfied for designing the bumper system, which generates the Product design specification. They are, [3]

- a) The front bumper as well as rear bumper on passenger cars should avert damage to the car body.
- b) Components like radiator, headlamps etc. which are placed immediately after the Bumper should work same as before and after the impact.
- c) Car bumper should withstand impact forces due to a 2.5 kmph crash into vehicle which is parked.
- d) Bumper should be placed 16 inches to 20 inches overhead surface of the road.

All bumpers must satisfy the above standards. A case study by a European car manufacturer trails the safety parameters of a bumper. [1]

- Impact test at low speed: Impact test on longitudinal pendulum by 4 kmph, and corner pendulum impact test by 1.0 kmph with bumper visual, functional, and safety damages.
- Impact test at high speed: No bumper damage or yielding after 8 kmph (full impact) frontal impact into a flat, rigid barrier.

3.2. Parameters that effect energy absorption in bumper beam design:-

Bumper beam at the basic level is considered as a simply supported beam. It is fixed to the front chassis to absorb impact forces caused by collisions. Five methods exist for the assembly of bumper system to automobile chassis for energy absorption during crash. In the present study, bumper beam was placed after the cover and mounted to the chassis by energy absorbers. Also there are various parameters which effect energy absorbing capability of the bumper beam. Which are:

- (a) Curvature of front chassis
- (b) Stress concentration
- (c) Fixing method
- (d) Strengthen rib
- (e) Material properties
- (f) Cross-section
- (g) Manufacturing method
- (h) Thickness. This work focused on the parameters like thickness, cross-section, material and supports.

Bumper Material Basic Requirements [5]

- a. It should absorb the accidental kinetic energy.
- b. It should have high strength.
- c. It should have good corrosion resistance.
- d. Light in weight.
- e. Low cost.
- f. Easy to manufacture in large quantity.

4. Collision Mechanics:-

There is a considerable importance for studying the collision mechanics. There are three different types of collision mechanism. 1) Elastic 2) plastic and 3) partially elastic/ elasto-plastic collision.

During an elastic collision, a miniscule amount of energy from two impacting bodies is lost. To take an example let us consider the following situation “when two billiard ball collide with each other the impact force of them converted in to elastic energy and again converted to kinetic energy. And a very few amount of energy is lost”. If we apply same phenomenon to the car bumper impact problem, when bumper collide with an impactor, the energy first converted to elastic energy of both systems and re-bounce them apart.

Unlike elastic collision in a plastic collision a substantial amount of energy is lost in the collision. That means when a bumper beam is collided with an impactor, major part of the energy is converted in to deformation energy. But, practically both of the above Phenomenon are not applicable, therefore the third mechanism comes in to the picture, which is named partially elastic collision also called as elasto-plastic collision. In which, a significant amount of energy is dissipated, however it ranges from the lower value of the plastic collision to the higher value of elastic collisions. This is the practical scenario where the bumper beam is subjected to... When the bumper is collided with an impactor, a part of energy is converted in to deformation energy, and the remaining part of energy is constitute the absorption energy along the re-bouncing energy. The kinetic energy before (K_i) and after (K_f) of above mechanisms are given in below table:-

Table 1 Kinetic energy conversion of different mechanisms

S.NO	CONDITION
Elastic Collision	$K_i=K_f$
Plastic Collision	$K_i<K_f$
Partially Elastic	$K_i<K_f$ and $\Delta K= K_i-K_f$

In this case, the impacting phenomenon that occurs between an impactor and bumper in a low-speed as well as high-speed full crash could be very

complicated owing to the nonlinear as well as transient analysis involved. In designing the front bumper, manufacturers contend that the bumper should not have any failure in terms of material as well as crash. So till that point, the total energy is conserved throughout the impact duration.

The impactor is supposed to be rigid. As the bumper beam was made mainly from metals and composite materials when it is subjected to impact load it undergoes a constant deformation δ_{max} . From the principle “law of conservation of energy” in the elastic impact is; the kinetic energy before impact is converted to elastic energy, and the kinetic energy of the impactor and the bumper is at its maximum deflection, i.e.,

$$E = \frac{1}{2}m_1v_1^2 + \frac{1}{2}m_2v_2^2 + \frac{1}{2}keq\delta_{max}^2 \quad (1)$$

Eqn (1) governs the impact mechanism under the elastic impact, where the m_1 and m_2 are the masses of the collision bodies and v_1 and v_2 are the velocities before and after collision, E represents the energy (K.E) of the system. The above equation will convert into Eqn (2) by replacing the energy, mass, and velocity, i.e.,

$$\frac{1}{2}m_A v_A^2 = \frac{1}{2}m_A v_0^2 + \frac{1}{2}m_B v_B^2 + \frac{1}{2}keq\delta_{max}^2 \quad (2)$$

where m_A is the impactor mass, m_B is automobile mass, v_A is impactor's velocity before impact and v_0 the final velocity of the impactor and the complete deflection of bumper beam is observed.

Considering momentum it should be noted that it can be neither be created nor destroyed. Therefore we have that momentum before and after impact stay the same. At the instant of the beam's maximum deflection, the principle of momentum conservation before and after impact can be expressed as follows:

$$m_A v_A = (m_A + m_B)v_0 \quad (3)$$

From the equations (1) and (2) the maximum deflection δ_{max} is obtained as follows:

$$\delta_{max}^2 = \frac{1}{k_{eq}} \frac{m_A m_B}{m_A + m_B} v_A^2 \quad (4)$$

After separation, both momentum as well as energy conservation can be expressed mathematically as:

$$\frac{1}{2}m_A v_A^2 = \frac{1}{2}m_A v_{A2}^2 + \frac{1}{2}m_B v_{B2}^2 \quad (5)$$

$$m_A v_A^2 = m_A v_{A2}^2 + m_B v_{B2}^2 \quad (6)$$

Where v_{A2} is the final velocity of impactor and v_{B2} is the final velocity of car at separation point. In the partially plastic impact, the principle of momentum conservation is satisfied since impact forces are equal and opposite.

$$m_A v_A^2 + m_B v_B^2 = m_A v_{A2}^2 + m_B v_{B2}^2 \quad (7)$$

In this case Coefficient of Restitution (COR) is used to determine the velocities after the collision. COR is the ratio of separation speed to that of approach speed in a collision.

In the case of a perfectly elastic collision,

Velocity of separation = velocity of approach.

In the case of perfectly inelastic collision.

Velocity of separation = 0

In general, the bodies are neither perfectly elastic nor perfectly inelastic. In that case we can write,

Velocity of separation = e (velocity of approach).

Where $0 < e < 1$. The constant e depends on the materials of the colliding bodies. This constant is known as coefficient of restitution.

$$e = \frac{v_{B2} - v_{A2}}{v_A - v_B} \quad (8)$$

When COR equals to 1 we have elastic collision but when COR equals to 0 we have plastic collision which is effectively sticking to the object after collision with, not bouncing at all. The COR is a value which shows how much K.E (energy of motion) is sustained even after the collision of two objects. If the coefficient is 1 or very near to 1, it suggests that little energy was lost during the collision. If COR is approaching zero or equal to 0, it shows that a considerable amount of energy was lost during the collision in this case it is transformed into absorption energy to deform the bumper beam.

The below mathematical can be used to ascertain the energy dissipated, E_D , during the collision.

$$E_{plastic} = \frac{1}{2}m_A v_A^2 + \frac{1}{2}m_B v_B^2 - \frac{1}{2}m_A v_{A2}^2 - \frac{1}{2}m_B v_{B2}^2 \quad (9)$$

5. Modeling and Analysis:-

To study how the parameters like thickness, cross-section and materials will affect the performance of the bumper beam, an existing bumper beam is modeled and analyzed, both by analytically and with F.E.M tool (ANSYS 15.0). The modeling is done in

the solid modeling software (creo-2.0). The dimensions of the bumper beam is shown in fig 2.

The thickness of this bumper beam is 2 mm. The material used for manufacturing this bumper beam and its properties are mentioned in bellow table 1.

Table 1 Material properties of steel

Young's Modulus	Poisson's Ratio	Density	Yield Strength
210 GPa	0.3	7850 kg/m ³	380 Mpa

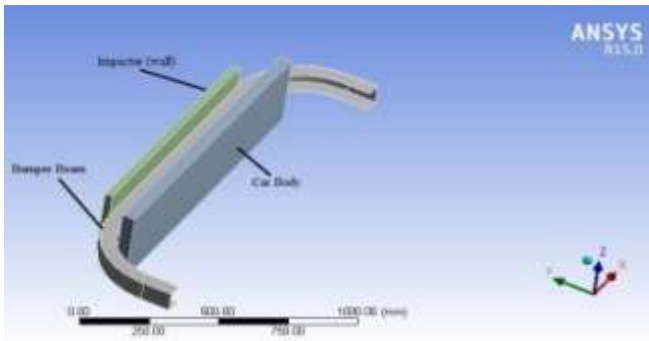
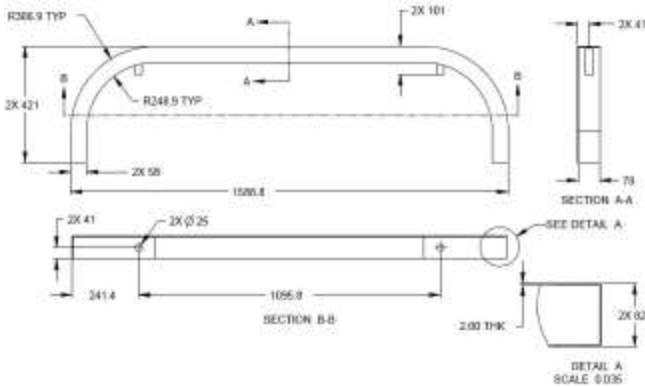

Fig 1. Bumper beam and the impactor



The analytical solution of such impact problem is accomplished by applying classical dynamics theories. At first, the bumper can be assumed as a simple support beam with both the ends fully constrained

Fig 2. Detail Drawing of the bumper beam as shown in the fig 3.

From mechanics of materials, the bending stiffness of such beam is $48 EI/L^3$ as external loads are applied on its center.



Table 2 Physical properties of steel bumper of 2 mm thickness

Effective length L (mm)	Moment of inertia I (mm ⁴)	Bending stiffness (N/mm)
1096	1.38219 x 10 ⁵	1058.27

Since we are considering that the bumper beam is colliding with the impactor, the impact force that generated due to the collision, is taken as point load acting with a constant magnitude.

The maximum bending moment for the bumper beam is $= \frac{wl}{4} = 2956727.43$ N-mm.

Then the bending stress will be

$$\sigma_b = \frac{M \cdot y}{I} = 379.53 \text{ N/mm}^2$$

5.2 FINITE ELEMENT ANALYSIS:-

Bumper beam is analyzed in ANSYS 15.0 by importing the system in to the work bench. Analysis had been performed on the beam both in statics and in dynamics.

5.2.1. Statics:-

In the case of the statics the impact problem have to convert to an equivalent structure of the bumper beam system. Defining the boundary conditions and loading conditions are the important parameters. First of all we have to define the material properties like mass density, young's modulus and Poisson's ratio. The loading conditions are calculated as follows:-

5.2.1.1. Input data:

Mass of the car with bumper =1554 kg, Speed of the car = 2.5kmph

Assume this car is hitting at another identical one and it will stop in 0.1 seconds.

Deceleration of the car = 7 m/s², Force acted during collision =10.8 KN

For the easiness of calculation this force is converted into a pressure which is acted on the front surface of the modeled bumper.

Area of the front face of bumper =79950 mm²

Pressure acted on the bumper = 0.136 N/mm²

Pressure of 0.136 Mpa is applied on bumper beam. The results of the analysis is tabulated in table 3.

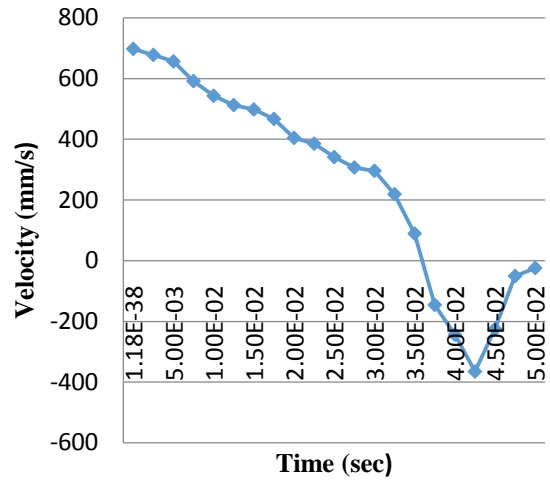
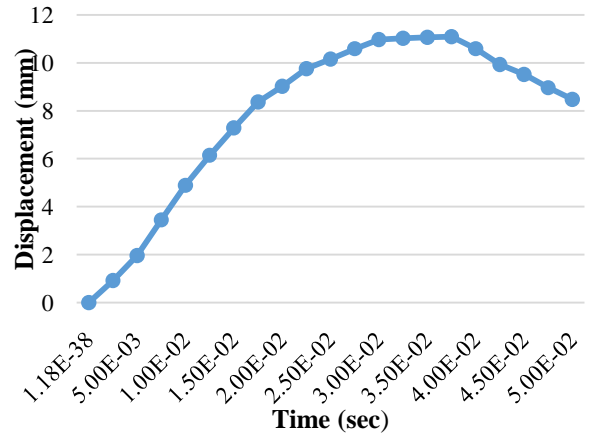
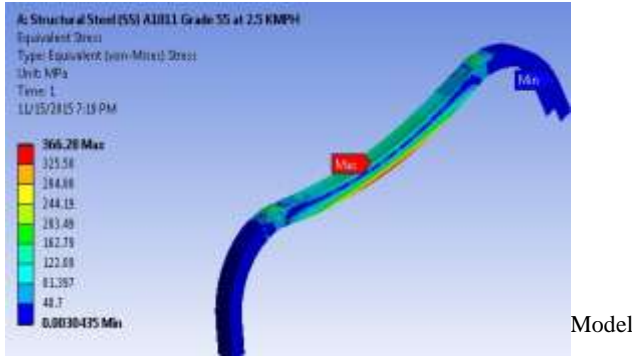

Fig 6 (c). Displacement of the bumper beam in Statics

Fig 6 (e) Velocity vs. Time graph of the Steel bumper beam at the impact of 2.5 kmph

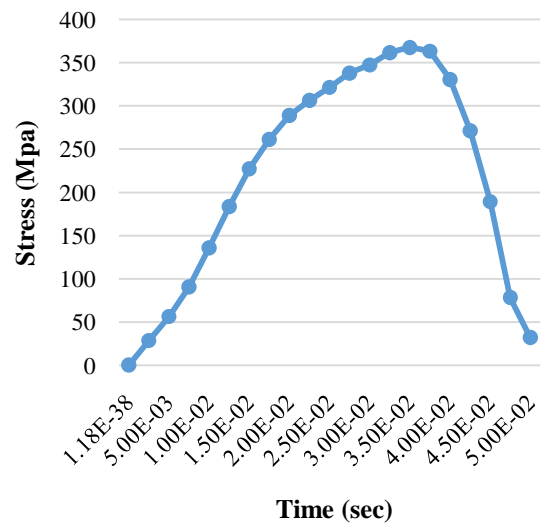
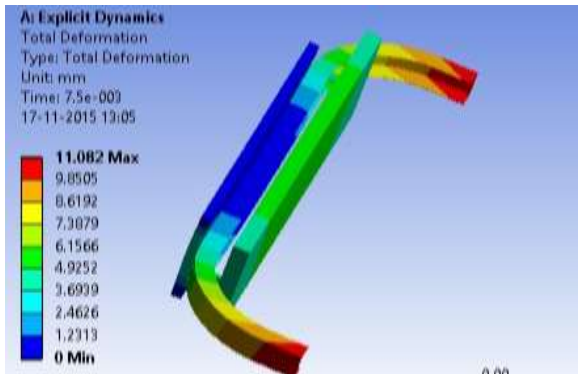

Fig 6 (d). Displacement of the bumper beam in Dynamics

Fig 6 (e) Velocity vs. Time graph of the Steel bumper beam at the impact of 2.5 kmph

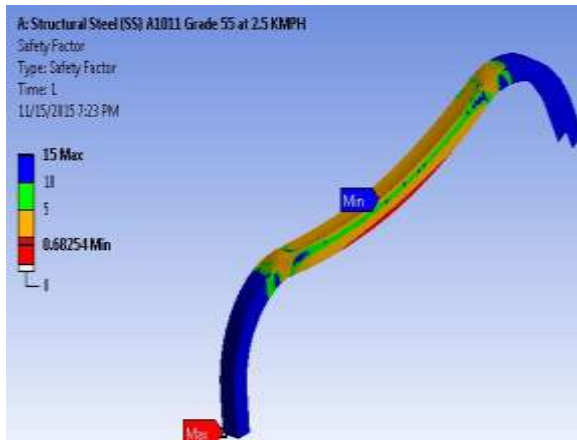

Fig 6 (f) Factor of Safety

Table 3 Comparative results of Statics and Dynamics

TYPE OF SECTION	Bending Stress (N/mm ²)	FEA RESULTS (N/mm ²)		Percentage Difference (%)		Strain Energy (J)
		Statics	Dynamics	Statics	Dynamics	
Simple C- section	379.54	366.28	367.81	3.49	3.26	55.02

From the above analysis we can infer that the existing design could withstand the collision impact at a concentration is observed at the mid portion of the beam not at the fixed supports, it is because of the thickness of the beam which is analyzed above is just 2 mm. The thickness is very less so, the force try's to shear it. Because of which the stress concentration is excess at the mid portion of the beam (flat web).speed of 2.5kmph, but the factor of safety is compromised at some places, the places where factor of safety is compromised as shown in the above results. From the results, the bumper beam starts yielding, maximum deformation is observed at the overhanging portion and the maximum stress.

THICKNESS: - From the above study, when the bumper beam is subjected to an impact at 2.5kmph, the stress induced in the bumper beam is observed such that it had almost reached the yielding stress. Even a slight increase in the impact force, shows a permanent deformation in the bumper beam. To study how thickness of the beam will affect the performance of the bumper, thickness parameter is varied from 2 mm by increasing half an mm for each time up to 5 mm. The results of those are given bellow. From the results we can concur that by a substantial increase in the thickness of bumper the strength of is increased. But, the weight of the components is very important in these days, because it will affect the overall efficiency of the automobile. The material used in the above analysis is Structural Steel (SS) A1011 Grade 55[4], the density of this material is 7850 which increases the effective weight of bumper by increasing the thickness.

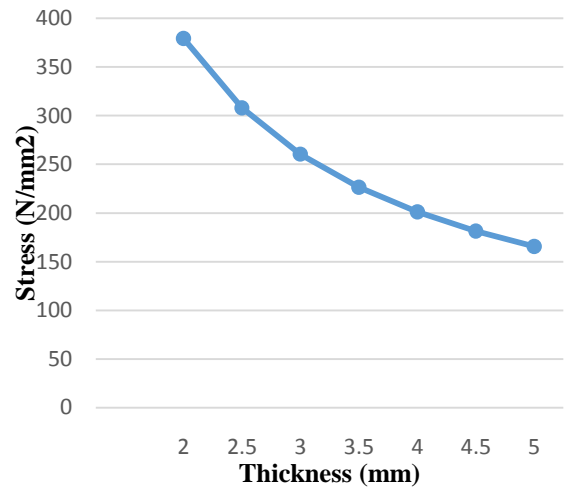

Fig 7(a) Thickness vs. stress of the bumper beam

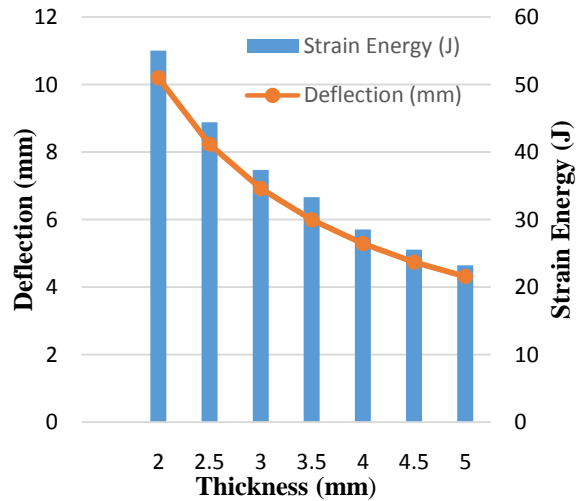

Fig 7(b) Thickness vs. Stress/Strain Energy of the bumper beam

The effective weight of the bumper beam is 16.5 Kg's, for a minimum thickness of 5 mm. Therefore the solution to the above problem is composites which reduce the weight at the same time maintain the strength. The stress values are reducing as the thickness is increasing, but by comparing to first set values and the last set values the stress values are reduced by 18.79% in first set but it reduced by only 8.68% in the last set. That means the stress values will reduces with increasing of thickness at first, but by keeping on increasing won't increase the stress difference between two successive thickness. The same scenario is also observed in the deflection, the deflection of 4.5 mm thickness is 4.74 and to the 5 mm thickness it is 4.31 mm. Which is showing that the deflection will also follows the stress scenario.

SUPPORTS: - The bumper beam can be treated as a simply supported beam, having two fixed supports. In this paper, a study is done in such a way that number of supports will affect the performance of the bumper beam. Increase in the number of supports results in the increase rigidity of the system. In the case of impact condition the impact force is directly transmitted to the chassis, however it won't cause any problem at that particular speed but the components which are placed immediately after the bumper experience a shock which is certainly not desirable. From this, placing the supports in between the original supports results in further problems. So by fixing the overhanging portion of the beam to the car body is a suitable solution.

Table 4 Comparative Results of Varying Supports

Number of fixed supports	Stress (N/mm ²)	Displacement (mm)
2	379.53	10.20
4	294.00	3.69

We observed that my increasing the supports from two to four, the stress value is dropped to 294 N/mm² and the displacement is dropped to 3.96 mm. That means the displacement of the beam is reduced by 63.82%. For composite materials the young's modulus is less compared to steel, so the displacement of the beam will be more. If we can fix the beam at the overhanging portions we can say that the displacement of the beam will reduces. How to fix that ends are out of scope of this project.

Speed: - Bumper beam is designed for protecting the

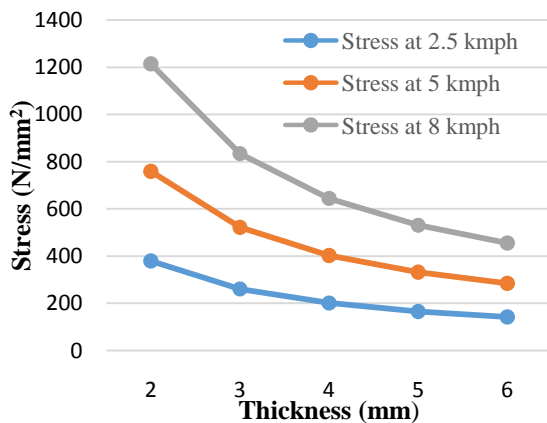

Fig 8(a) Thickness vs. Stress of the bumper beam at various speeds

automobile at low speed impacts. In this paper the speed of 2.5 kmph, 5 kmph and 8 kmph have been studied. Results of this study are shown below to

steel at different speeds. From the above results it can infer that the stress values are reduced significantly while the thickness is increased. Comparative results are shown in fig 8.

According to the European standards the bumper beam should not yield when it is collided at a speed of 8 kmph. Steel at 2 mm thickness is clearly going to break at that condition. To increase the strength of this beam, in this paper the thickness is increased, which also increases the weight. To reach the European standard the beam is to be design for its strength, but the weight of the component is also increasing along with its thickness. Even at 5 mm thickness the stress developed in the beam during collision is 530. 57 Mpa, which is beyond the yield stress, the bumper beam surly fails to serve its purpose. If there is any further increase in the thickness it will cause problems for manufacturing. The weight of 5 mm thickness steel bumper beam is calculated as 16.5 kg. The study is further moved on the materials which gives us the solution for this weight problem.

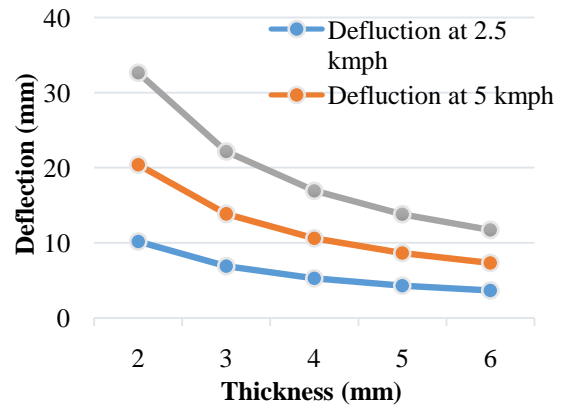

Fig 8(b) Thickness vs. Deformation of the bumper beam at various speeds

Cross- section: - Cross- Section of the bumper beam provides the strength defines the stability and to the beam. Just changing the shape of the cross-section can easily change the strength and stability of the

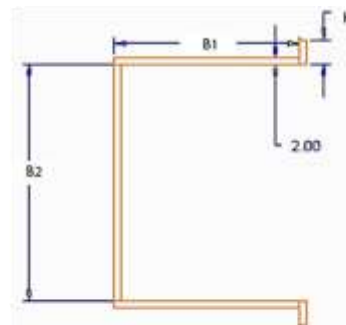

Fig 9 Simple C-section with Hats

bumper the cross-section can easily change the strength and stability of the bumper the cross-sectional area of the beam is fixed as 388 mm², which results in such a way that the weight of the bumper is constant throughout following study. Beam. To study these effect, a few modifications were made to the existing model by keeping total cross-sectional area as constant. In the following study.

a. Simple C- section with Hats:-

The above fig 9 represents the schematic cross-sectional layout of the bumper beam, there were many combinations are applied to it. The dimensions of the all bumper beam and there results are given in below table 5;

Table 5 Bending stress and strain energy of Simple C section with Hat

Type of the bumper beam	B1	B2	H	Maximum bending stress (N/mm ²)		Strain Energy (mJ)
				Analytical	FEA	
S-C-1mm Hat	55	78	3	380.49	410.67	55.21
S-C-2mm Hat	54	78	4	380.03	398.21	55.51
S-C-3mm Hat	53	78	5	384.16	390.89	55.93
S-C-4mm Hat	52	78	6	386.82	384.2	56.47
S-C-5mm Hat	51	78	7	390.03	376.19	57.12
S-C-6mm Hat	50	78	8	393.78	379.31	57.89
S-C-7mm Hat	49	78	9	398.05	389.56	58.79
S-C-8mm Hat	48	78	10	402.85	418.69	59.79

b. Double C- section

The fig. represents the schematic cross-sectional layout of the bumper beam, there were many combinations were applied to it. The dimensions of the all bumper beam is given in below table 6;

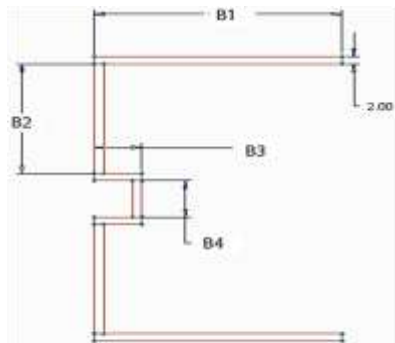

Fig 10 Double C-section

For a bumper beam frontal area is very important parameter, it help to absorb the impact energy, at the same time the other two webs have their own importance. In table case 3 and case 6 have high stress values it is because the support webs for the beam is reduced even though the frontal area is increased. Case 9 have the least stress values in this profile but it is a bit more compared to the simple C, but another

Table 6 Bending stress and strain energy of Double C

Type of the bumper beam	B1	B2	B3	B4	Maximum bending stress (N/mm ²)		Strain Energy (J)
					Analytical	FEM	
Case 1	52	30	10	10	447.36	476.0	75.56
Case 2	44.5	30	15	15	566.41	532.1	116.92
Case 3	37	30	20	20	791.95	797.1	178.88
Case 4	47	35	10	10	477.94	515.6	96.58
Case 5	39.5	35	15	15	645.29	625.6	155.90
Case 6	32	35	20	20	870.97	828.3	231.90
Case 7	42	40	10	10	522.70	496	128.22
Case 8	58	24	10	10	423.98	405.9	58.73
Case 9	58	26	8	10	409	428.6	57.60

Parameter is decreased in double-C that is strain energy. The strain energy is decreased up to 8% then the simple C. which is very much desirable parameter in bumper beam design.

From the cross sectional study, the stress values are changing with respective to the cross sections, the Hats are provided for giving a support along the beam. Since the beam will deflect when it is collided to the impactor, the surface area of beam is increased at the hated portion. The hated portion of the beam will generate a new support with car body when it pass the gap in between the beam and car body but to deflection or deformation. But all these studies are done in constant cross-section criteria, which means the weight of the bumper beam is constant throughout the cross section study.

Material:-

Material is the one of the important parameter that effect the bumper beam performance, the material should have the good impact strength and at the same time it should have low density. The effect of bumper material on the beam and its impact behavior are studied below:

Table 7 Material properties

Type of Material	Young's Modulus (GPa)	Poisons Ratio (μ)	Density (ρ Kg/m ³)
Steel[6]	207	0.3	7860
Aluminum[6]	68.9	0.33	2720
Magnesium AZ31B[6]	450	0.35	1740
Carbon Fiber Epoxy[9]	85	0.15	1600
PEI[10]	31	0.3	1480
Glass Epoxy[8]	78	0.28	1900
GMT[6]	12	0.41	1280
SMT[6]	20	0.33	1830
S2 Glass Epoxy[10]	86.9	0.23	2460

By studying the effect of Young's modulus on the bumper, three materials are considered. The impactor collided with these bumper at a speed of 2.5kmph velocity. The above table gives the compared results of longitudinal deflection and the bending stiffness. From the results the Magnesium have the high stiffness prior to steel. Steel stiffness is higher than that of aluminum. Among the materials listed above, Magnesium have lowest density (1740 kg/m³), but it is very costly. When we came's to aluminum bumper, due to its low bending stiffness the area of impact of the beam is large. Which means a large amount of area is involved in the collision. Therefore plastic deformation is large and dissipation of energy is minimal since COR is bigger than that of other materials. It is also observed, from the energy summary of aluminum, steel and magnesium that are

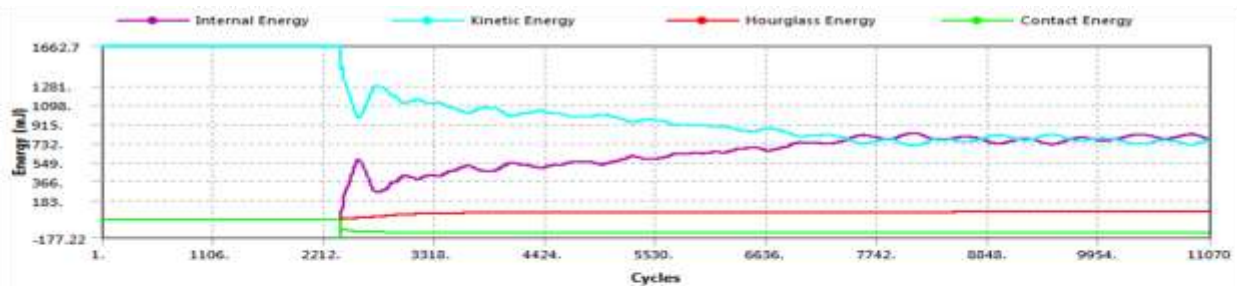

Fig 11(a). Impact Energy Summary of Steel under Self-Weight

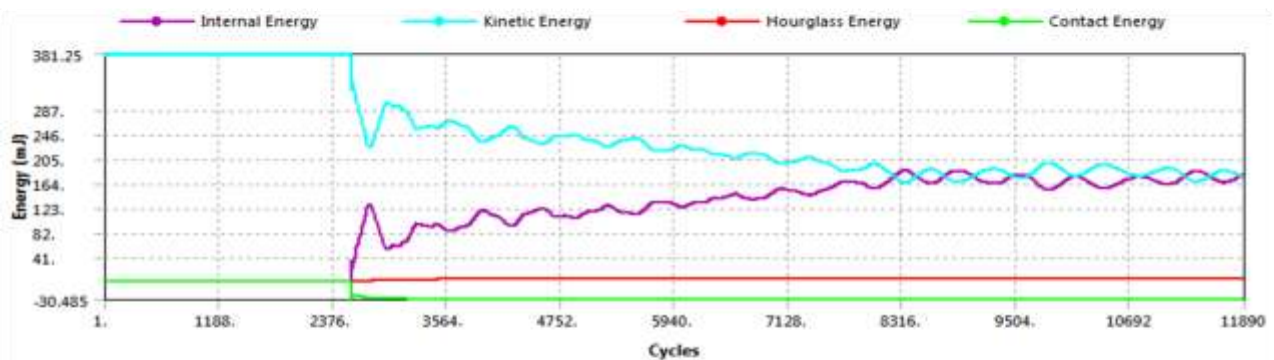

Fig 11 (c). Impact Energy Summary of Magnesium under Self-Weight

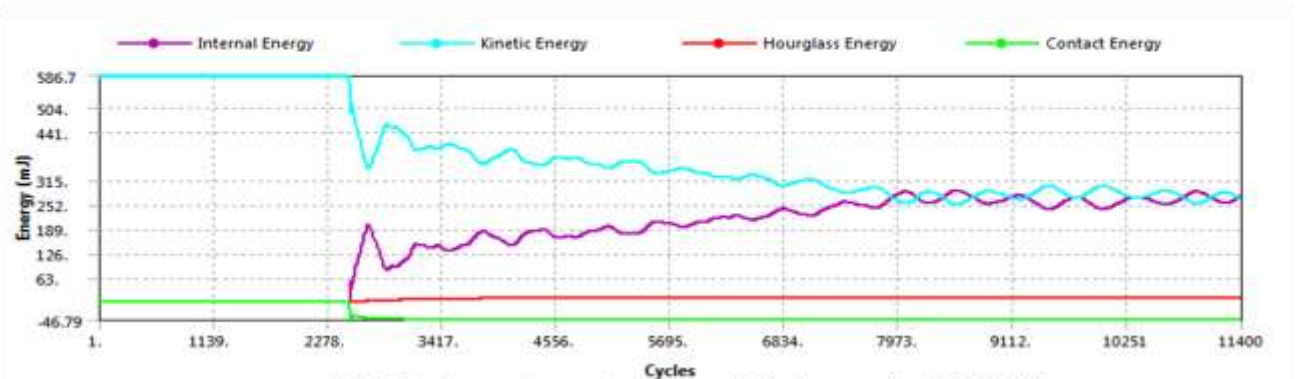

Fig 11(b). Impact Energy Summary of Aluminum under Self-Weight

plotted below. From the graph the impact force generated in aluminum bumper is less. The impact force mainly depended on the mass and the velocity of the car. The weight of the bumper can be minimized by using low density materials, which should have enough impact strength. Another observation is also made from above plot; the kinetic energy of the bumper beam is mostly converted to deformation the beam and try to be in motion. From the cross-sectional study, the simple C- section shows good results among all other cross-sections in this work. To investigate the effect of bumper beam material and thickness on this cross-section, two parameters were evaluated; bending stiffness and the deflection. The results of various material and thickness of 2 mm and 6 mm are given above.

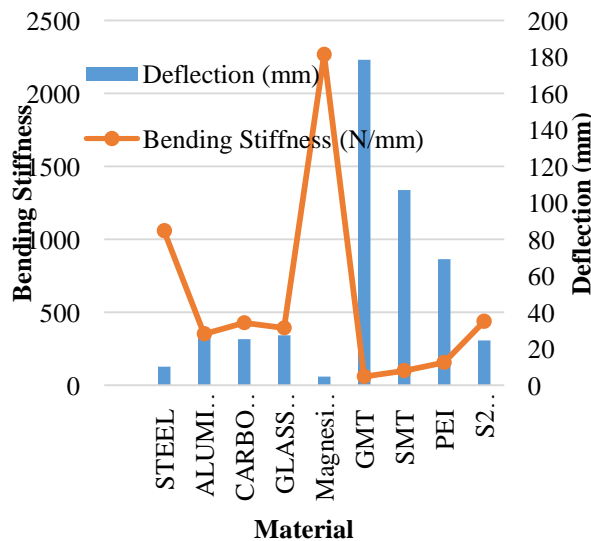

Fig 12 (a) Materials vs. Bending Stiffness/Deformation of 2 mm bumper beam

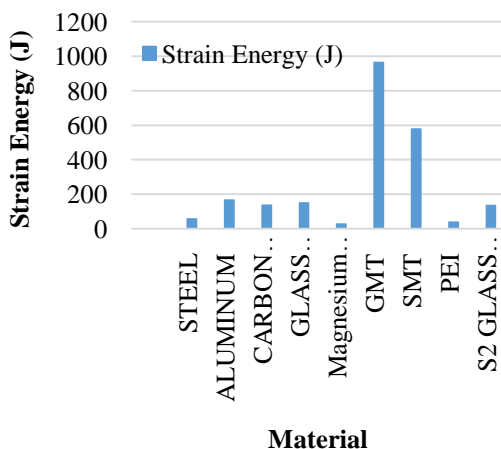

Fig 12 (b) Materials vs. Strain Energy of 2 mm bumper beam

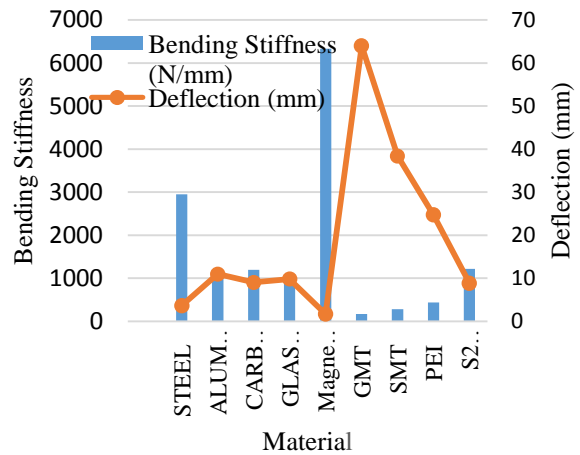

Fig 13 (a) Materials vs. Bending Stiffness/Deformation of 6 mm bumper beam

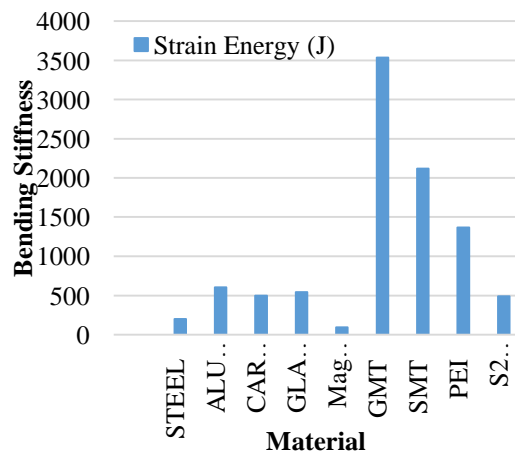

Fig 13 (b) Materials vs. Bending Stiffness/Deformation of 2 mm bumper beam

The stress developed in the bumper beam is 455.01 Mpa, the yield strength of the steel material is 380 Mpa, which is less than that of the induced stress. But the yield strength of the S2 glass epoxy is 480 Mpa, which can withstand a speed of 8.0 kmph collision.

Effect on bumper beam due to the passenger weight:-

The presence of passengers will definitely effect the stress and deformation in the bumper beam. For analyzing it a mass of 350 kg's where considered additionally and added to the weight of car. Steel is analyzed in this process and the results are tabulated below.

Table 9 Effect on bumper beam due to the passenger weight

PASSENGERS WEIGHT	TYPE OF SECTION	Bending Stress (N/mm ²)	DEFLECTION (mm)
Without Passengers	Simple C- section	379.53	10.19
With Passengers	Simple C- section	468.76	12.59

From the above analysis the stress values are raised by 18.87% and deformation is increased 19.06%. So to meet the standards of the European bumper beam specifications, passenger weight parameter is also to be considered for better performance.

Discussion: - Bumper beam in an automobile is a key structure for absorbing the accidental impact energy generated during the collision, which is characterized by using FEM modeling in this paper, in accordance with the low velocity impact conditions of European standards. [8] Few commercial materials were selected and based on the design parameters such as thickness, supports, cross-section, materials and impact conditions were investigated and evaluated by using analytical method. Conventional materials showed inappropriate characteristics like the structural failure and weight of the bumper beam. [10] According to the standards of automobiles, the bumper beam of passenger car have to withstand the frontal and rear low-velocity impact without any serious damage. The severity of the damage due to the impact load caused by the collision in the bumper beam should not deform the body more than that of the plastic region.

In this study, the thickness parameters of the beam is the main parameter that determines the strength of the beam. 5 mm thickness beam has the strength to withstand at 2.5 kmph but at 8.0 kmph the failure is beyond the plastic region. Conventional Materials like steel and aluminum will not going to withstand the collision at 8.0 kmph. The stress generated in the steel bumper beam of 6 mm thickness is 455.01 Mpa which is way beyond the yield stress, S2 glass epoxy of 6 mm thickness is used to withstand 8.0 kmph impact. The cross section of this beam is Simple C- section and the yield strength of the S2 glass epoxy is 480 Mpa, the stress induced in the bumper beam of 6 mm thickness is

455.01 Mpa which is less than the yield strength. From these S2 glass epoxy will withstand the collision at 8.0 kmph.

Conclusion: - In the present work of designing an automobile bumper there are two limitations.

1. The deflection caused in the bumper during collision must not exceed the maximum value of 30mm.
2. No plastic deformation should occur in the bumper beam so as to protect the automobile assembly such as the engine, cooling system and the fuel unit from the damage. The maximum stress that is observed in the beam should be below the yield stress. For an effective bumper beam, the design must necessarily satisfy the above conditions and the material used for the beam should also provide a reduction in weight

From this study the following results were obtained.

1. By using the conventional materials which have low Young's modulus results in low rigidity and by using of high-strength materials have shown good impact behavior. But the high strength conventional materials will also have high density that in turn increases the weight. The stress induced in the beam should be less than that of the yield strength. So, the materials having high yield strength are best suited for the manufacturing of bumper beam.
2. By increasing the bumper beam thickness will increase the rigidity and the impact resistance generated in the collision. Consequently, this results in the reduction of the stress and deflection in the bumper beam. On other hand by increasing the thickness will also increases the weight, so materials having low density are best suited.
3. The presence of passengers in the vehicle could have negative impact on the bumper beam, which will increase the deflection and stresses in the beam. From this analysis the bumper beam which has good performance in the case of with passengers will surely have better performance in the case of "without passengers"

The S2 Glass epoxy material with simple C-section of 6 mm thickness have shown better stress and deflection results incorporative to steel.

While comparing the strain energies, double C-section has better results than the Simple C-section.

In order to achieve higher stability, cost effective and manufacturability of the product, the S2 glass epoxy is proposed that could replace the steel, based on strength and weight criteria.

Imide And S2 Glass Epoxy Material By Solid works Software, IJRMET, Vol-4, Issue 1, NOV 2013, ISSN:2249-5770.

References:-

- [1]. Davoodi, M.M.. "Development process of new bumper beam for passenger car: A review", *Materials and Design*, 201209.
- [2]. M.M. Davoodi, S.M. Sapuan, D. Ahmad, "*Concept Selection of Car Bumper Beam with Developed Hybrid Bio-Composite Material*", *Materials and Design* (2011), 32, 4857–4865.
- [3]. S. Prabhakaran, K. Chinnarasu, M. Senthil Kumar "*Design and Fabrication of Composite Bumper for Light Passenger Vehicles*" (*Ijmer*) Vol.2, Issue.4, July-Aug. 2012 Pp-2552-2556.
- [4]. United Nations Agreement, Uniform Provisions Concerning the Approval of Vehicles With Regards To Their Front and Rear Protective Devices (Bumpers, Etc.), E.C.E., 1994.
- [5]. Yasuhiro Matsui, "*Effects of Vehicle Bumper Height and Impact Velocity on Type of Lower Extremity Injury in Vehicle–Pedestrian Accidents*", *Accident Analysis and Prevention* 37 (2005) 633–640
- [6]. Javad Marzbanrad, Masoud Alijanpour, Mahdi Saeidkiasat, "*Design and Analysis of an Automotive Bumper Beam In Low-Speed Frontal Crashes*" *Thin-Walled Structures* (2009), 47, 902–911
- [7]. Hosseinzadeh R, Shokrieh Mahmoud M, Lessard L.B, "*Parametric Study of Automotive Composite Bumper Beams Subjected to Low-Velocity Impacts*" *J Composite structures* 2005; 68:419–27.
- [8]. S.M. Sapuana, M.A. Malequea, M. Hameedullaha "*A Note on the Conceptual Design of Polymeric Composite Automotive Bumper System*" *Journal of Materials Processing Technology*, 159 (2005) 145–151.
- [9]. Alen John, Nidhi M.B, "*Modeling and Analysis of an Automobile Bumper Beam Used for a Low Passenger Vehicle*", *IJETT*, Vol-15, Sep-2014.
- [10]. V.Mohan Srikanth, K.Venkateswara Rao, M.Sri Rama Murthy, "*Impact Analysis of Car Bumper For Various Speed Using Carbon Fiber Reinforced Poly Ether*