

Columns Retrotting with Glass Fiber and Carbon Fiber Composite Laminates

Owais reshi ^{#1}, Md Zakir ^{*2}

[#] M-Tech Structure student at Lords Institute of Engineering and Technology
Jawaharlal Nehru Technological University Hyderabad
Kukatpally, Hyderabad-5000085, Telangana, India

Abstract— *the important application of this composite retrofitting technology is the use of fiber reinforced epoxy composite laminates (FRECL) or sheets to provide external confinement to RC columns when the capacity of existing structure is inadequate. Use of externally bonded FRECL composite for strengthening can be a cost effective alternative for upgrading the performance of existing RC columns. More research work is been carried out analyzing on the flexural behaviour of RC beams, efficiency of HFRECL confinement related to the radius of the cross-section edges, size and shape of the concrete column cross section. The aim of this paper is to study the structural behavior of reinforced concrete columns strengthened with carbon fiber laminates and glass fiber laminates and compare their results with unretrofitted columns. The main task of this eperiment were conducted to investigate the effects of additional strengthening of reinforced columns. Composite materials have been subject of permanent interest of various specialists during the last decades Composites offer many advantages when compared to metal alloys, especially where high strength and stiffness to weigh ratio is concerned, excellent fatigue properties and corrosion resistance.*

I. INTRODUCTION

Composite plastics refer to those types of plastics that result from bonding two or more homogeneous materials with different material properties to derive a final product with certain desired material and mechanical properties. Fiber-reinforced plastics are a category of composite plastics that specifically use fiber materials to mechanically enhance the strength and elasticity of plastics. The original plastic material without fiber reinforcement is known as the matrix. The matrix is a tough but relatively weak plastic that is reinforced by stronger stiffer reinforcing filaments or fibers. The extent that strength and elasticity are enhanced in a fiber-reinforced plastic depends on the mechanical properties of both the fiber and matrix, their volume relative to one another, and the fiber length and orientation within the matrix. Reinforcement of the matrix occurs by definition when the HFRECL material exhibits increased strength or elasticity relative to the strength and elasticity of the matrix alone.

Use of externally bonded HFRECL composite for strengthening can be a cost effective alternative for upgrading the performance of existing RC columns. More research work is been carried out analyzing on the flexural behaviour of RC beams, efficiency of HFRECL confinement related to the radius of the cross-section edges, size and shape of the concrete column cross section. Thus six reinforced concrete column specimens were casted and wrapped and unwrapped samples were tested in order to get the experimental results. Different country has formulated different types of design steps to find out the compressive strength. The design of the fiber composite system was done as per the guide lines from ISIS - Canada fiber wrap Manual no.4. The analytical results were derived as per guidelines of ISIS - Canada and thus these results were compared with the experimental results. Thus verifying the design steps mentioned in the fiber wrap manual.

Over the last 10 years, considerable efforts to improve the behaviour of cementitious materials by incorporating fibers have led to the emergence of Ultra-High Performance Fiber Reinforced Concretes (HFRECL). These novel building materials provide the structural engineer with a unique combination of

Extremely low permeability which prevents the ingress of detrimental sub-stances such as water and chlorides

Very high strength, i.e., compressive strength higher than 150 MPa, tensile strength higher than 10 MPa and with considerable tensile strain hardening and softening behavior.

Consequently, HFRECL have improved resistance against severe environmental influences and high mechanical loading thus providing a potential to significantly improve structural resistance and durability to concrete structures.

This keynote presents an original concept for the rehabilitation and strengthening of concrete structures. The concept is described and some scientific background regarding the structural behaviour of RC elements strengthened with HFRECL is given. Finally, this novel technology is validated by means of applications.

II. EFFECTS OF COMPOSITE LAMINATES ON STRUCTURES

A lamina or ply is formed by a combination of a large number of fibers in a thin layer of matrix.

Fibers in the lamina may be continuous or discontinuous, arranged in a specific direction or in another in a particular direction. It is natural that discrete fiber composite will have lower strength and modulus than continuous fiber composite. However, with the random orientation of the fiber, it is possible to obtain nearly equal mechanical and physical properties in all direction in the plane of the lamina.

It is a flat (or sometimes curved) arrangement of unidirectional (or woven) fibers suspended in a matrix material. A lamina is generally assumed to be orthotropic, and its thickness depends on the material from which it is made.

The laminate's response depends on the properties of each lamina, as well as the order in which the lamina are stacked.

So, to construct a product (laminate) we have to use a several lamina with determined orientation to achieve properties that we want. Usually, lamina is not used without stacking it to create a laminate. This lamina is being hold together thanks to the resin that we choose depending on service condition of the product.

A laminate is a bonded stack of lamina with various orientations of principal material directions in lamina as in figure. Note that the fiber orientation of the layers in the figure is not symmetric about the middle surface of the laminate. The layers of a laminate are usually bonded together by the same matrix material that is used in the individual lamina. That is, some of the matrix material in a lamina coats the surfaces of a lamina and is used to bond the lamina to its adjacent lamina without the addition of more matrix material. Laminates can be composed of plates of different materials or, in the present context, layers of fiber-reinforced lamina.

A major purpose of lamination is to tailor the directional dependence of strength and stiffness of a composite material to match the loading environment of the structure element. Laminates are uniquely suited to this objective because the principal material directions of each layer can be oriented according to need. For example, six layers of a ten-layer laminate could be oriented in one direction, the resulting laminate then has a strength and extensional stiffness's in the two directions is approximately 6:4, but the ratio of bending stiffness's is unclear because the order of lamination is not specified in the example. Moreover, if the laminate is not arranged symmetrically about the middle surface of the laminate, the result is stiffness's that represent coupling between bending and extension.

III. GLOBAL APPLICATIONS

Commercial and Industrial applications of FRHL are diverse and Varied. Some of these applications are ships and submarines, aircrafts and space crafts, trucks and rail vehicles, automobiles and robots and civil Engineering structures. The main application areas can be broadly classified as:

A. Marine Field

Glass reinforced polymers are extensively used in the construction of boats including yatch, lifeboats, canoes, speedboats, fishing boats, etc.

Glass reinforced Plastics is used because of its competitive low cost, trouble free performance, low maintenance cost and Aesthetics.

B. Aircraft and Space

The most important application of areas of FRHL is in the field of Civil and commercial Aircrafts. FRHL with Epoxy as resin is used for manufacture of Helicopter blades. Graphite Fibers are well suited for space applications because of their high specific strength and low coefficient of thermal expansion.

C. Automotive Field

Use of FRHL in the automotive industry is much less than the aircraft industry. The techniques used in automotive industries are compression moulding, resin transfer moulding, etc are used. FRHL have been used in many parts of the car. The advantage in the racing cars using FRHL is reduction of engine weight.

D. Sporting Goods

Many Sporting goods are made of FRHL. Nowadays, one of the major advantages is the reduction of weight, enabling of damping vibrations, without any decrease in stiffness. FRHL in sports application are fishing rods, bicycle frames, Archery bows, Rackets, Helmets, Golf bats, Surf Boards, etc.

IV: SUITABILITY OF HFRECL FOR USES IN STRUCTURAL ENGINEERING.

The strength properties of HFRECLs collectively make up one of the primary reasons for which civil engineers select them in the design of structure. A material's strength is governed by its ability to sustain a load without excessive deformation or failure. When an HFRECL specimen is tested in axial tension, the applied force per unit cross-sectional area (stress) is proportional to the ratio of change in a specimen's length to its original length (strain).

When the applied load is removed, HFRECL returns to its original shape or length. In other words, HFRECL responds linear-elastically to axial stress. The response of HFRECL to axial compression is reliant on the relative proportion in volume of fibers,

the properties of the fiber and resin, and the interface bond strength.

HFRECL composite compression failure occurs when the fibers exhibit extreme (often sudden and dramatic) lateral or sides-way deflection called fiber buckling. HFRECL's response to transverse tensile stress is very much dependent on the properties of the fiber and matrix, the interaction between the fiber and matrix, and the strength of the fiber-matrix interface.

V.WRAPPING OF COLUMNS

The concrete surface needed to be cleaned with wire brush to remove all the loose dust particles. Primer coats were applied over the concrete surface. Epoxy resin mix was made from the two different parts i.e. base and hardener. They were taken in equal proportion and mixed together. Epoxy resin mix was applied over the surface with hand brush. After application of the epoxy resin mix a pre-cut HFRECL sheet were wrapped around the columns with the help of tamping brush and roller. The fibers were impregnated with epoxy resin mix in order to achieve complete confinement. The air pockets were removed with the help of roller.

All columns were wrapped following standard procedure indicated below:

Surface Preparation: The surface of the structure was cleaned and prepared for installation through the use of sand blasting.

A.Primer Application: A coat of Primer is applied to the concrete surface. The primer prepares the surface of the concrete for the application of the CHFRECL sheets.

B.Putty Application: A very thin coat of Putty is smoothed over the surface to fill in any small voids, cracks or uneven surfaces.

C.First Hand of saturant Application: A layer of saturant is applied next. This precedes the installation of the first layer of CHFRECL.

D.HFRECL Sheets Application: The first layer of HFRECL sheets is then applied. The sheets are rolled into the saturant to insure good adhesion.

E.Second Hand of saturant Application: A second application is necessary to ensure good penetration of the saturant around the fibers.

VI.REFERENCES

- Ramana et al., experimentally investigated the flexural strengthening of reinforced concrete beams by the external bonding of high-strength, light-weight carbon fibre reinforced polymer

composite (CFRPC) laminates to the tension face of the beam. Four sets of beams, three with different amounts of CFRPC reinforcement by changing the width of CFRPC laminate, and one without CFRPC were tested in four-point bending over a span of 900 mm. The tests were carried out under displacement control. One beam in a set was extensively instrumented to monitor strains and deflections over the entire range of loading till the failure of the beam.

- Sherif H. Al-Tersawy et al., examined the performance of reinforced concrete (RC) beams strengthened in shear. Experimental investigation was carried out on nine RC beams of three different sets, as-built beams (unstrengthened), beams strengthened with vertical carbon fiber-reinforced polymer (CFRP) wraps, and beams strengthened with inclined CFRP wraps. The main parameters investigated were concrete strength, CFRP thickness and wraps orientations (90o,45o).
- Akhrawat Lenwari et al., investigated the effects of the two types of fiber sheets, namely, carbon and glass fiber sheets, on the flexural behaviors of reinforced concrete (RC) beams when they are bonded to the tension zones of the beams. A total of eight full-scale beams were tested in the experiments. The flexural strength and stiffness of RC beams were found to increase significantly after the installation of fiber sheets. Finally the characteristics of debonding problem which limits the effective use of fiber materials are highlighted.
- Zhichao Zhang et al., examined the shear behavior of RC beams with externally bonded CFRP shear reinforcement. In this study, 11 RC beams without steel shear reinforcement were casted. After the beams were kept in the curing room for 28 days, carbon-fiber strips and fabrics were applied on both sides of the beams at various orientations with respect to the axis of the beam. Results of the test demonstrate the feasibility of using an externally applied, epoxy-bonded CFRP system to restore or increase the shear capacity of RC beams. The CFRP system can significantly increase the serviceability, ductility, and ultimate shear strength of a concrete beam; thus, restoring beam shear strength by using CFRP is a highly effective technique.

- Ayman S. Mosallam et al., presented the results of an experimental investigation on shear strength enhancement of reinforced concrete beams externally reinforced with fiber-reinforced polymer (FRP) composites. A total of nine full-scale beam specimens of three different classes, as-built (unstrengthened), repaired and retrofitted were tested in the experimental evaluation program. Three composite systems namely carbon/epoxy wet layup, Eglass/epoxy wet layup and carbon/epoxy procured strips were used for retrofit and repair evaluation. Experimental results indicated that the composite systems provided substantial increase in ultimate strength of repaired and strengthened beams as compared to the pre-cracked and as-built beam specimens.

VI. TESTING OF CONCRETE COLUMNS CONFINED WITH FRECL

A. Experimental Investigation

Four rectangular columns were tested under pure axial load. Two of them were control specimen without FRECL used as a benchmark. One rectangular column was wrapped using the ± 45 degree FRECL (Carbon FRECL) laminates (DB450-C) and one using a unidirectional FRECL laminate (CF-130). Three circular columns were tested using the ± 45 -degree laminate, and three unidirectional HFRECL laminates, CF-130, L200-C, and L300-C. Column is made with M20 grade concrete and Fe-415 grade steel is used for longitudinal reinforcements and Fe-250 grade steel is used for stirrups and lateral ties. The columns are longitudinally reinforced with 4 Nos. of 13mm diameter bars and laterally tied with 6mm diameter bars placed at 100 mm c/c. The details of sample are shown in fig. 1.

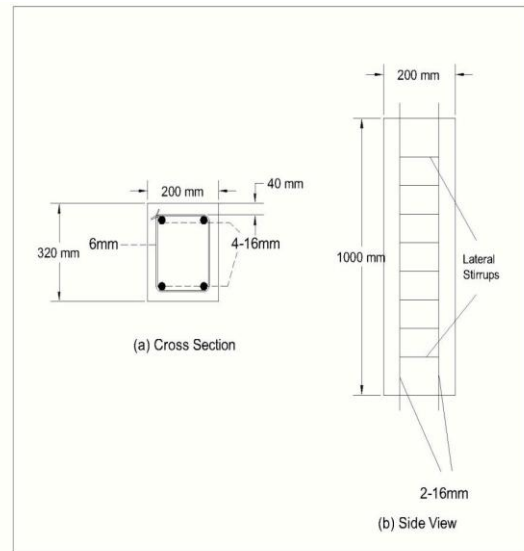

Figure 1: specimen details

B. Test set-up and failure in columns

Strain gages were applied to longitudinal and lateral steel to record axial and circumferential strain. Strain gages were also placed on the external FRECL reinforcement. A sketch showing the position of the gages for the columns wrapped with the ± 45 -degree carbon FRECL is given. Three LVDT's (Linear Variable Differential Transducers) were also used to record lateral displacement of the column.

The typical collapse mechanism of the specimens was usually marked by sudden failure. Approaching ultimate strength, noise associated with localized debonding, fiber failure, and crushing of concrete was detected. Because of the geometrical configuration adopted, the location of the failure region occurred in the middle height of the specimen. A comparison between unwrapped and wrapped with DB450-C rectangular and circular columns is given in chart 1. Rectangular specimens show a smaller axial load capacity and ductility due to the stress concentration at the corners that decreases the efficiency of the cross section.

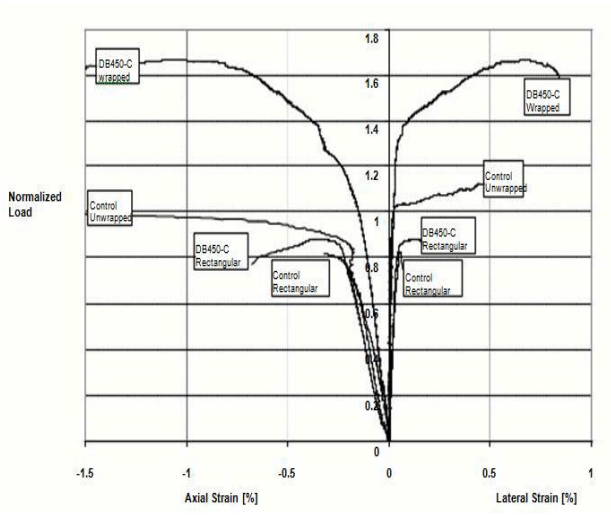

Chart 1: Comparison between wrapped and unwrapped columns

VII. AXIAL COMPRESSION STRENGTH

The experimental results clearly demonstrate that FRECL jacketing enhances the structural performance of RC columns under axial loading as shown in charts 2 and 3 respectively. The reinforced concrete column specimens without retrofitting had a brittle failure and the ultimate load recorded was close to expected ultimate load. Failure was initiated by spalling of the concrete cover followed by local buckling of the reinforcing steel and immediately crushing of concrete core. Retrofitting of reinforced concrete columns with glass and carbon laminates of 1mm and 1.6mm thickness enhances the compressive strength of these columns more than double and triple the strength of the original column respectively.

Chart 2: Axial Strength comparison of specimens' 5C-3 and 5C-4

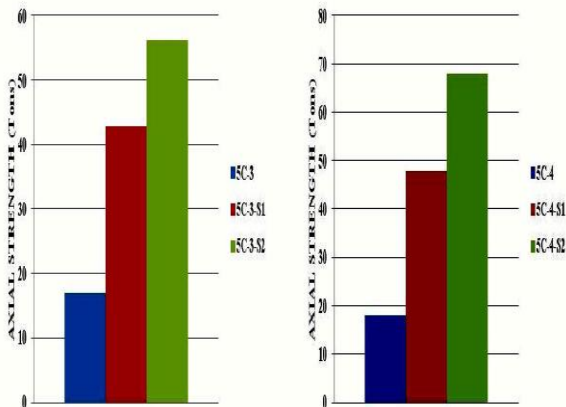
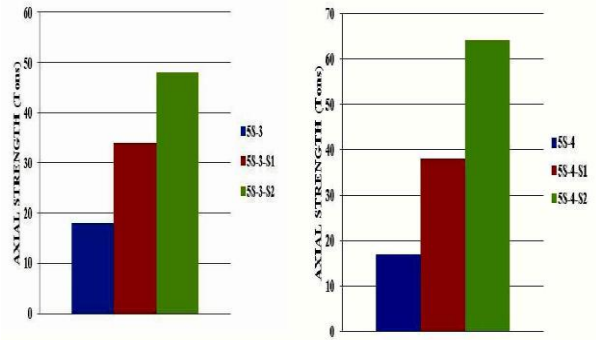

Chart 3: Axial Strength comparison of specimens' 5S-3 and 5S-4



VIII. STRESS STRAIN BEHAVIOUR

Stress-strain behaviour of various RCC column specimens, with and without composite Laminates, under axial compression are graphically shown in chart 4 and 5 respectively.

Chart 4: Stress-strain curves for specimen 5C-3 and specimen 5C-4 respectively

Chart 5: Stress-strain curves for specimen 5S-3 and specimen 5S-4 respectively.

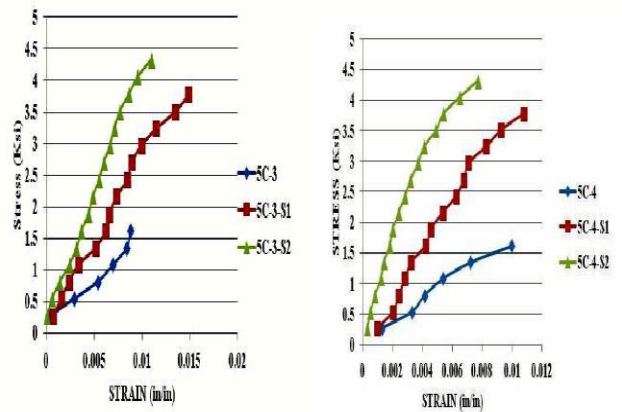

4 respectively.

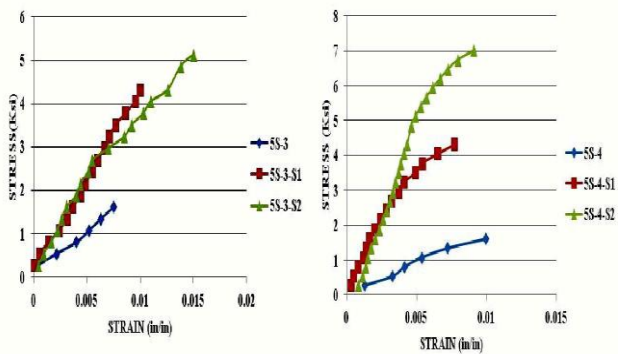

IX. CONCLUSIONS

Based on the experimental investigations carried out the following conclusions are made:-

- There is a significant increase in the axial strength and peak load strain of retrofitted column specimen
 - It is observed that at low displacement levels, the energy absorbed by both GFRP and CFRP wrapped specimens were less than that by the specimen without FRP wrapping
 - At higher levels of lateral displacement, the energy absorbed by the column wrapped with both GFRP and CFRP was much higher than the column without FRP wrapping.
 - The retrofit measures of this study resulted in only modest improvements over the performance of the as-built specimens. This is due to the relatively good performance of as-built specimens that limited the available potential for improvement.
 - The specimens jacketed with CFRP have an average of 98.3% increase in the strength capacity compared to the specimen without CFRP wrapping.
 - There is an average 2.7% increase in ductility for the specimens wrapped with CFRP when compared to the specimen without CFRP wrapping.
- 9: de Lorenzis, L.– Tefers, R. (2000) Applicability of FRP Confinement to Strengthen Concrete Columns. Nordic Concrete Research, Publication No. The Nordic Concrete Federation
- 10: Miyauchi, K. - et al. (1999) Strengthening Effects of Concrete 31. Column with Carbon Fiber Sheet. Transactions of the Japan 13: Concrete Institute vol. 21, 1999, pp. 143 – 150.

X.REFERENCES

- 1: Neubauer, U. and Rostasy, F. S. Design aspects of concrete structures strengthened with externally bonded CFRP plates, In: Proceedings of the 7th International Conference on Structural Faults and Repairs. Edinburgh, Scotland, ECS Publications. 1997; 2: 109–118.
- 2: Roberts, T.M. (1989). Approximate analysis of shear and normal stress concentration in the adhesive layer of plated RC beams. *The Structural Engineer*, 1989; 67 (12/20): 229-
- 3: Obaidat, Y., Hayden, S., and Dahlblom, O. Bond action between FRP and concrete - A new model. Submitted, 2011.
- 4: Bathe, K.J. Finite element procedures. Prentice Hall 2006.
- 5: Obaidat, Y., Hayden, S., and Dahlblom, O. Plate end debonding: A modified approach to stress in FRP–concrete bond. Submitted, 2011.
- 6: Karbhari, M. – Douglas, A.E. (1995) Effects of Short-Term Composite Jacketed Concrete. American Society for Testing and Materials, 1995
- 7: Fiber-Reinforced Polymer Bars. *ACI Structural Journal*, January – February 2002, pp. 116-125.
- 8: Columns Using FRP Sheets-Applications. The University of Manitoba, Composite Materials in Civil Engineering, 2002 de Paula, R.F. - da Silva, M.G. (2002) Sharp Edge Effects Conference on Composites in Infrastructure, ICCI 2002