

# Design and Fabrication of an Industrial Tank Mounting and Lowering (M-L) Machine

C. C. Eze\*<sup>1</sup>, D. C. Nnadi<sup>2</sup>, C.S. Agu<sup>3</sup> and J. C. Aririguzo<sup>4</sup>

Department of Mechanical Engineering, Michael Okpara University of Agriculture, Umudike, Abia state, Nigeria.

## Abstract

*A portable plastic tank lifting and lowering machine is designed and fabricated. This machine has a mounting gadget that makes it possible to be hoisted at a height, and the retractable ram and arm to move and swindle around to locate the tank to be re-located for washing. In a lifting and lowering test-run, the 150v-400 kg capacity electric winch bearing machine lifted and later lowered to the ground a 300 kg mass tank for washing. The machine components with the exception of the winch are all locally sourced. The winch may be adapted and replaced by a 200v electric winch from Japan for heavier load bearing. The total machine cost is N43, 800, about \$87 only.*

**Key words:** Electric winch, Lifting-and-Lowering, Retractable rope, Plastic tank, Washing, Hook.

## 1. INTRODUCTION

Without doubts, industries indeed need industrial tanks. Industrial tanks serve different and specific purposes, depending on the type of industries. These tanks hold water, drinks, chemicals, and sometimes serve as storage facilities. Some are for clean water storage for diluent and blending purposes. Others are for storage of drinks to be bottled, and so on. In whatever capacity they serve, they need to be clean and devoid of unwanted dusts and particles [1]. They may be washed and dusted from time to time and at intervals to avoid contaminations.

Thus the serious challenges associated with these tanks and their users is in the very vital area of keeping the containers clean. They are usually large containers that are not portable enough to toss about during washing

and cleaning up. Most at times, they are mounted upstairs, at heights beyond the reach of hands. In these cases, it becomes impossible to wash and inspect them properly, and to achieve some hygienic standards [2]. They must therefore be brought down for thorough washing after which they must equally be re-mounted again. Tank mounting and lowering (M-L) is an onerous task, and this container being a fragile object somehow, extreme care must be taken to avoid damages in the operation, more so nowadays when the cost of a unit tank is worth some months of a couple of the labourers' wages. It becomes worse if the tank smashes with some commodities in it. Adequate tank mounting and lowering operation is therefore very necessary to forestall this unfortunate but avoidable outcome that could cause the collapse of a whole establishment. An industrial tank mounting and lowering machine (M-L) is therefore a necessity.

## II MATERIALS AND METHODS

Figure 1 is the design needed here. It is the portable type that could be mounted up at any height or orientation and made to operate at some desired ranges. It may be taken up to this height, mounted on any strong frame and let loose the long rope. The retractable rack may swindle about, about the joint to locate any direction with the steel rope also being able to retract or protrude. The main frame may also increase or decrease in height by manual winding or by the help of an electric motor. Thus, the winch can locate any tank to re-locate, drop or deliver it as desired.

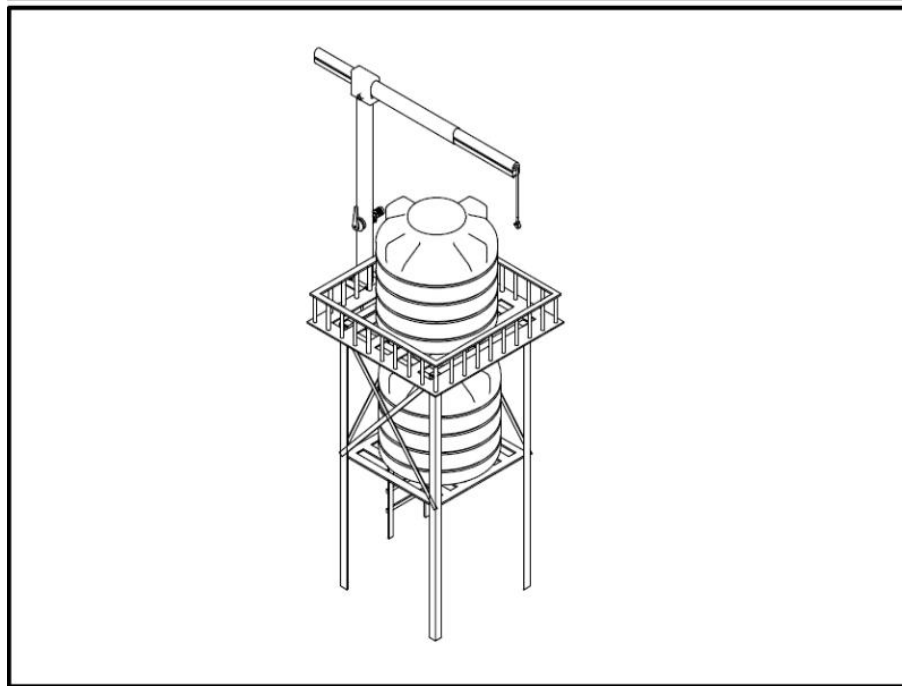

Fig. 1: The Industrial mounting and lowering (M-L) machine.

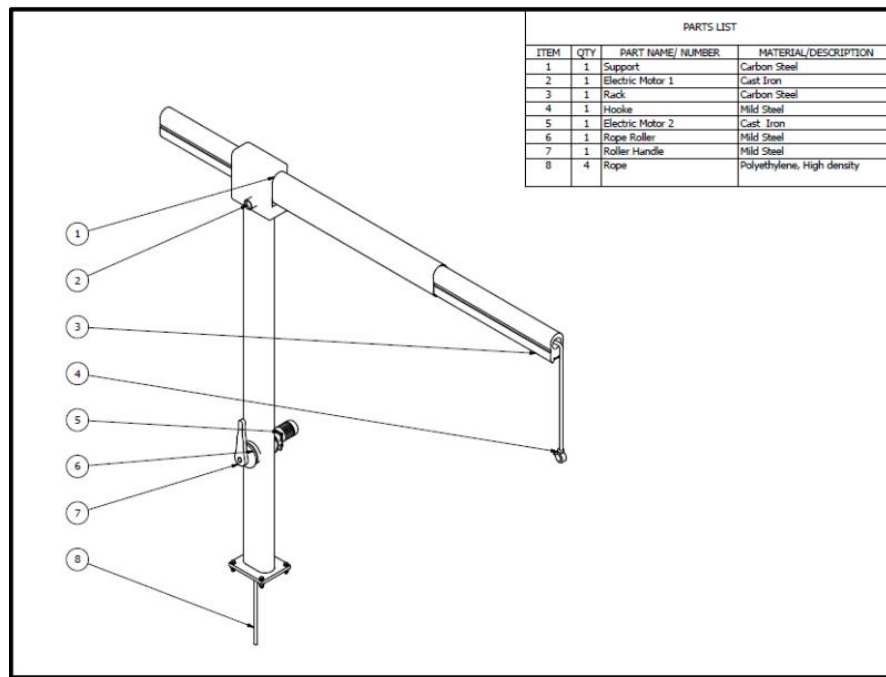

Fig. 2- Parts of the Industrial Tank M-L machine

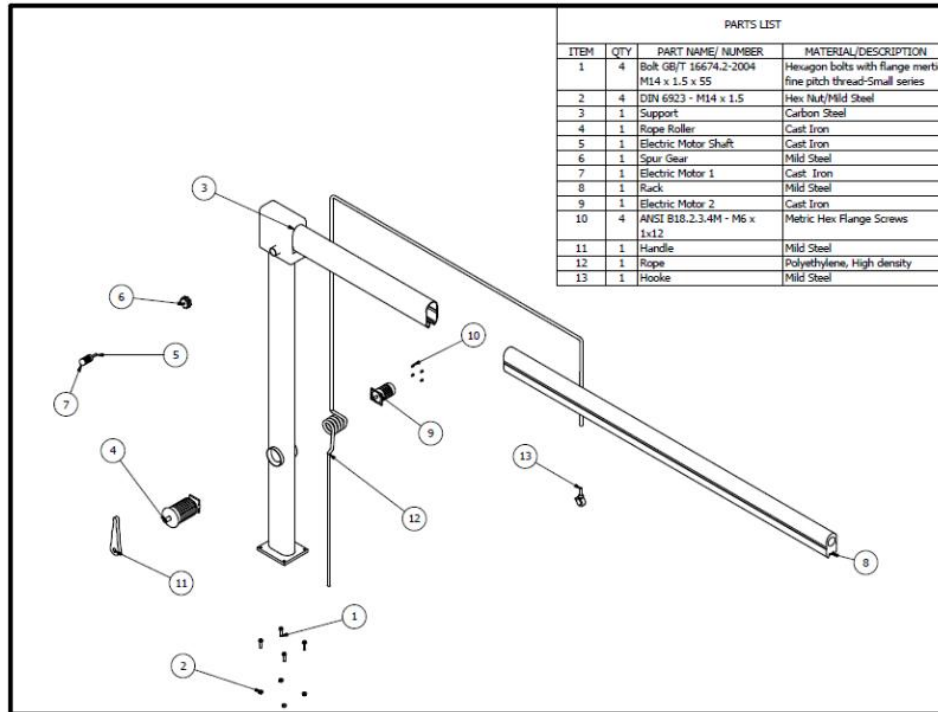

Fig. 3 - Components of Industrial Tank M-L machine

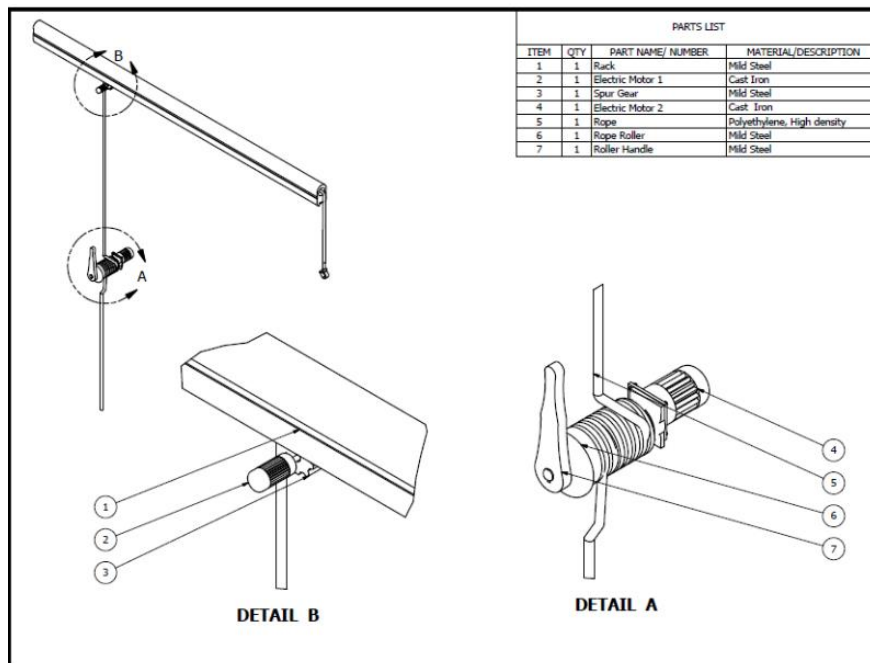

Fig. 4- The gear, rope and roller components of the machine.

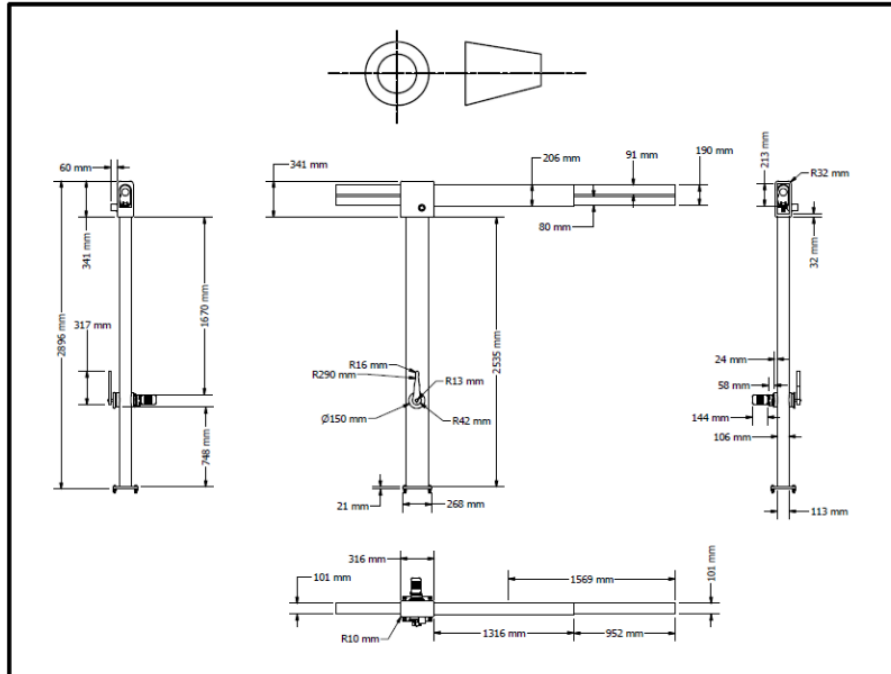

Fig. 5- The 1<sup>st</sup> angle projection of the Industrial Tank M-L machine

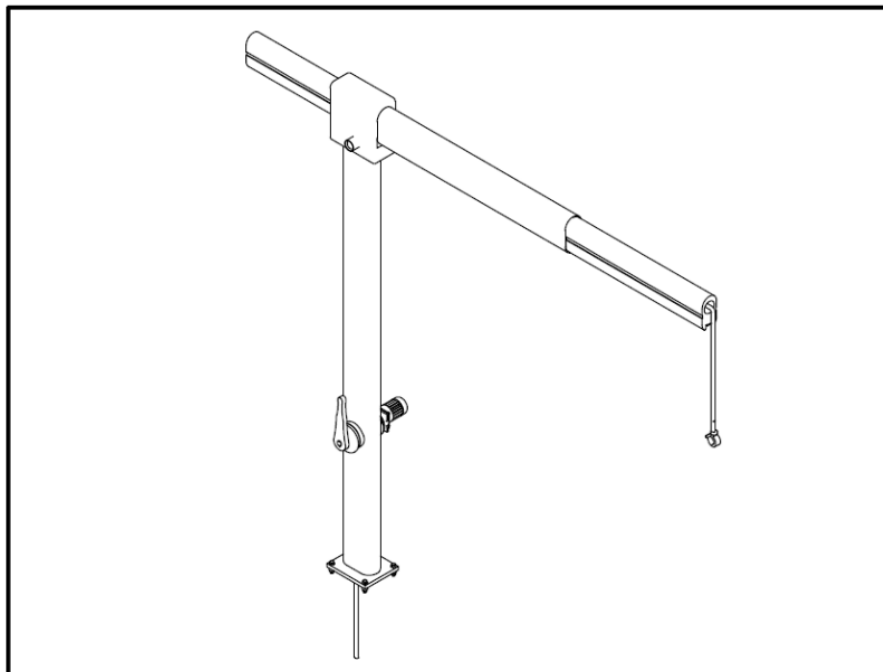

Fig. 6- The Industrial Tank M-L Machine (complete assembly).

### III. DESIGN ANALYSIS AND CALCULATIONS

Two types of tanks usually in use in Industries are the metallic tanks and the plastic types. The plastic tanks seem to be gaining higher currency. It is lighter relatively [4], and is much more portable. It seems to be more durable and costs less in transportation. People feel more comfortable taking substances stored in plastics than in metallic containers because of rusts usually associated with irons. It has also been observed that metals rust and need re-painting

periodically and this of course involves money.

This work focuses on plastic tanks. Specifically, between 1200 litres (220 gals) plastic tanks of weight 31 kg and 37,200 L (8,200 gals) of weight 700 kg [2] on the average. From figure 4, the part labelled A may be adapted and replaced with an electric industrial winch for lifting and lowering heavy loads- a BMW single phase 200v winch from Japan shown in plate 1 [3].



**Plate 1. BMW SINGLE phase100v -200v series (courtesy-MAXPULL.Winch Tokyo Japan**

### IV. RESULTS AND DISCUSSIONS

In a lifting and lowering test run, the (M-L) machine was hoisted 10 m above the ground on a special

structure of a story building. Then a 300 kg tank was lifted into a stand 25 m up and then lowered to the ground level again successfully using the machine with a winch of 400 kg capacity shown in fig. 4.

Table 1. The cost of a unit Industrial M-L Tank

S/n	Component description	Quantity	Cost/unit (N)	Total cost (N)
1	Carbon steel support	1	5000	5000
2	Electric motor	2	2000	4000
3	Roller unit without the rope	1	4000	4000
4	Rope-steel 9 m length, 10 mm thickness	1 length	7000	7000
5	Spur gear	1	1800	1800
6	Rack	1	3000	3000
7	BMW single phase 100v-200v series winch + importation cost	1	14000	14000
8	Miscellaneous- Bolts, hooks, washers, handles, grease, etc	-	5000	5000
	Total cost of machine	-	-	43800 (\$87)

From the machine cost of Table 1, the value is about N43,800. Though this is high, the components are not likely to be replaced until after 2 years.

### ACKNOWLEDGEMENT

The Fabrication and coupling was done at the metal Workshop unit of the Mechanical Engineering Department of Michael Okpara University of Agriculture, Umudike, Abia State, Nigeria.

## REFERENCES

- [1] Plastic Tanks - Plastic Storage Tanks - Bailiff Enterprises  
[http://www.plasticstoragetanks.com/plastic\\_tanks.htm](http://www.plasticstoragetanks.com/plastic_tanks.htm)
- [2] Water Tank Specifications &Dimensions : National Poly Industries  
<http://www.nationalpolyindustries.com.au/info-centre/water-tank-specifications/>
- [3]Maxpull machinery &Engineering Co.,Ltd : A winch  
..www.maxpull.co.jp/ and  
[http://www.maxpull.co.jp/english/index\\_e.htm](http://www.maxpull.co.jp/english/index_e.htm)
- [4] G. C. Dioko,A. Offiong and D.C. Nnadi .*Design of a single phase 3-level, 4-level, 5-level Inverter-Fed Asynchronous. Motor-drive with Diode- clamped Topology*,IJETT.Vol 12.2014.